

# 6

GUIDE FOR  
PRACTITIONERS

CONVERSION OF  
TRADITIONAL  
BUILDINGS  
APPLICATION OF  
THE SCOTTISH  
BUILDING  
STANDARDS  
PART 2  
APPLICATION

TECHNICAL  
CONSERVATION,  
RESEARCH AND  
EDUCATION  
GROUP



6  
GUIDE FOR  
PRACTITIONERS

CONVERSION OF  
TRADITIONAL  
BUILDINGS

APPLICATION OF  
THE SCOTTISH  
BUILDING  
STANDARDS

PART 2  
APPLICATION

Editor  
and Principal Author  
Dennis Urquhart

Published by  
Historic Scotland  
© Crown copyright

ISBN 978 1 904966 47 0

Edinburgh 2007

Commissioned by  
TECHNICAL  
CONSERVATION  
RESEARCH AND  
EDUCATION  
GROUP



GUIDE FOR PRACTITIONERS  
Conversion of Traditional Buildings  
Application of the Building Standards

Editor and Principal Author  
Dennis Urquhart

Contributing Authors\*

Mark Anderson, Stewart Brown, Iain Cram, Jocelyn Cunliffe, Ian Gough, Lyndall Leet,  
Stuart MacPherson, Simon Montgomery, Mark Watson

\* Refer to Acknowledgements for information on the designations of the contributing authors.

ACKNOWLEDGEMENTS

The Editor and authors of this guide recognise that without the support and guidance of a large number of individuals and organisations they would not have been able to undertake a work of this magnitude and complexity. To help focus the structure and content of the guide, a Steering Group was set up by Historic Scotland to provide the necessary support and to represent the interests of the two main stakeholders; namely Historic Scotland (who funded the project) and the Scottish Building Standards Agency. The Steering Group has been instrumental in ensuring that the two main strands of the book, the conservation of historic buildings and the application of the new Building (Scotland) Regulations 2004, have been targeted appropriately towards its principal audience.

Members of the Steering Group included: Ingval Maxwell OBE, Director of TCRE, Historic Scotland; Janet Kleboe, TCRE, Historic Scotland; Simon Montgomery, Inspector of Historic Buildings, Historic Scotland; Jane Robertson, Manager, Historic Scotland Conservation Bureau; Jeff Carter, Assistant Chief Executive, Scottish Building Standards Agency; Dennis Urquhart, Urquhart Consultancy Services and Mark Watson, Historic Scotland.

In addition to the Steering Group, an Advisory Panel met periodically to review and comment on work in progress. The Editor and contributing authors – many of whom were members of the panel – are extremely grateful for the time, effort and invaluable expertise given unstintingly by busy practitioners. In addition to members of the Steering Group, the following individuals also served on the Panel at some time: John Addison, Structural Engineer, Waterman Group; Mark Anderson, Building Control Manager, Midlothian Council; Stewart Brown, Simpson and Brown Architects; Iain Cram, Architect, Bell Ingram Design; Jocelyn Cunliffe, Conservation Architect, Gray, Marshall and Associates; John Duncan, Conservation Officer, Highland Council; Ian Gough, Fire Safety Consultant; Lyndall Leet, Architect (retd), The Leet Rodgers Practice; Stuart MacPherson, Principal, Irons Foulner Consulting Engineers; David Narro, Structural Engineer, David Narro Associates; Elaine Richardson, Midlothian Council; Andrew Wright, Historic Environment Advisory Council for Scotland; Ian Young, Conservation Officer, Midlothian Council.

The Editor would also like to thank the following for their valuable contributions, in the form of detailed drawings, written comments, or in meetings with the Editor or Project Manager: Mike Coull, Grampian Fire and Rescue Service; Richard Fawcett, Historic Scotland; Douglas Forrest, Architect; Paul Harding, Mark Hopton, LDN Architects; Stewart Kidd, British Automatic Sprinkler Association; Hugh Ross, Matheson Mackenzie Ross, Architects; Linda Sheridan, Scottish Building Standards Agency; Benjamin Tindall Architects; Steven Torrie, Deputy Firemaster, Lothian and Borders Fire Brigade and Mark Watson, Historic Scotland, for his rigorous review of Part I.

Special thanks are due to Janet Kleboe for her support during the project, to Ingval Maxwell for wise counsel and leadership of the Steering Group and to Jeff Carter for his advice on the interpretation of the Building Standards.

# CONTENTS

<b>FOREWORD</b>	vii		
<b>APPLICATION OF THE BUILDING STANDARDS</b>	1		
<b>INTRODUCTION</b>	3		
1 The Building Standards	3		
2 Voids in historic fabric	4		
3 Preserving lath and plaster finishes	5		
<b>1. STRUCTURE</b>	9		
1.1 Structure and 1.2 Disproportionate collapse	9		
1.1.1 Type of Standard	9		
1.1.2 Commentary	9		
1.1.3 Issues to be considered	11		
1.1.4 Recommendations to meet the standard	12		
1.1.5 Related standards	20		
<b>2 FIRE</b>	21		
Preface to Fire Standards	21		
2.1 Compartmentation	22		
2.1.1 Type of standard	22		
2.1.2 Commentary	22		
2.1.3 Issues to be considered	23		
2.1.4 Recommendations to meet the standard	24		
2.1.5 Related standards	24		
2.2 Separation	25		
2.2.1 Type of standard	25		
2.2.2 Commentary	25		
2.2.3 Issues to be considered	26		
2.2.4 Recommendations to meet the standard	26		
2.2.5 Related standards	31		
		2.3 Structural protection	31
		2.3.1 Type of standard	31
		2.3.2 Commentary	31
		2.3.3 Issues to be considered	32
		2.3.4 Recommendations to meet the standard	32
		2.3.5 Related standards	33
		2.4 Cavities	33
		2.4.1 Type of standard	33
		2.4.2 Commentary	34
		2.4.3 Issues to be considered	35
		2.4.4 Recommendations to meet the standard	35
		2.4.5 Related standards	36
		2.5 Internal linings	36
		2.5.1 Type of standard	36
		2.5.2 Commentary	36
		2.5.3 Issues to be considered	37
		2.5.4 Recommendations to meet the standard	37
		2.5.5 Related standards	38
		2.9 Escape	38
		2.9.1 Type of standard	38
		2.9.2 Commentary	38
		2.9.3 Issues to be considered	39
		2.9.4 Recommendations to meet the standard	40
		2.9.5 Related standards	42
		2.10 Escape lighting	42
		2.10.1 Type of standard	42
		2.10.2 Commentary	42
		2.10.3 Issues to be considered	42
		2.10.4 Recommendations to meet the standard	43
		2.10.5 Related standards	43
		2.11 Communication	44
		2.11.1 Type of standard	44

2.11.2	Commentary	44	3.2.1	Type of standard	61
2.11.3	Issues to be considered	44	3.2.2	Commentary	62
2.11.4	Recommendations to meet the standard	44	3.2.3	Issues to be considered	62
2.11.5	Related standards	46	3.2.4	Recommendations to meet the standard	62
2.12.	Fire service access	47	3.2.5	Related standards	64
2.12.1	Type of standard	47	3.4	Moisture from the ground	64
2.12.2	Commentary	47	3.4.1	Type of standard	64
2.12.3	Issues to be considered	48	3.4.2	Commentary	64
2.12.4	Recommendations to meet the standard	48	3.4.3	Issues to be considered	66
2.12.5	Related standards	49	3.4.4	Recommendations to meet the standard	66
2.13	Fire service water supply	49	3.4.5	Related standards	70
2.13.1	Type of standard	49	3.6	Surface water drainage	70
2.13.2	Commentary	49	3.6.1	Type of standard	70
2.13.3	Issues to be considered	50	3.6.2	Commentary	71
2.13.4	Recommendations to meet the standard	51	3.6.3	Issues to be considered	71
2.13.5	Related standards	51	3.6.4	Recommendations to meet the standard	72
2.14.	Fire service facilities	52	3.6.5	Related standards	73
2.14.1	Type of standard	52	3.11	Facilities in a dwelling	74
2.14.2	Commentary	52	3.11.1	Type of standard	74
2.14.3	Issues to be considered	54	3.11.2	Commentary	74
2.14.4	Recommendations to meet the standard	54	3.11.3	Issues to be considered	74
2.14.5	Related standards	55	3.11.4	Recommendations to meet the standard	74
2.15	Automatic life safety fire suppression systems	55	3.11.5	Related standards	75
2.15.1	Type of standard	56	3.12	Sanitary facilities	75
2.15.2	Commentary	56	3.12.1	Type of standard	75
2.15.3	Issues to be considered	56	3.12.2	Commentary	75
2.15.4	Recommendations to meet the standard	57	3.12.3	Issues to be considered	76
2.15.5	Related standards	58	3.12.4	Recommendations to meet the standard	76
			3.12.5	Related standards	77
<b>3. ENVIRONMENT</b>		59	3.13	Heating	78
3.1	Site preparation: Harmful and dangerous substances	59	3.13.1	Type of standard	78
3.1.1	Type of Standard	59	3.13.2	Commentary	78
3.1.2	Commentary	59	3.13.3	Issues to be considered	78
3.1.3	Issues to be considered	60	3.13.4	Recommendations to meet the standard	78
3.1.4	Recommendations to meet the standard	60	3.13.5	Related standards	79
3.1.5	Related standards	61	3.14	Ventilation	79
3.2	Site preparation – protection from radon gas	61	3.14.1	Type of standard	79

3.14.2	Commentary	79	<b>4. SAFETY</b>	105
3.14.3	Issues to be considered	80	4.1 Access to buildings	105
3.14.4	Recommendations to meet the standard	80	4.1.1 Type of standard	105
3.14.5	Related standards	85	4.1.2 Commentary	105
3.15	Condensation	86	4.1.3 Issues to be considered	106
3.15.1	Type of standard	86	4.1.4 Recommendations to meet the standard	106
3.15.2	Commentary	86	4.1.5 Related standards	111
3.15.3	Issues to be considered	87	4.2 Access within buildings	112
3.15.4	Recommendations to meet the standard	87	4.2.1 Type of standard	112
3.15.5	Related standards	94	4.2.2 Commentary	112
3.16	Natural lighting	94	4.2.3 Issues to be considered	114
3.16.1	Type of standard	94	4.2.4 Recommendations to meet the standard	114
3.16.2	Commentary	94	4.2.5 Related standards	115
3.16.3	Issues to be considered	95	4.3 Stairs and ramps	116
3.16.4	Recommendations to meet the standard	95	4.3.1 Type of standard	116
3.16.5	Related standards	95	4.3.2 Commentary	116
Preface to Standards 3.18, 3.19 and 3.20: Combustion appliances		96	4.3.3 Issues to be considered	116
3.18	Combustion appliances – protection from products of combustion	96	4.3.4 Recommendations to meet the standard	117
3.18.1	Type of standard	96	4.3.5 Related standards	118
3.18.2	Commentary	96	4.4 Pedestrian protective barriers	119
3.18.3	Issues to be considered	97	4.4.1 Type of standard	119
3.18.4	Recommendations to meet the standard	98	4.4.2 Commentary	119
3.18.5	Related standards	98	4.4.3 Issues to be considered	119
3.19	Combustion appliances – relationship to combustible materials	98	4.4.4 Recommendations to meet the standard	119
3.19.1	Type of standard	98	4.4.5 Related standards	120
3.19.2	Commentary	99	4.8 Danger from accidents	121
3.19.3	Issues to be considered	101	4.8.1 Type of standard	121
3.19.4	Recommendations to meet the standard	101	4.8.2 Commentary	121
3.19.5	Related standards	102	4.8.3 Issues to be considered	122
3.20	Combustion appliances – removal of products of combustion	102	4.8.4 Recommendations to meet the standard	122
3.20.1	Type of standard	102	4.8.5 Related standards	124
3.20.2	Commentary	102	<b>5. NOISE</b>	125
3.20.3	Issues to be considered	103	5.1 Resistance to sound transmission	125
3.20.4	Recommendations to meet the standard	103	5.1.1 Type of standard	125
3.20.5	Related standards	104	5.1.2 Commentary	125
			5.1.3 Issues to be considered	126

5.1.4	Recommendations to meet the standard	127	6.4	Insulation of pipes ducts and vessels	151
5.1.5	Related standards	134	6.4.1	Type of standard	151
			6.4.2	Commentary	152
<b>6. ENERGY</b>		135	6.4.3	Issues to be considered	152
6.1	Policy	135	6.4.4	Recommendations to meet the standard	152
6.1.1	Type of standard	135	6.4.5	Related standards	152
6.1.2	Commentary	135	6.5	Artificial and display lighting	153
6.1.3	Related standards	136	6.5.1	Type of standard	153
6.2	Building envelope insulation	137	6.5.2	Commentary	153
6.2.1	Type of standard	137	6.5.3	Issues to be considered	154
6.2.2	Commentary	137	6.5.4	Recommendations to meet the standard	154
6.2.3	Issues to be considered	139	6.5.5	Related standards	154
6.2.4	Recommendations to meet the standard	141	6.6	Mechanical ventilation and air conditioning	155
6.2.5	Related standards	147	6.6.1	Type of standard	155
6.3	Heating systems	148	6.6.2	Commentary	155
6.3.1	Type of standard	148	6.6.3	Issues to be considered	156
6.3.2	Commentary	148	6.6.4	Recommendations to meet the standard	156
6.3.3	Issues to be considered	149	6.6.5	Related standards	157
6.3.4	Recommendations to meet the standard	150		Draft amended standard 6.10 and new Regulation 17	158
6.3.5	Related standards	151			
			<b>BIBLIOGRAPHY</b>		159

# FOREWORD

The successful conversion of existing buildings is something to be celebrated. When it occurs it may bring a new lease of life to a depressed neighbourhood or the appropriate reuse for a redundant farm steading. From the first pioneer occupation of lofts in Manhattan, or for that matter in Glasgow's Merchant City, converted factories and warehouses spearheaded the renewal of districts. As a catalyst for change, the sensitive conversion of a building can be the first sign of recovery, indicating that an area has turned the corner and is looking forward to a new lease of life yet without rejecting its origins. The reuse of empty mills and warehouses, for example, can be a major element in delivering high-density urban living in a quality environment; a counter to suburban sprawl eating up the countryside. A reused church can continue to give a community meaning even if it is no longer a place of worship. The embodied energy that went into the original construction, using materials that would now be difficult to source make conversions inherently more sustainable than the equivalent built anew. Adaptive reuse is already delivering the sustainability agenda.

This Guide for Practitioners is specifically concerned with the conversion of Scotland's traditionally constructed built heritage. It has been prepared to provide those involved with its design, development and rehabilitation with relevant information on the application of the Building Standards.

The introduction of The Building (Scotland) Regulations 2004 is significant because, together with the supporting Technical Handbooks, they allow judgement to be made on how successfully an existing traditional building can be converted to meet the requirements of the new functional standards. Retaining the historic integrity of the existing built heritage and meeting the standards presents a challenge which frequently requires dialogue to resolve. It is intended that this Guide assists with that dialogue. It does this by outlining the construction, materials and performance of traditional buildings and, by addressing the relevant functional standards that are applicable, illustrates how their successful survival and reuse might be achieved. It also draws attention to the legislation governing traditional buildings.

As the attached formal letter from the Chief Executive of the Scottish Buildings Standards Agency intimates, this Guide legally sits alongside other documents that have been prepared for the purpose of providing practical guidance with respect to the building regulations.

The task of producing the Guide was overseen by a Steering Group consisting of officials from Historic Scotland and the Scottish Building Standards Agency, together with a range of practitioners well versed in the field.

The Managing Editor and lead author, Dennis Urquhart, with support from a number of contributing conservation practitioners, has brought together a wealth of understanding and good practice in this double

volume. Part 1 of the Guide emerges as a platform for raising awareness on how the traditionally constructed built environment embodies the skills, energies and knowledge of our ancestors. Whilst Part 2 reveals how, with appropriate care and consideration, the relevant standards can be accommodated in a way that will permit the effective conversion of a traditional building so that it can be successfully retained for future use.

The presented information is the direct result of discussion and agreement between two government agencies; Historic Scotland and the Scottish Buildings Standards Agency. Historic Scotland has the over-arching responsibility for the protection of the built heritage in Scotland, whilst the Scottish Building Standards Agency has lead responsibility for the legislative functions relating to the building standards system. Both organisations have a remit which inevitably overlaps in places. Consequently there was an inescapable logic for both bodies to consider the production of a joint publication to offer a more integrated and comprehensive approach to practitioners involved in the conversion and adaptation of traditional buildings.

This guidance therefore draws together the responsibilities and legislative viewpoint of both Agencies. Its primary aim is to assist in the finding of sensitive and applicable reuses for a large part of Scotland's built heritage.

The authorship of this ambitious work was a considerable task as questions concerning conservation, relevant legislation and practice constantly needed to be balanced. As a result, bringing together the two seemingly opposing issues of retaining, conserving and repairing the historic environment with the need to address the mechanisms which often have to consider proposed radical changes to that same environment, has been successfully achieved. The result is a unique "text book" which "reinterprets" the Scottish Building Standards.

It is hoped that by being comprehensive, the Guide does not intimidate by its size and range of issues that are covered. It was written to be used as a "reference manual", rather than a technical publication to be read from cover to cover. It aspires to provide confidence to retain older fabric, and help create a sustained future for it, whilst meeting, as far as possible, present day needs.

In conjunction with other published technical material that has emanated from Historic Scotland's Technical Conservation, Research and Education Group over the years, the Guide aims to inform good practice and contribute to the awareness, understanding and appreciation of Scotland's traditionally constructed building stock and its adaptation to new uses.

**Ingval Maxwell, OBE**  
**Director TCRE**  
**Edinburgh**

12 March 2007



Chief Executives – Scottish Local Authorities

Copy to: Local Authority Building Standards Managers



Paul.Stollard@sbsa.gsi.gov.uk  
Telephone: 01506 600400  
Fax: 01506 600401

Our ref: QTO 2/4

12 March 2007

Dear Chief Executive

**BUILDING (SCOTLAND) ACT 2003 – NOTICE UNDER SECTION 4(2) AND 4(4)  
RELATING TO GUIDANCE DOCUMENTS**

Under the provisions of Section 4(1) of the Building (Scotland) Act 2003 (the Act), which came into force on 1 May 2005, Scottish Ministers may issue guidance documents for the purpose of providing practical guidance with respect to the requirements of any provision of building regulations and may issue revisions of the whole or any part of any guidance document.

Guidance documents issued under Section 4(1) of the Act take effect in accordance with a notice issued by Scottish Ministers under Section 4(2) of the Act. This letter, issued on behalf of Scottish Ministers, constitutes such a notice.

From 1 May 2007 the following document is added to the guidance documents for purpose of building regulations:

*The Guide for Practitioners – Conversion of Traditional Buildings*, issued by Historic Scotland.

The guidance documents are issued with respect to the provision of Regulations 1 to 15 of The Building (Scotland) Regulations 2004.

As provided for by Section 4(3) and 4(4) of the Act, this document will cease to have effect in relation to building warrant applications when notice is given by Scottish Ministers.

Yours sincerely

**DR PAUL STOLLARD**  
Chief Executive

---

Scottish Building Standards Agency, Denholm House, Almondvale Business Park, Livingston EH54 6GA.  
web: [www.sbsa.gov.uk](http://www.sbsa.gov.uk) tel: 01506 600 400

PART II:  
APPLICATION OF THE  
BUILDING STANDARDS



# INTRODUCTION

## 1 The Building Standards

Part II deals with the application of the Building Standards to the conversion of historic buildings. It is not intended to address every standard, but will offer advice on how best to satisfy those functional standards that are most likely to have the greatest potential impact on the character of historic buildings. However, it must be borne in mind that each historic building is unique, or will at least contain unique features, which means that the use of model solutions to meet the requirements of the standards must be treated with caution. Each situation must be carefully assessed so that the most appropriate solution, which meets the standard without compromising the historic character of the building, is achieved.

**The advice provided in this section is based on best practice for the situations described. It is designed to meet the requirements of the Building Standards and provide the greatest protection to the character of historic buildings. The examples of solutions offered have been approved by the Scottish Building Standards Agency and Historic Scotland as generic examples of how to satisfy the relevant functional standards. However, the advice provided is applicable to only the described situations: they are not deemed to satisfy specifications for general application. Because this guidance can only be of a general nature and, where the construction or other features of the building do not accord with the descriptions in the examples; the construction, materials and elements of the building must be thoroughly assessed before any of the recommendations are implemented. In some situations appropriate testing may be required.**

**From May 2007 there will be changes to the wording of a number of the Building Standards. The detailed changes have not been available for incorporation into this guide. However, these are unlikely to have a significant effect on the arguments and advice set out in the Guide. Readers should refer to the notes included within the individual standards that are affected by these changes.**

Within Regulation 12, the application of the standards to the conversion of historic buildings recognises that achieving the full standard will not be possible in many situations. It is for this reason that those standards having a direct impact on the health and safety of occupiers and users of buildings are differentiated from those that do not. Box 1 reproduces Schedule 6 of Regulation 12 and identifies application of the various standards.

### Box 1. Regulation 0.12 and Schedule 6

**Regulation 0.12. *Conversion shall be carried out so that the building as converted complies with the applicable requirements of Schedule 6.***

#### *Schedule 6*

Every conversion, to which these regulations apply, shall meet the requirements of the following standards in schedule 5:

- standards 2.1, 2.3, 2.5, 2.9, 2.10, 2.11, 2.13, 2.14, 2.15, in section 2, fire safety;
- standards 3.5, 3.6, 3.7, 3.8, 3.9, 3.11, 3.12, 3.13, 3.14, 3.17, 3.18, 3.20, 3.21, 3.22, 3.23, 3.24, 3.25, 3.26, in section 3, environment;
- standards 4.5, 4.6, 4.7, 4.9, 4.11, 4.12, in section 4, safety and
- the standards in section 5, noise;
- standards 6.1, 6.7, 6.8, in section 6 energy.

Every *conversion*, to which these regulations apply, shall be improved to as close to the requirement of the following standards in schedule 5 as is *reasonably practicable*, and in no case be worse than before the *conversion*:

- the standards in section 1, structure;
- standards 2.2, 2.4, 2.6, 2.7, 2.8, 2.12, in section 2, fire safety;
- standards 3.1, 3.2, 3.3, 3.4, 3.10, 3.15, 3.16, 3.19, in section 3, environment;
- standards 4.1, 4.2, 4.3, 4.4, 4.8, 4.10, in section 4, safety; and
- standards 6.2, 6.3, 6.4, 6.5, 6.6, in section 6, energy.

Table 3 is a summary of the standards and identifies those that are addressed in Part II and those that are not. Only those standards most likely to have an impact on the fabric and character of historic buildings have been included for detailed advice.

The Building (Scotland) Act 2003 gives specific protection to historic buildings and the classification of the building should influence the extent to which improvements to meet the relevant standards are required. This guide provides advice applicable more widely than defined in the Act, to cover the range of traditional buildings defined in Part I, Section 1.2 of this guide. The definition of a historic building is necessary because the building regulations now recognise that existing buildings being converted cannot always meet the full requirements.

While the following sections are set out to reflect the order and content of the individual standards, there will be many instances when the needs of one standard will impact upon another. The standards may also influence the way in which the fabric of the building reacts to the changes imposed upon it. Sometimes an attempt to satisfy a standard may cause a change in the fabric condition that is detrimental to the building. For example, sealing off ventilation pathways within the construction to satisfy the needs of improved building envelope insulation, fire safety and noise insulation can raise humidity levels in hidden voids to dangerous levels. Consequently, it is important to have a sound understanding of how a traditional building functions, so that any changes imposed on the building are fully understood. Each standard should not be addressed in isolation, and the solution or solutions adopted must be assessed to determine their impact on the performance of the building as a whole. A holistic approach to the application of the building standards to traditional buildings is therefore essential.

In Schedule 6, two classifications of standards are established for conversions, those that require every conversion to meet the requirements of the standards (*essential standards* in Table 3); and those that shall be improved to as close to the standard as reasonably practicable (*reasonably practicable standards* in Table 3).

In the case of essential standards, where these apply to a historic building, no relaxation of the standard is available. However, the flexibility inherent in the functional nature of the standards does mean that it may be possible to achieve the function by alternative means. For example, the use of active fire-safety measures may allow for apparent deficiencies in other areas. Nevertheless, there may arise situations where it will be impossible to meet the standard without serious disruption to important historic features. A case in point could be where the need to upgrade the fire and sound insulating properties of a floor to the standard of a separating floor is not achievable without unacceptable disruption to, or destruction of, ceiling and floor finishes. Where the cultural value of these elements is such that their loss is unacceptable, the conversion of the building into separate apartments arranged above each other will not be a viable form of development for the building. A vertical division of the building, rather than a horizontal one, may be a better option.

For *reasonably practicable standards*, the protection of the historic character of the building is given much greater emphasis in the way in which the standard is addressed. While the requirement is to make every effort to achieve the relevant standard, the standard actually achieved may have to be a compromise in order to assure protection of the historic building. However, a 'do nothing' approach will not be acceptable.

In the application of the standards, significant changes from the previous regulations must be recognised. The former '*deemed to satisfy*' standards were accepted as complying with the regulations and alternative solutions could be achieved only by means of a relaxation from the prescribed standard. The new functional standards permit alternative means of meeting a standard, and the system of obtaining a relaxation from the local authority has therefore been disbanded (refer to Part I for further information). The conversion of a historic building sets challenges to designers, certifiers of design and verifiers because each situation is unique. It will be essential to understand how the building performs in use and to conduct a full appraisal of the relevant features of the building, with testing where appropriate, to ensure compliance with the standard. It is likely to be beneficial for the designer and verifier to discuss proposed solutions for potentially contentious issues at an early stage in the process.

## 2 Voids in historic fabric

There are many instances in the application of the standards when, in satisfying their requirements, the natural ability of the historic fabric to 'breathe' is either eliminated or reduced. This can occur in the following circumstances:

- a) The upgrading of thermal insulation to existing external walls by lining the walls with insulation and vapour barriers seals off air leakage into the void between the lining and the wall, creating stagnant conditions.
- b) The introduction of separating floors, where the junction between the wall and floor is sealed to prevent fire spread and flanking sound transmission, which, in turn, prevents the through ventilation of the void behind

the existing historic lath and plaster wall finish.

- c) Sealing off the void behind the lath and plaster at its junction with the roof, usually by installing insulation in the roof that is continued into the eaves.
- d) Sealing up gaps in construction to reduce air leakage and improve the thermal performance of the building.

The most difficult and contentious problem is, nevertheless, how best to provide ventilation to voids when floor and wall junctions require to be sealed to prevent fire spread and sound transmission. Unfortunately, it is often the case that the need for historic fabric to breathe is either forgotten or ignored in the design of a conversion. Providing such ventilation should be specifically included in the design. Possible outline solutions to achieving ventilation of hidden voids are shown in Illus .1 (see also Illus 3.15.5 in Section 3.15, Condensation).

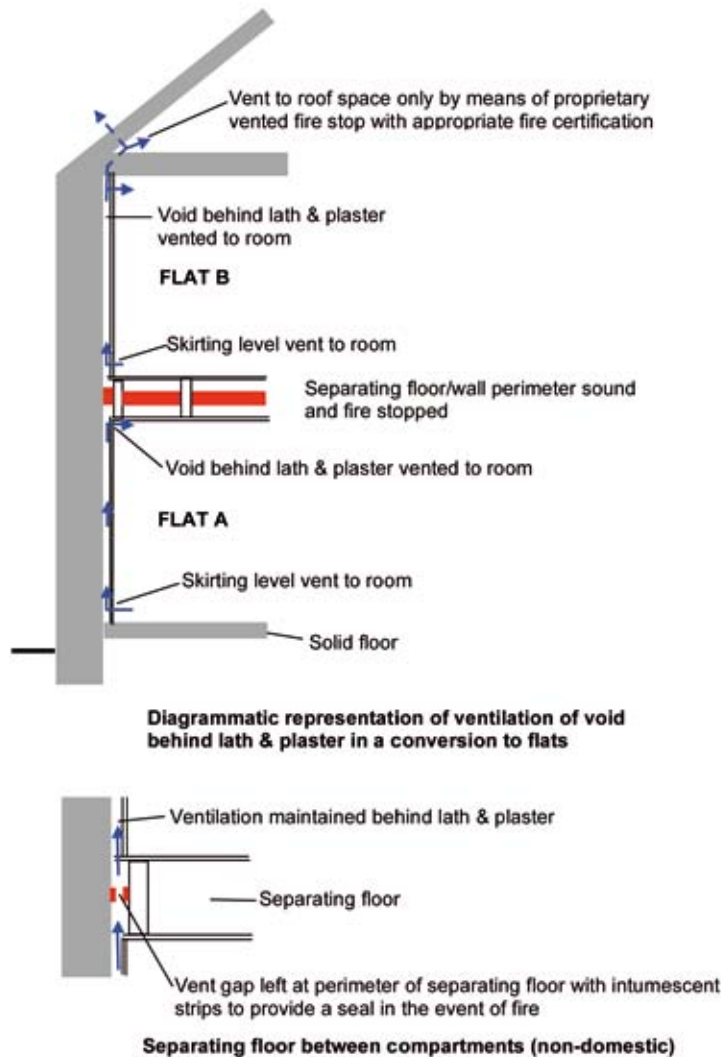

Illus 1 Diagrammatic representation of ventilation of void behind lath and plaster or other finishes by vents at floor and ceiling level.

### 3 Preserving lath and plaster finishes

In the conversion of a historic building the requirement to improve the thermal performance of the building may encourage the removal of existing historic finishes, such as traditional lath and plaster and timber panelling, to

allow for the installation of thermally-efficient insulation to external walls. Undoubtedly, applying insulation in this way will greatly improve the thermal performance of the building. However, a balance must be struck between improved thermal performance and preservation of historic fabric – of which traditional lath and plaster (usually lime plaster) and timber panelling are key elements. ***It is therefore recommended that, wherever possible, traditional lath and plaster and other historic finishes should be retained and thermal efficiency improvements to the building achieved by other means.***

The presumption that lath and plaster and other historic finishes will be preserved is reflected in many of the recommended means of addressing the various standards provided in the following pages. Where lath and plaster is in such poor condition that it would have to be removed and replaced, the requirement to improve the thermal insulation of the envelope should be implemented.

Table 3. Summary assessment of the potential impact of the building standards on historic buildings. Note: standards shown in italics are not included within the advice on the application of the building standards.

Essential Standards				Reasonably Practicable Standards					
No.	Standard	Potential Impact †			No.	Standard	Potential Impact		
		H	M	L			H	M	L
1. Structure									
					1.1	Structure	✓		
					1.2	Disproportionate collapse	✓		
2. Fire safety									
2.1	Compartmentation	✓			2.2	Separation	✓		
2.3	Structural protection	✓			2.4	Cavities	✓		
2.5	Internal linings	✓			2.6	<i>Spread to neighbouring buildings</i>			X
2.9	Means of escape	✓			2.7	<i>Spread on external walls</i>			X
2.10	Escape lighting		✓		2.8	<i>Spread from neighbouring buildings</i>			X
2.11	Communication		✓		2.12	Fire service access		✓	
2.13	Fire service water supply (Non-dwellings only)		✓						
2.14	Fire service facilities		✓						
2.15	Automatic life safety fire suppression systems	✓							
3. Environment									
3.5	<i>Existing drains</i>			X	3.1	Site preparation - harmful substances		✓	
3.6	Surface water drainage		✓		3.2	Site preparation - protection from radon		✓	
3.7	<i>Wastewater drainage</i>			X	3.3	<i>Flooding &amp; ground water</i>			X
3.8	<i>Private wastewater treatment plants</i>			X	3.4	Moisture from the ground	✓		
3.11	Apartments (Dwellings only)	✓			3.10	<i>Precipitation</i>			X
3.12	Sanitary facilities	✓			3.15	Condensation (Dwellings only)	✓		
3.13	Heating (Dwellings only)		✓		3.16	Natural lighting (Dwellings only)	✓		

† Potential impact: H – high, M – moderate, L – low

3.14	Ventilation	✓			3.19	Combustion appliances – combustible materials		✓	
3.17	<i>Combustion appliances - Safe operation</i>			X					
3.18	Combustion appliances – Protection from products of combustion		✓						
3.20	Combustion appliances – Removal of products of combustion		✓						
3.23, 3.24	<i>Oil storage</i>			X					
3.25	<i>Solid waste storage (Dwellings only)</i>			X					
3.26	<i>Dungsteads &amp; farm effluents</i>			X					
<b>4. Safety</b>									
4.5	<i>Electrical safety</i>			X	4.1	Access to buildings	✓		
4.6	<i>Electrical fixtures (Dwellings only)</i>			X	4.2	Access within buildings	✓		
4.7	<i>Aids to communication (Non-domestic)</i>			X	4.3	Stairs and ramps	✓		
4.9	<i>Danger from heat</i>			X	4.4	Pedestrian protective barriers	✓		
4.11	<i>Liquified petroleum gas</i>			X	4.8	Danger from accidents	✓		
4.12	<i>Vehicle protective barriers</i>			X	4.10	<i>Fixed seating (Non-domestic)</i>		X	
<b>5. Noise</b>									
5.1	Resisting sound transmission	✓							
<b>6. Energy</b>									
6.1	Policy	✓			6.2	Building insulation envelope	✓		
6.7	<i>Commissioning building services</i>			X	6.3	Heating system		✓	
6.8	<i>Written information</i>			X	6.4	Insulation of pipes, ducts and vessels	✓		
					6.5	Artificial display lighting (Non-domestic)		✓	
					6.6	Mechanical ventilation & air conditioning (Non-domestic)	✓		

Note: From May 2007, there will be changes to the wording of standards 1.1, 3.11 to 3.13, 3.23 and 3.24, 4.1 and 4.2, 4.6, 4.8 and all standards in Section 6. A note on the effect of the likely changes is included with the commentary on each standard covered in this guide.





# 1. STRUCTURE

## 1.1 Structure and 1.2 Disproportionate collapse

### Standard 1.1

Every *building* must be designed and *constructed* in such a way that the loadings that are liable to act on it will not lead to:

- a) the collapse of the whole or part of the *building*; or
- b) deformations which would make the *building* unfit for its intended use, unsafe, or cause damage to other parts of the *building* or to fittings or to installed equipment.

### Standard 1.2

Every *building* must be designed and *constructed* in such a way that in the event of damage occurring to any part of the structure of the *building*, the extent of any resultant collapse will not be disproportionate to the original cause.

### 1.1.1 Type of Standard

#### *Reasonably practicable standard (Standard 1.1 and Standard 1.2)*

Every *conversion*, to which these regulations apply, must be improved to as close to the requirement of the standard as is *reasonably practicable*, and in no case be worse than before the *conversion*.

### 1.1.2 Commentary

While the Structure standards are covered by the two separate standards shown above (Standard 1.1 and Standard 1.2), the nature of historic buildings is such that it is not considered practical to address the relevant issues within two separate sets of advice.

When dealing with the structure of a historic building, whether exposed or hidden, it is important to remember that all of the internal structure contributes to a listed building's special character and is historically valuable. In the case of listed buildings, listed building consent may be needed for structural alterations, and may also be required for 'opening-up' for inspection prior to the design of the conversion.

While the materials and construction techniques used for historic buildings will be generally similar between buildings – comprising mainly masonry walls, timber upper floors and timber pitched or flat roof structures – each building will present a unique structural challenge when undergoing conversion. Although the structure of traditional buildings will probably be formed from apparently 'simple' materials, they may not be constructed in a simple manner. In addition, traditional methods of construction tended to vary from region to region and according to the period of construction. Historic buildings are also likely to have been altered, extended and repaired at various times over the lifespan, thus complicating the analysis of the structural behaviour of the building.

Unlike new build, the effects of time may have caused deterioration in the structural performance of walls and timber. This is especially true when dealing with water penetration or the effects of material degradation. Also, when the effects of deterioration are combined with a structure where the structural forces were not fully understood when it was built, for example tying-in of floors and walls, the actual stability of the structure may be compromised. This may not be obvious from a superficial and uninformed inspection of the building. No assumptions regarding the construction and structural stability of a building should therefore be made without a careful study of the structure and materials. Only qualified specialists who are properly knowledgeable and experienced in historic building structures should carry out any assessment of the structure of a historic building. Any alteration, conversion or extension to a historic building will affect the original structure, and great care must be taken to ensure that all possible information on the existing structure and materials is obtained prior to the design of the conversion. The

impact of the building works should be carefully considered at the design stage and every effort made to mitigate the effects.

A further complication when dealing with historic structures is that the load bearing capabilities of the various structural elements within the building may not be easily determined using current British Standards structural codes of practice. This can lead to uncertainty regarding structural performance and, in turn, to a 'belt and braces' approach to design that may be unwarranted and cause unnecessary damage to historic fabric. When in sound condition many historic structures have, intrinsically, a high residual factor of safety that is difficult to compute using normal design procedures. They may be capable of sustaining additional loads without adverse effects.

While repair of structural defects will, when necessary, form part of the works of conversion, it is not the intention of this commentary to try to provide advice on all possible structural defects and associated remedial action. Rather, the advice will concentrate on some of the structural issues that may arise as a consequence of changing conditions resulting from the conversion of a historic building.

In a conversion, one of the key structural issues that is most likely to occur is an increase or change in loading conditions due to a change of use. The fact that a building is historic does not remove the overriding requirement for public safety. However, this does not mean that the conversion should be carried out in a manner that will diminish the value and appearance of the building.

Typical changes that may affect the structural system as a result of conversion, some of which may result in disproportionate collapse, include the following (a fuller list is contained in section 1.1.3):

- increased floor loads due to changes in occupation,
- inadequate tying-in of floors and roofs to walls which may become more critical with increased loads,
- increased loads on escape routes, including stairs and landings.

While all of the above issues are important, it is the increase in design floor loads as a result of change of use that is most commonly encountered. Few historic buildings, apart from those built for industrial purposes such as mills and warehouses, are capable of carrying large imposed floor loadings. As a result, it has often been the case that quite drastic structural strengthening has been designed into historic building conversions to accommodate design floor loads for a change of use to offices. The rationale for this is that office space needs to have sufficient flexibility in the way it is used and that it is therefore necessary to ensure that no part of the floor can be accidentally overloaded with the resultant risk of excessive deflections or possible collapse. The design floor loads specified in the British Standard (BS 6399 Part 1: 1996), suggests design loads of 2.5kN/m<sup>2</sup> for offices for general use, 3.5kN/m<sup>2</sup> for spaces with fixed computers, and 5.0kN/m<sup>2</sup> for storage space. Corridors and access stairs should be designed for 3.0kN/m<sup>2</sup> or 4.0kN/m<sup>2</sup>. However, it should never be necessary to apply such high loadings in historic buildings that are to be used as offices. The reasons for this are reviewed in the English Heritage publication (1996) '*Office and floor loading in historic buildings*'. Upgrading a historic building to carry unrealistically high superimposed loads can result in major structural intervention, sometimes resulting in complete removal of the internal floors and partitions, which may not be justified by the perceived design loads.

Existing historic stairs are another contentious structural issue. The structural capacity of many historic stairs, some constructed of stone steps and landings, ostensibly 'cantilevered' out from supporting walls, cannot be confirmed by normal design calculation but are likely to be well capable of withstanding the superimposed loads liable to be encountered in a change of use conversion. The vast majority of these stairs continue to be in use, many more than 200 years old, and show no signs of structural instability. They have therefore stood the test of time.

From May 2007, draft amended Standard 1.1 is:

*Every building must be designed and constructed in such a way that the loadings that are liable to act on it, taking into account the nature of the ground, will not lead to:*

- a) the collapse of the whole or part of the building; or*
- b) deformations which would make the building unfit for its intended use, unsafe, or cause damage to other parts of the building or to fittings or to installed equipment; or*
- c) impairment of the stability of any part of another building.*

These amendments do not alter the guidance offered on this standard.

**1.1.3 Issues to be considered**

Issue	Risks to historic/traditional buildings
1. Poor knowledge and understanding of traditional building materials and structures	<ul style="list-style-type: none"> <li>• Inappropriate structural intervention, which may be unnecessary and adversely affect historic character. Cracking may also result due to lack of understanding of load paths in traditional materials.</li> </ul>
2. Increased floor loading	<ul style="list-style-type: none"> <li>• Excessive deflections causing damage to historic ceilings or collapse of the floor.</li> <li>• Insensitive floor strengthening can be destructive to fabric and architectural value of spaces.</li> <li>• Transfer of increased floor loads to weakened masonry walls may cause detachment of inner and outer faces of walls with a rubble core.</li> <li>• Introduction of new supporting columns and beams could be damaging to historic spaces.</li> <li>• Poorly executed previous repairs to floor joists and beams may not withstand additional loading.</li> <li>• Introduction of strengthening beams and their support can be very destructive to historic fabric.</li> </ul>
3. Historic stairs within escape routes	<ul style="list-style-type: none"> <li>• Strengthening stairs, especially cantilever stairs, can destroy their character. Load tests can be adopted to confirm loading capacity.</li> </ul>
4. Tying-in walls and floors	<ul style="list-style-type: none"> <li>• When floors require to be structurally attached to walls, the process can be destructive to historic finishes.</li> </ul>
5. Improving stability of rubble-cored walls	<ul style="list-style-type: none"> <li>• The use of exposed plates, as part of the stabilising process, may be aesthetically unacceptable for a converted building.</li> <li>• Gravity grouting of voids in the wall may cause further damage if poorly supervised or if too strong grouting mortar is used.</li> </ul>
6. Removal of internal walls	<ul style="list-style-type: none"> <li>• The load paths and load transfer mechanisms in historic buildings are often difficult to determine: removal of apparently non-structural walls can cause structural distress.</li> </ul>
7. Temporary removal of floor boards	<ul style="list-style-type: none"> <li>• In some situations the floorboards act as a horizontal bracing membrane and the complete removal of the boards (even temporarily) may cause movement in walls or buckling of the floor.</li> </ul>
8. New openings in floors	<ul style="list-style-type: none"> <li>• Forming a new opening in a timber floor may change loading conditions on other parts of the floor and on supporting walls and beams.</li> </ul>
9. New or altered door and window openings	<ul style="list-style-type: none"> <li>• Any new or altered penetrations in walls will change the pattern of load distribution in the wall, and new lintels or cills can affect wall stability if they are not properly built in.</li> <li>• Poorly built-in replacement safe lintels may promote settlement of the wall above.</li> </ul>
10. Internal stud partitions	<ul style="list-style-type: none"> <li>• Many historic stud partitions contain diagonal bracing; the partition then acts as a truss to carry both vertical and lateral loads. Poorly designed openings into the partition (even those without diagonal bracing) may affect the stability of the building.</li> </ul>
11. Slender internal load-bearing masonry walls	<ul style="list-style-type: none"> <li>• Historic buildings may have half-brick thick load bearing partitions associated with high floor to ceiling heights. The walls may extend the full height of the building without being effectively tied to floors – any increased loads may result in buckling or collapse of the wall. Old lime mortar joints may also have lost strength over time.</li> </ul>
12. New services installations	<ul style="list-style-type: none"> <li>• New services, and plant and water storage facilities will increase loads on roof structures, floors and walls. Existing timber joists may be notched to suit new services, which may lead to local failures.</li> </ul>
13. Use of inappropriate materials	<ul style="list-style-type: none"> <li>• The use of hard, dense and shrinkable cement mortar and concrete in traditional structures may change the moisture distribution pattern and promote shrinkage stresses within the existing materials.</li> </ul>
14. Shallow foundations	<ul style="list-style-type: none"> <li>• Historic walls often have shallow foundations with very little cover, built from large stones placed on the ground. Uncontrolled excavations for new drainage, services and landscaping etc. can undermine or reduce the stability of such foundations.</li> </ul>
15. Chimney flues	<ul style="list-style-type: none"> <li>• New openings in historic walls may coincide with an old flue.</li> </ul>

### 1.1.4 Recommendations to meet the standard

For the reasons outlined above, dealing with the structural design elements of the conversion of a historic building presents challenges that are not present in new build. This means that it is difficult to provide recommendations that may be regarded as generic solutions because of the unique nature of the structural problems presented. This section will therefore restrict advice to a few of the more common situations encountered in practice. However, caution is required in their interpretation and application to actual buildings.

#### *Structural surveys and load tests*

Standard 1.1 Structure and Standard 1.2 Disproportionate collapse, are two standards for which the system of approved certifiers of design will be employed.

**For all but the most basic of buildings, and before any design work is put in hand, it is essential that a full structural survey and assessment of the building is carried out by an engineer suitably qualified and experienced in working with historic or traditional buildings.** It is commonly the case that, because of the complexity of the interaction of materials, components and possibly alterations to the structure over past years, structural analysis using BS Codes of Practice will not provide the necessary reassurances regarding the stability of the structure. For this reason, it is often necessary to employ load tests on existing elements to confirm the structural capabilities of the structure or its elements. Load tests are typically carried out on floors, especially timber upper floors, and staircases where normal design calculation is inappropriate.

#### *Improving the stability of rubble cored walls*

Rubble cored walls, whether rendered or faced with ashlar stone, are vulnerable to the effects of moisture and applied loads, which may have increased over the life of the building. The possible effect of these actions is for the outer and inner elements of the wall to no longer act in an homogeneous manner and for them to start to separate, especially when they are inadequately tied to intermediate floors as frequently is the case (Illus 1.1.1).

There are a number of techniques that may be used to increase the stability of such walls, either singly or in combination. For example, gravity grouting can be applied to the core of the wall to fill the voids and to tie the wall together. This is a specialised technique, which for historic walls requires careful design of the grouting mortar and close control of the injection process. However, there is a risk that the wall could be further damaged by this process if it is carried out and supervised by persons lacking the necessary expertise.

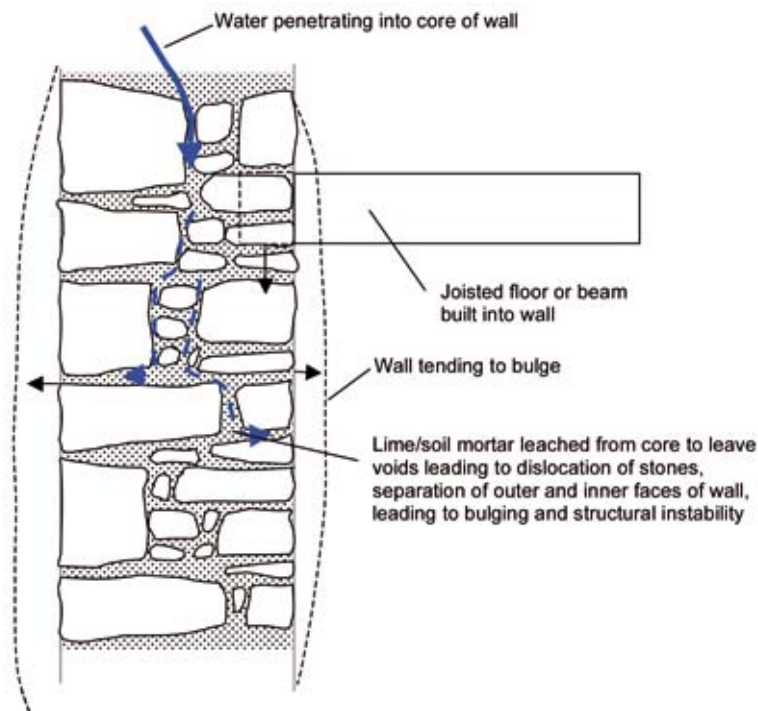

*Illus 1.1.1 Potential structural instability of historic rubble wall due to creation of voids in the core.*

Tying-in, or stitching, of the two faces of a rubble cored wall can also be achieved by the use of anchor rods grouted into the wall (Illus 1.1.2). These rods may be positioned at centres appropriate to the condition of the wall and can be used to tie in flank walls, which are frequently only butt-jointed to perimeter walls.

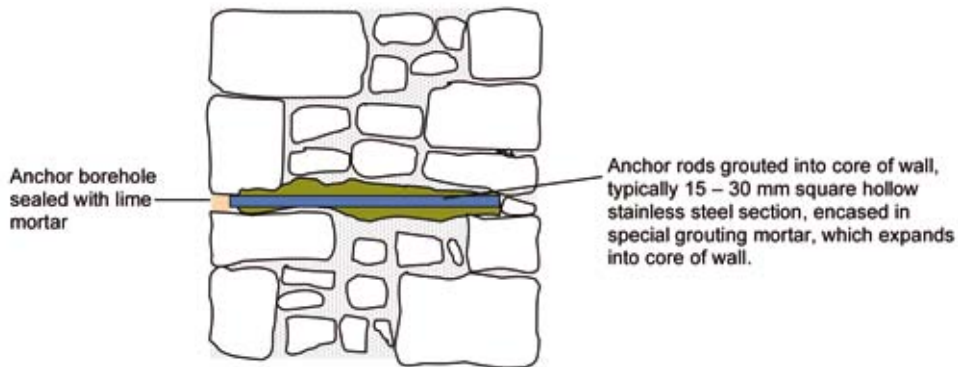

*Illus 1.1.2 Tying-in (stitching) of inner and outer faces of a rubble wall using grouted anchors.*

It is often the case that timber upper floors are not securely tied into supporting walls and thus provide little lateral stability to the wall. During a conversion there is therefore frequently a need to improve the structural connection between walls and floors. The traditional method of bracing a wall by this means is to anchor the floor to a plate on the outside face of the wall, as shown in Illus 1.1.3. However, while this is an acceptable structural solution, the visible nature of plates on external faces can detract from the historic character of the wall. Perhaps more significantly, in the case of a conversion development they may raise questions about the stability of the structure in the minds of clients. An alternative floor to wall tying-in arrangement, which avoids the use of exposed plates, is shown in Illus 1.1.4.

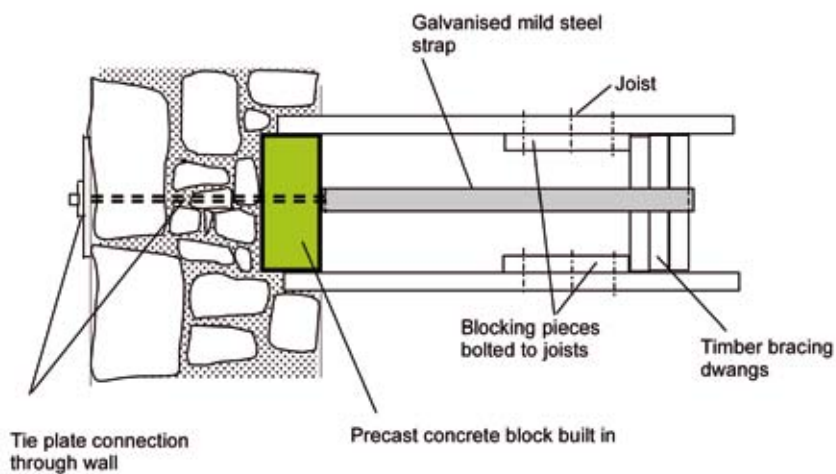

*Illus 1.1.3 Plan view of wall bracing arrangement using a tie plate connection through the wall.*

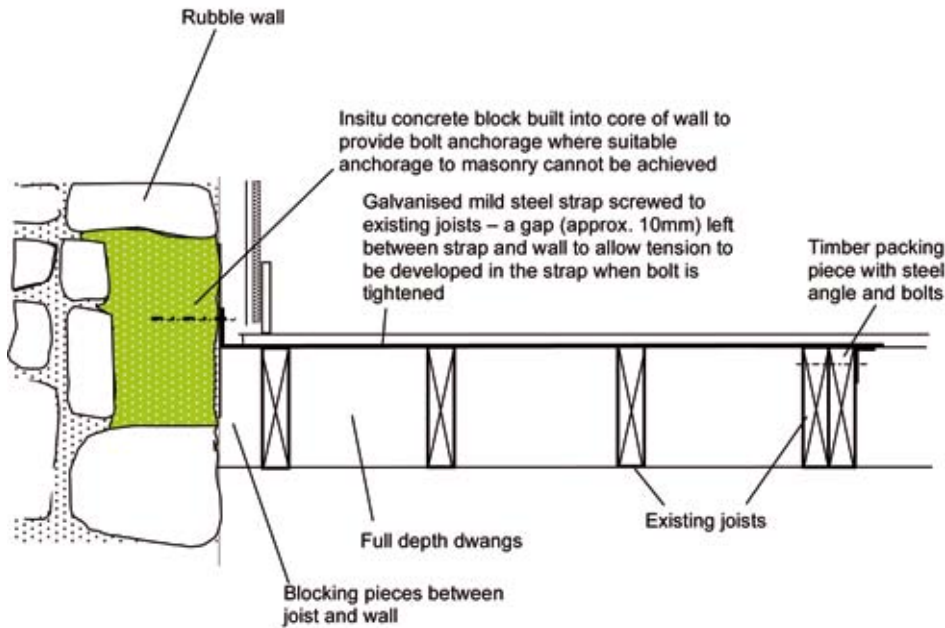

**Floor/wall tying to improve structural stability**

*Note: reinstatement of floor at junction with wall will be required and damage to lath and plaster may be incurred, which will require repair.*

*Illus 1.1.4 Sectional view of strap fixing of floor to wall to provide lateral support to wall.*

*Strengthening timber floors*

The need to increase the strength of timber upper floors is one of the most common structural problems encountered in a historic building conversion. All too often an early design decision is made to replace such floors with new concrete floors, particularly where the building is being converted to commercial or office use. Because such a decision will inevitably mean that much of the character of the interior of the building will be destroyed, there is a strong case for reassessing the design to try to mitigate the distribution of the heaviest loading conditions by, for example, placing storage spaces on ground floors or within basements. Load testing of the floor may show that such drastic action is unnecessary and that with appropriate strengthening the existing floor may be adapted to support increased loads without drastic loss of historic fabric.

Because of the dampness of many historic walls, decay of built-in timber joists and beams is a common occurrence, usually as a result of inadequate maintenance. The structural resolution of decayed ends of joists and beams is relatively straightforward and, when carefully designed and constructed, need not result in too much damage to historic fabric. A possible solution to this problem is shown in Illus 1.1.5. Alternatively, where the existing joist pocket in the wall is sufficiently large, the ends of the splice plates may be set into the pocket and supported on a concrete pad. Because a wall will

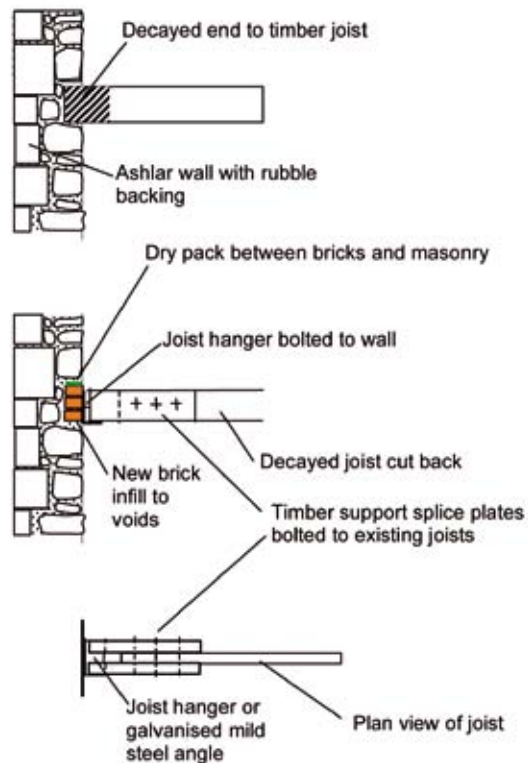

**Note:** Where a number of joist ends have to be repaired, a timber runner should be bolted to the wall to support the new joist hangers carrying the joists

*Illus 1.1.5 Repair of and support for ends of decayed joists.*

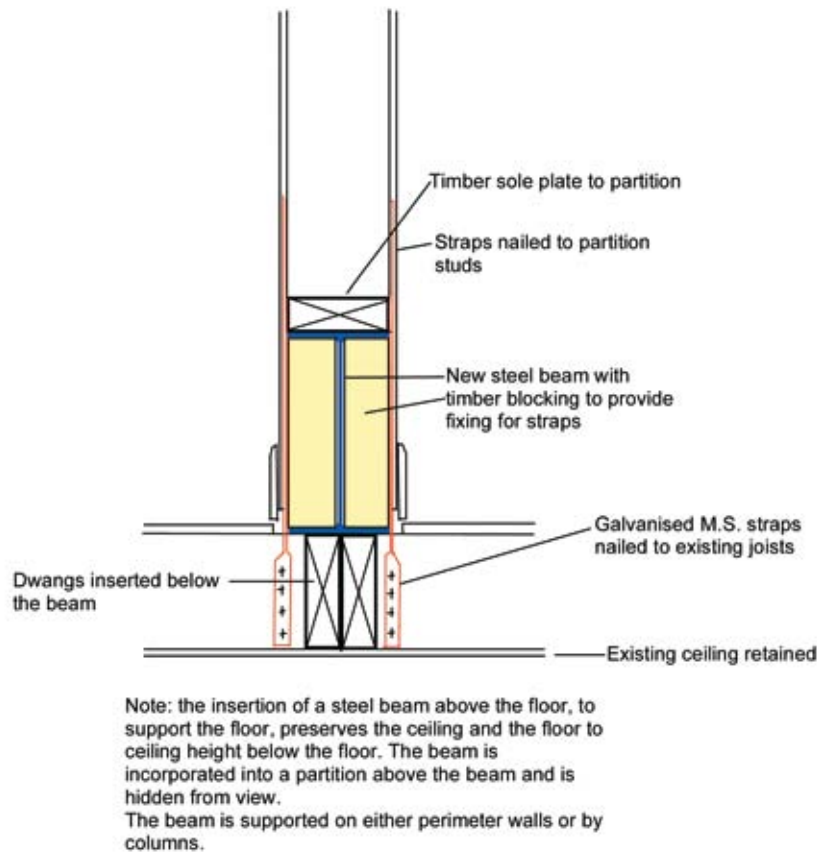

*Illus 1.1.6 Timber floor strengthened by a steel beam inserted above floor level.*

remain wet for some time after the dampness source has been eliminated, it is important to ensure that all timber is protected with preservatives and that air is free to circulate around the timber within the pocket.

Typically, timber floors are strengthened by the insertion of steel beams, supported by either flank walls or new columns. The introduction of beams and their supports can be very destructive to historic character and fabric if they are insensitively designed and located. Usually this means that beams support the underside of floor joists and project into the room below – often leading to loss of important plaster cornices. In some situations it is possible to use the line of a partition being supported by the floor to act as a locus for the beam, as shown in Illus 1.1.6. In this case the beam is designed to fit into the space occupied by the partition and is hidden from view, while causing a minimum of damage to existing finishes. However, locating a beam in this position will mean that door openings are not available within the partition.

An alternative approach to providing additional support to a timber floor may be by the use of a braced partition, tied back to and supported by load-bearing flank walls, as shown in Illus 1.1.7. An existing partition can be strengthened by adding diagonal bracing, or a new partition inserted where this is possible without disruption to the internal character of the space.



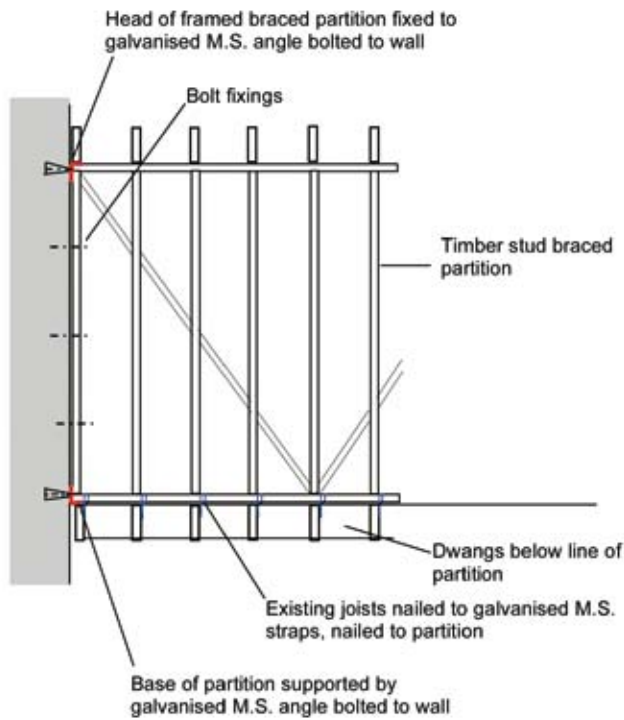

Illus 1.1.7 Braced partition providing additional support to an existing floor.

*Beam strengthening*

There may occur situations where it is necessary to retain an existing floor structure where the construction of the floor, including existing timber beams, is an important factor in defining the character of the building. In such cases, where the bearing capacity of a beam has to be improved, every effort must be made to achieve this without causing serious disruption to the historic elements. There are a number of ways in which this can be achieved; those shown in Illus 1.1.8 are examples of strengthening and conserving a historic timber beam.

In situations where a timber beam is incorporated within the depth of the floor, a rather more simple solution can be adopted while preserving the beam in situ. The example in Illus 1.1.9 requires removal and reinstatement of the ceiling below the beam but by bolting two galvanised steel angle sections to the bottom of the beam the load bearing capacity is greatly improved and deflection of the beam controlled.

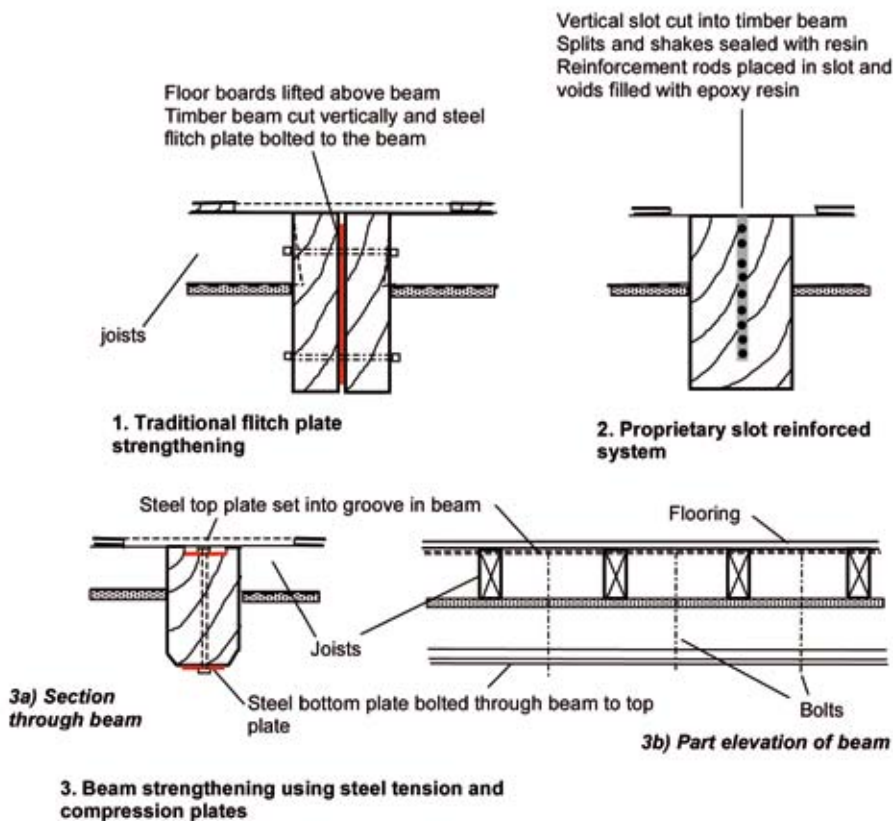

Illus 1.1.8 Methods of strengthening existing timber floor beams. In this case the beams are exposed within the ceiling below and this feature is retained.

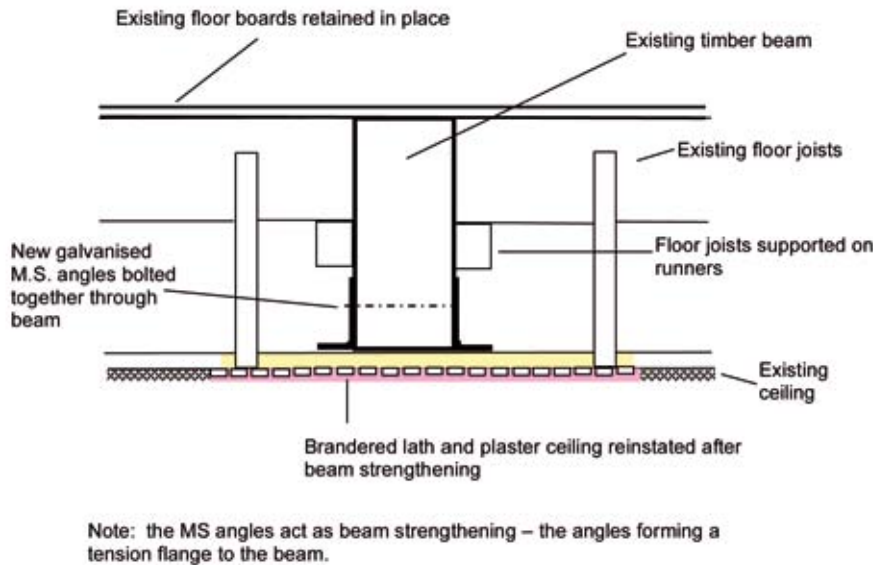

*Illus 1.1.9 Beam strengthening of timber beam wholly within the floor to ceiling zone.*

#### *Replacement lintels*

Openings in traditional masonry walls are normally supported by timber lintels (typically 150mm wide by 100mm deep). Typically, a stone lintel is used when the outer face of the wall is exposed stone or is finished in render with stone margins around the openings. Alternatively, all the lintels may be constructed from stone.

Timber safe lintels are vulnerable to moisture-related damage from damp walls. It is thus essential to ensure that all timber lintels are in sound condition and, where decay is present, the source of the moisture is identified and rectified and the decayed lintels replaced with new lintels as shown in Illus 1.1.10. In general, whenever supporting elements in masonry walls are removed, propping of the wall above will be required.

#### *'Cantilevered' Stairs*

There are many situations in the conversion of a historic building where existing stone, or timber, cantilevered stairs have to be retained and required to support increased loadings. Such stairs formed the principal staircase in many town and country houses and are thus important in defining the character of the building. While these stairs have passed the test of time and are structurally sound, engineers have been unable to provide detailed structural calculations to prove the ability of a stair to support increased imposed loads. There are therefore concerns about their real strength.

While the ends of the steps are built into a masonry wall and the stone then 'cantilevered' out, the stair does not act as a true cantilever as the load is transferred down through the steps to the lowest step and then to the supporting floor. Each tread carries the weight from above on its back edge and is supported under its front edge by the tread below (Price and Rogers 2005). The bearing capacity of the wall (which does carry a torsion force), the condition of the masonry around the built-in end of each step (or landing), the bearing of one tread upon another and the strength of the supporting floor all contribute to the stability of the stair.

According to Price and Rogers (2005) when assessing the strength of an existing staircase, the unknowns may include:

- the strength of the stone in the staircase,
- the quality of the material in the supporting wall,
- the quality of the mortar between the treads,
- the way the staircase was built (ie tread on tread, or the whole flight on centring),

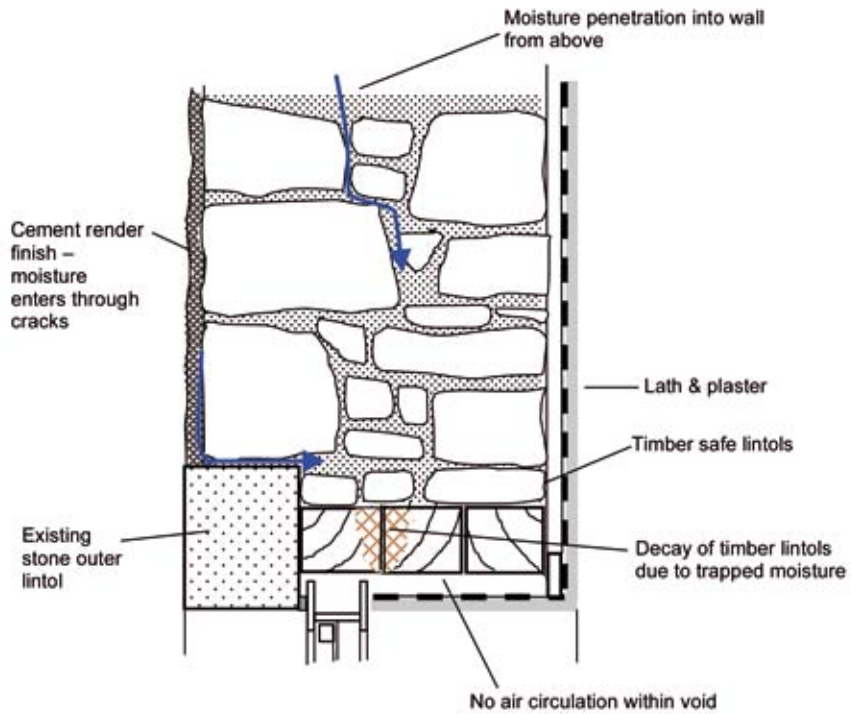

(a) Section through traditional rubble wall at window/door head

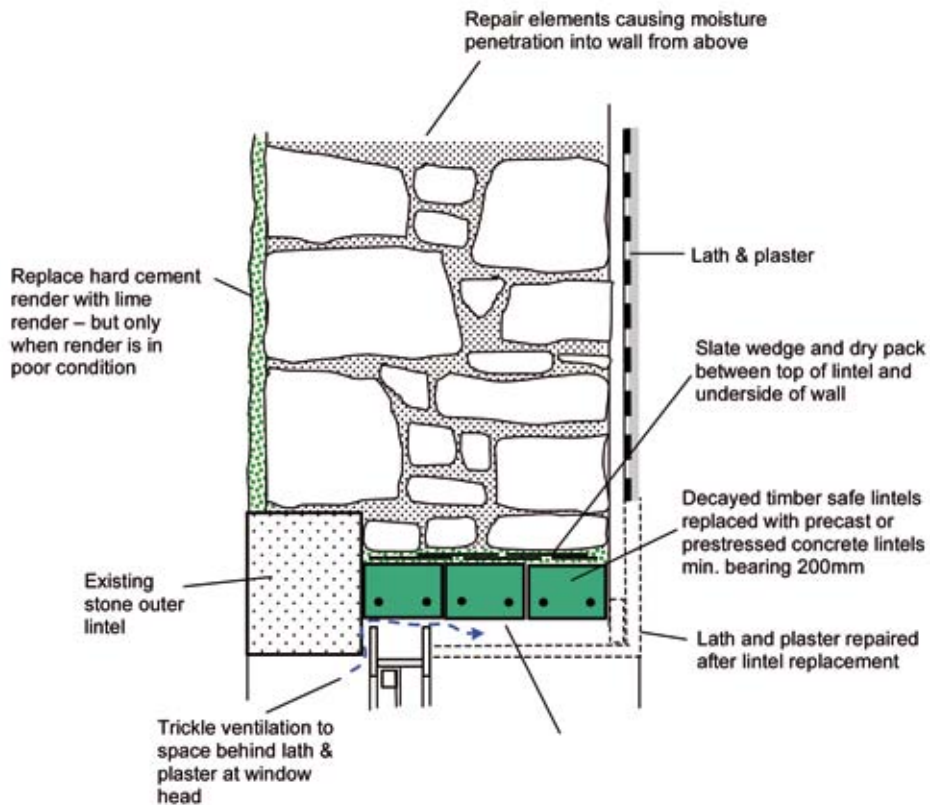

(b) Replacement of safe lintels

*Illus 1.1.10 Replacement of decayed timber safe lintels with precast concrete lintels.*



*Illus 1.1.11 Fine example of cantilevered stone staircase in this former hospital converted to offices. Note the slenderness of the self-supporting stone steps and the original iron balustrade. (Photo: Historic Scotland).*

- the vertical and horizontal support provided at the top and bottom of the flights,
- the way the landing slabs have been jointed and
- the strength and stiffness of the handrail.

As a result, the only practical means of determining whether the stair has the ability to support the actual loads to be imposed, as a result of a change in use, is to subject the stair to a load test. Price and Rogers also state that a flight with rebated treads has even more unknowns than a flight with plain treads.

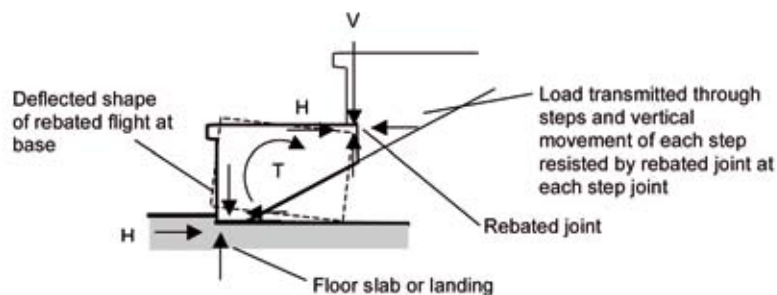

**Forces acting on individual steps and at base of stair.**  
Load from above coming down on back of tread is carried by torsion in the tread to the tread below (from Price and Rogers 2005)

*Illus 1.1.12 Forces acting on steps in a 'cantilevered' stair. Note: the support is not due to cantilever action. (from Price and Rogers 2005).*

**1.1.5 Related standards**

Other related standards are:

- Standard 3.6 Surface water drainage
- Standard 4.2 Access within buildings
- Standard 4.3 Stairs and ramps
- Standard 6.6 Mechanical ventilation and air conditioning.

## 2. FIRE

### Preface to Fire Standards

The guidance offered by the Technical Handbook with respect to fire standards is designed essentially for new build and, as such, the strict application of the guidance has the potential, when applied to historic buildings, to cause significant loss of historic fabric and character. However, safety of life in a fire situation is paramount, and this is reflected in the design of the standards; nine of the fifteen fire standards demand that the conversion shall *meet the requirement of the standard*.

Historic buildings were generally constructed without regard to fire risk and were constructed without the levels of fire resistance now required for new construction. For example, deliberate compartmentation to confine the outbreak of fire or adequate consideration of escape routes simply did not exist. The buildings themselves therefore create fire safety problems where the presence of certain features actually assist the rapid spread of fire. Most historic buildings will contain undivided roof spaces and other hidden voids where a fire can smoulder unseen and break out at a point remote from the seat of the fire. Interconnected voids are a major hazard that must be accurately identified during the initial building surveys. To further complicate the issue, most historic buildings will have undergone alterations and changes throughout their life, where features such as ducts, chases, shafts (including lift shafts, ventilation spaces and old staircases), and chimneys and flues may have been built over and forgotten. They thus provide an easy route for heat, fire and smoke to spread throughout the building.

When considering the requirements of the standards and the conservation needs of a historic building there may be conflicts of interest between the need to provide an appropriate level of fire resistance and the preservation of historic character. It is essential, therefore, to strike a balance between fire-safety provision and relevant conservation issues to arrive at the optimum solution in any given situation. In general, every historic building is unique and solutions must be tailored individually to each building. This means that alternative approaches to fire safety must be considered so that the specific nature of the building and its construction are built into the equation. A fire engineering approach to fire protection, based on a thorough **fire risk assessment**, will almost certainly be required in the application of fire standards to historic buildings.

The attention of practitioners is drawn to BS 7974, *Application of fire safety engineering principles to the design of buildings*. The BS can be used as an alternative to the guidance provided in the Technical Handbook, either in whole or in part. It provides a disciplined and structured approach, which compares alternatives and provides opportunities for innovative design solutions. For example, a historic door may not need to withstand the effects of a fire much beyond the time it takes to evacuate the building, provided the time available to evacuate is reduced through, for example, an effective and reliable fire detection and warning system.

Alternative strategies may thus compensate for deficiencies in the passive fire resistance of the fabric and layout of the building through the use of active measures such as automatic fire detection and suppression systems. Alternatively, a combination of schemes might be introduced based upon a thorough assessment of risk, a hazard reduction exercise and the implementation of a good management strategy, in accordance with the guidance in BS 5588 Part 12: 2004.

Many historic buildings are in remote locations and thus have the potential to present a greater risk to life or to the property itself. Where fire crews are required to travel some distance to reach affected property there will be a significant time lapse between ignition and their arrival. The larger the interval of time the greater the opportunity for fire growth. Unless some form of intervention takes place meantime, perhaps by automatic fire suppression, the first attack may take place only on the arrival of the fire crew. Even adequate compartmentation will not protect the room on fire, only help prevent its spread to other parts of the building.

Effective fire risk management has a contribution to make in satisfying the standards. There is, within the new building regulations, a power to set '*continuing requirements*', which can impose an ongoing control that might relate to certain management actions. While management solutions alone are unlikely to satisfy the requirements of the standards, they may make a contribution. This will depend on the particular circumstances, and may involve

a ‘*continuing requirement*’ being imposed on the building owner. Any role of management in meeting the standards must be agreed with the verifier and the enforcing authority for fire safety legislation. There is now, however, a possible role for management solutions to help achieve compliance, which did not exist under the previous regulations.

## 2.1 Compartmentation

### Standard 2.1

Every *building* must be designed and *constructed* in such a way that in the event of an outbreak of fire within the *building*, fire and smoke are inhibited from spreading beyond the *compartment* of origin until any occupants have had the time to leave that *compartment* and any fire containment measures have been initiated.

**Limitation** This standard does not apply to *domestic buildings*.

#### 2.1.1 Type of standard

##### *Mandatory standard*

In the case of *conversions*, the *building as converted* must meet the requirement of this standard.

#### 2.1.2 Commentary

In the conversion of a historic building, the need to prevent the growth of fires by ‘containment’, so avoiding major conflagrations, is one of the principal design issues in order to ensure the safety of persons both in and around the building. Rather than creating larger and more open plan structures, many conversions of historic buildings involve a change of use where the building is divided into smaller self-contained units (such as apartments), or to a use where areas of the building must be sub-divided into inter-connected compartments (such as an hotel or residential care home). Whatever the situation, the existing and potential fire loading should always be carefully considered prior to deciding upon any particular strategy.

Historic buildings are often considered to be at greater risk from fire because of how they have been constructed. Most buildings erected before 1900 will lack any intentional forms of fire compartmentation or inbuilt fire resistance. In addition, many such buildings contain large, undivided roof spaces: unstopped voids, shafts and other vertical openings along or up which fire and smoke can spread. Chapter 3 of Historic Scotland’s Technical Advice Note 11 (Allwinkle et al 1997) discusses these problems in fuller detail. However, because of the typically short spans of traditional timber floors, most historic buildings will contain natural lines of compartmentation that may be incorporated into the design of conversions.

Compartmentation is the simplest means of inhibiting rapid spread of fire, smoke, heat and toxic gases. It will assist in helping occupants to evacuate the building and fire-fighters entering for the purposes of search and rescue and ultimately extinguishing the fire.

In assessing compartments, it is necessary to consider all the boundaries to each compartment (normally the walls, ceilings and floors) for integrity and resistance to fire. In many historic buildings, the integrity of the boundaries will be compromised by openings such as doors, service ducts and other weaknesses. In addition, most historic buildings will have undergone alteration and repair, which may have further compromised the fire integrity of the construction. Nevertheless, it is still possible to improve the fire performance of the existing construction while retaining or restoring historic finishes.

The intention of this mandatory standard is to *limit the severity of the fire* and, while every effort must be made to improve the fire resistance of compartments, there may reach a point where improving the fire resistance further could lead to loss of important historic fabric. In such circumstances it may be possible to adopt a fire engineering approach, which will balance weaknesses in compartmentation with other measures that will speed up the process of evacuation and or facilitate fire-fighting. These other measures may include the adoption of a fire engineering methodology along with improved fire safety management, detection and suppression.

When the conversion of a historic building is being considered, then a full fire risk assessment should be undertaken to determine whether the anticipated purpose is reasonable and appropriate. Historic Scotland Technical Advice Note 28 (Kidd 2005) explains how this should be undertaken and covers not only the risk assessment process but also the implications of changes of use.

### 2.1.3 Issues to be considered

Issue	Risks to historic/traditional buildings
1. Maximum compartment areas vertical and horizontal fire breaks	<ul style="list-style-type: none"> <li>• Large unpartitioned spaces are common: fires are able to spread rapidly and occupants may have difficulty escaping unaided. Sub-dividing historic spaces to comply with maximum compartment area requirements can be destructive to the historic character of the space and the building.</li> </ul>
2. Standards of fire resistance (short, medium and long)	<ul style="list-style-type: none"> <li>• Existing elements of structure may be inherently fire resistant while some may not; however, there may be additional difficulties faced in ensuring that barriers surrounding fire compartments provide the required standard of fire resistance.</li> </ul>
3. Smoke and heat exhaust ventilation systems	<ul style="list-style-type: none"> <li>• Malls in shopping centres and large shops in excess of 5,600m<sup>2</sup> should be fitted with smoke and heat exhaust ventilation systems (SHEVS), which are rarely present in historic buildings. Their introduction, unless existing voids or shafts can be used, will often result in unacceptable levels of damage to historic fabric.</li> </ul>
4. Buildings with different uses	<ul style="list-style-type: none"> <li>• Introducing higher than average fuel loads into, for example, where a hotel or retail occupancy is anticipated, can increase the fire risk. While there have been many successful conversions of historic buildings to offices, hotels, retail premises and for cultural use, care must be taken to consider all likely impacts of the new use.</li> </ul>
5. Residential buildings	<ul style="list-style-type: none"> <li>• The need for every upper storey and every basement storey to form a separate compartment in a conversion to a residential building will normally require improvements to the fire resistance of separating floors and/or ceilings, which may be destructive to historic features.</li> </ul>
6. High rise buildings	<ul style="list-style-type: none"> <li>• The requirement for every floor at a storey height of more than 18m above the ground to be a compartment floor may be difficult to achieve if historic finishes are to be retained, for example in the conversion of a large historic house to a hotel.</li> </ul>
7. Basements	<ul style="list-style-type: none"> <li>• Where there is a basement, the ground floor should be a compartment floor, unless there are not more than one basement storey and two other storeys, and each storey has an area of not more than 280m<sup>2</sup>. In most situations it should be relatively easy to make the ground floor a separating floor, as basements in historic buildings generally do not contain significant historic fabric.</li> </ul>
8. Places of special fire risk	<ul style="list-style-type: none"> <li>• These will include:                             <ul style="list-style-type: none"> <li>- electrical intake rooms/switchrooms,</li> <li>- transformer sub stations,</li> <li>- boiler and plant rooms,</li> <li>- lift motor rooms.</li> </ul> </li> </ul>
9. Fire-fighting shafts, smoke venting shafts & lift wells	<ul style="list-style-type: none"> <li>• It may be impossible to provide these in accordance with the normal standards and, where this is the case, a compensating feature such as automatic fire suppression may have to be provided.</li> <li>• Compartment walls with medium fire resistance duration should enclose a lift well. While the provision of such walls can be damaging to historic fabric, consideration should be given to upgrading the fire resistance of the lift shaft and doors and also to high level venting of the shaft.</li> </ul>
10. Openings and service penetrations	<ul style="list-style-type: none"> <li>• There is a danger that, in trying to improve the fire resistance of doors in compartment walls, historic doors and associated elements are lost or compromised.</li> <li>• It is likely that there will be little in the way of sealed penetrations or provision of dampers etc in ductwork and other service openings. However, fire stopping such openings is not normally damaging to historic fabric.</li> </ul>
11. Junctions	<ul style="list-style-type: none"> <li>• Fire stopping at junctions of compartment floors and walls can be a problem in historic buildings as there is a need to provide sufficient air movement to control humidity in hidden voids and spaces.</li> <li>• There is a need to continue compartment walls into roof voids and attics, and to ensure an effective fire stop at the junction with roof substrate. This requirement is unlikely to pose a threat to historic fabric.</li> </ul>
12. Fire resisting ceilings	<ul style="list-style-type: none"> <li>• Historic ceilings, and their junction with compartment walls, are likely to have limited fire resistance and upgrading their fire resistance may mean a loss of historic fabric.</li> </ul>



#### **2.1.4 Recommendations to meet the standard**

Maximum compartment sizes may be increased where there is an automatic fire suppression system fitted. Furthermore, where such active protection is installed, there may also be opportunities to reduce the periods of fire resistance normally required.

Where compartments are overly large, the limited presence of combustible items (such as may be found in a museum or picture gallery) may offer sufficient compensation provided that the fire risk is well managed in accordance with BS 5588 Part 12: 2004. In certain circumstances, however, it may be necessary to carry out a full fire engineering analysis in order to identify fire growth potential, in accordance with BS 7974.

In extreme cases the installation of new fire rated floor over an existing historic floor may be a practical and alternative solution. This is particularly so when the new structure can be removed at some future time, without impacting upon the original feature.

Contrary to some views, solid wood doors provide a reasonable degree of fire separation and even panelled doors have been known to resist the spread of fire for 15–20 minutes. The requirement to replace original doors with modern rated fire doors is one of the most contentious issues in the process of modifying historic buildings for new uses. However, the careful use of intumescent coating systems (paints and varnishes) can provide a reasonable standard of fire protection to timber doors and panels for up to 60 minutes.

Upgrading penetration protection is not a difficult process given the range of modern fire resisting compounds and materials (such as fire resistant cable transits) that are available. Where a building is being rewired there should be a good opportunity for carrying out local fire stopping and even upgrading fire compartmentation.

There is likely to be little inbuilt fire resistance in respect of ceilings in properties constructed before 1900. It is possible to introduce modern fire resistant materials in such areas, for example under-floor fire barrier curtains, which might be installed with minimal disruption to historic fabric when floors are being removed for re-wiring. Moreover, as with doors, there are intumescent products available for treating wood, steel, concrete and plasterboard that can be used to treat ornate ceilings.

#### **2.1.5 Related standards**

Other related standards are:

- Standard 2.2 Separation
- Standard 2.3 Structural protection
- Standard 2.4 Cavities
- Standard 2.5 Internal linings
- Standard 2.14 Fire service facilities
- Standard 2.15 Automatic life safety fire suppression systems
- Standard 3.14 Ventilation
- Standard 3.15 Condensation
- Standard 5.1 Resistance to sound transmission.

## 2.2 Separation

### Standard 2.2

Every *building*, which is divided into more than one area of *different occupation*, must be designed and *constructed* in such a way that in the event of an outbreak of fire within the *building*, fire and smoke are inhibited from spreading beyond the area of occupation where the fire originated.

#### 2.2.1 Type of standard

##### **Reasonably practicable standard**

Every *conversion*, to which these regulations apply, must be improved to as close to the requirement of the standard as is *reasonably practicable*, and in no case be worse than before the *conversion*.

#### 2.2.2 Commentary

This standard (Standard 2.2) should be read in conjunction with Standard 2.1, *Compartmentation*. However, 2.1 is an *essential* standard, which applies to non-domestic buildings only, while 2.2 is a *reasonably practicable* standard and applies to both domestic and non-domestic buildings. The essential differences between the two standards are:

- Standard 2.1 defines the maximum compartment areas for different non-domestic building use, and the minimum fire resistance duration for compartments and elements of structure; to *inhibit* fire and smoke spread and thus enable occupants to escape from the compartment and fire-fighters to enter.
- Standard 2.2 is concerned with the need to *prevent* fire spread from one dwelling to another (domestic buildings) or from buildings, or parts of a building, in different occupations (non-domestic buildings). This is because of the difficulty, in all cases, of ensuring a consistent and good standard of fire safety management and the increased life risk that consequently might arise. It covers the design and construction of separating elements which have to provide a complete barrier to the products of combustion.

The requirement of Standard 2.2 to provide separation of spaces that have a specified period of fire resistance is one that places possibly the most significant demands on the design and construction of historic building conversions. The most important elements that normally will have to be upgraded – or alternative strategies adopted – are the doors, floors, walls, penetrations through floors and walls, and roof voids.

A particular problem in historic buildings is the presence of multiple flues that may be present in separating walls. The majority of rooms will have had a fireplace and many redundant flues are likely to be unlined and in uncertain condition. Over many years, perhaps centuries, mortar becomes detached and gaps occur, which can permit the transfer of the products of combustion across separating elements. Similarly, ends of beams and floor joists built into separating walls may be a source of weakness that can permit the passage of fire and smoke across the wall.

Historic buildings will also contain hidden voids as a result of the method of construction, or redundant spaces that are now covered up. The traditional methods of construction result in cavities behind lath and plaster that permit the free circulation of air, which controls the moisture content of timber within these spaces. In addition, most historic buildings are likely to have undergone some degree of alteration over the years, for example the introduction of modern building services. As a result, the original structure may have been built over, creating voids. Often, the careless installation of services over many years has resulted in the creation of pathways within the construction that will destroy its effectiveness as a fire barrier.

The identification of voids in the design of a conversion is necessary to ensure the integrity of fire (and sound) separation between parts of buildings in separate occupation. Also, understanding the role of these voids in a historic building is crucial, as the thoughtless sealing up of such voids can adversely affect how such buildings ‘breathe’ and possibly leading to fungal decay and deterioration of porous plaster finishes and the like. Balancing the need for fire integrity while maintaining air movement is thus a significant challenge to designers.

Separating walls are required to extend into roof spaces and into solums, and are an absolute necessity for preventing fire spread between dwellings, or between one part of a building and another. It is always worth remembering that, while improving fire resistance of elements may cause some disruption to historic materials, the option to ‘do nothing’ is not appropriate, as weaknesses in the fire resistance duration could lead to the complete loss of the building and even loss of life.

### 2.2.3 Issues to be considered

Issue	Risks to historic/traditional buildings
1. Separating walls and floors	<ul style="list-style-type: none"> <li>• Generally, traditional lath and plaster finishes cannot be relied upon to provide the necessary period of fire resistance – especially at junctions and where the plaster is in poor condition – and thus will compromise the integrity of separating walls and floors. Upgrading timber floors may cause significant loss of historic materials and finishes.</li> </ul>
2. Combustibility	<ul style="list-style-type: none"> <li>• Most historic buildings do not have any storey at a height of more than 18m, in which case separating floors and walls may be constructed from combustible materials (for non-domestic buildings refer to the standard for the particular situations where this applies). While this should mean that major replacement of structural materials may not be necessary, upgrading of performance may be required with consequent loss of historic finishes, unless alternative strategies are employed (<i>refer to Section 2.2.4 below</i>).</li> <li>• For storeys at a height of more than 18m, separating walls and floors are required to be constructed from non-combustible materials. This requirement may result in the drastic reconstruction or replacement of walls and floors, which is likely to be unacceptable in most historic buildings. Alternative strategies to improve fire resistance will be necessary in such cases.</li> </ul>
3. Openings (esp. doors), service penetrations, chimneys or flue pipes	<ul style="list-style-type: none"> <li>• Doors in separating walls are required to have the same period of fire resistance duration as the wall (will generally be a minimum of medium fire resistance duration), although in some instances a self-closing fire door with short fire resistance duration may be installed. Upgrading historic doors to meet the standard of fire resistance required will frequently lead to loss of the historic character of the door (<i>refer to the advice in 2.2.4 below</i>).</li> <li>• Existing and new service penetrations should be fire stopped. Fire stopping is unlikely to pose a serious risk to historic fabric.</li> <li>• Existing chimneys and flues in masonry walls may be critical to the fire performance of the separating wall where the condition of stonework and pointing is poor. Improvements to fire resistance is thus essential but must be carried out in a sympathetic manner.</li> </ul>
4. Junctions	<ul style="list-style-type: none"> <li>• For many historic buildings with separating timber floors, fire stopping the junction between floor and wall to provide a permanent seal will reduce air movement in cavities and increase the risk of fungal decay of timber.</li> </ul>

### 2.2.4 Recommendations to meet the standard

#### 1. General recommendations

There is unlikely to be any significant degree of intentional fire separation in most historic buildings. Determination of what is present can often be difficult without damaging historic fabric and a specialist survey using endoscopes or fibre optic TV cameras may be the only way of determining what lies inside a wall or under a floor. The greater part of the building or structure, other than masonry or bricks, will burn and even where non-combustible materials (such as slates) are present, these will be supported by combustible timber and sarking. However, the following guidance may prove helpful:

- a) Lath and plaster will give only a very short period of fire resistance. However, intumescent coatings are available that can improve the standard of fire resistance to 30 or even 60 minutes, but only where the lath and plaster remains in place and the plaster does not detach from the laths as a result of thermal movement etc.
- b) Close-boarded floors on substantial joists may provide longer periods of fire resistance than is normally anticipated. There will be few such floors that will not provide 30 minutes fire resistance and most will provide at least 60 minutes resistance. Where pugging in the form of cinder ash or crushed sea shells has been introduced this will increase the resistance to fire.
- c) Existing doors may not offer any formal evidence of fire resistance but this does not mean that they provide no resistance. Again, the use of intumescent varnishes and paints can improve fire ratings and specialist advice should be sought.

While automatic fire detection will be (or should be) installed in all domestic properties, it will not usually be linked to any common or neighbouring alarms. Where, however, there are difficulties in ensuring the proper standard of fire separation between different occupancies, consideration should be given to providing fire detection and alarm systems to BS 5839 Part 1.

Similarly, the presence of automatic fire suppression, such as an automatic fire sprinkler system designed and installed to either BS 9251: 2005 or BS 5306 Part 2: 1990 may, in certain circumstances, provide adequate compensation. However, in this particular circumstance the issue of maintenance will clearly be an important matter requiring careful consideration.

Good ventilation and airflow is an important feature often required in many historic buildings. However, vents in walls, doors or floors that are also required to prevent the spread of fire can be acceptable if suitable products are installed that will seal in the event of fire e.g. automatic dampers or intumescent grilles.

## 2. Upgrading fire resistance duration of floors

There are various means of upgrading the fire resistance duration of existing timber separating floors. The most appropriate method will be determined by the required period of resistance, the historic importance of the floor and the construction and condition of the floor. For these floors the following methods of upgrading performance could be considered. The examples illustrated are reproduced, in part, from BRE Digest 208 1988, *Increasing the fire resistance of existing timber floors*, where more detailed information on specification and fixings can be obtained.

- a) Applying a layer or layers of plasterboard to the underside of the existing floor. However, this method is appropriate only where the existing ceiling is of no significance to the historic character of the building (Illus 2.2.1(a)).

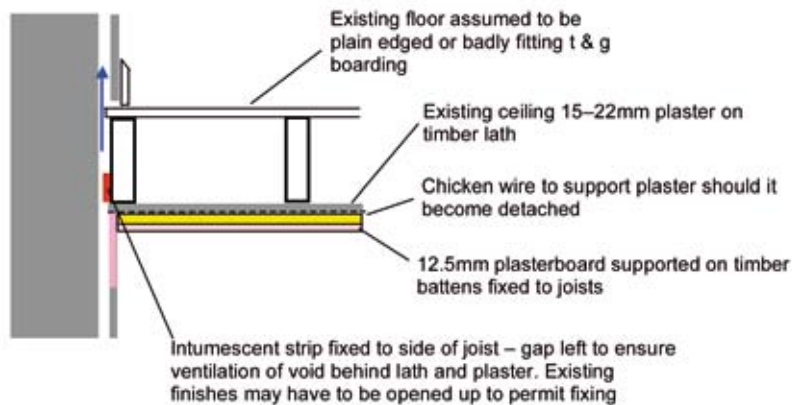

**(a) Fire protection added to underside of existing ceiling: half-hour protection**  
**Note:** for one-hour protection battens and plasterboard substituted by 13mm lightweight plaster on metal lathing.

*Illus 2.2.1(a) Half-hour fire protection added to underside of existing ceiling.*

- b) Installing a fire resisting suspended ceiling system beneath the existing floor may be appropriate when high fire resistance duration is required and where the floor to ceiling height permits. The existing historic ceiling may then be preserved within the new construction.
- c) Installing a lightweight underfloor fire-resisting barrier within the depth of the floor is useful when the existing ceiling and its fixing to the joists are in good condition (Illus 2.2.1 (b) and 2.2.1 (c)). In addition to the examples illustrated, proprietary systems are available. Usually, such systems require a few floor boards to be lifted and, for example, foil-clad intumescent material slid between the joists and fixed with battens. This system allows the historic ceiling to be retained while possibly achieving in excess of 100 minutes of fire resistance.

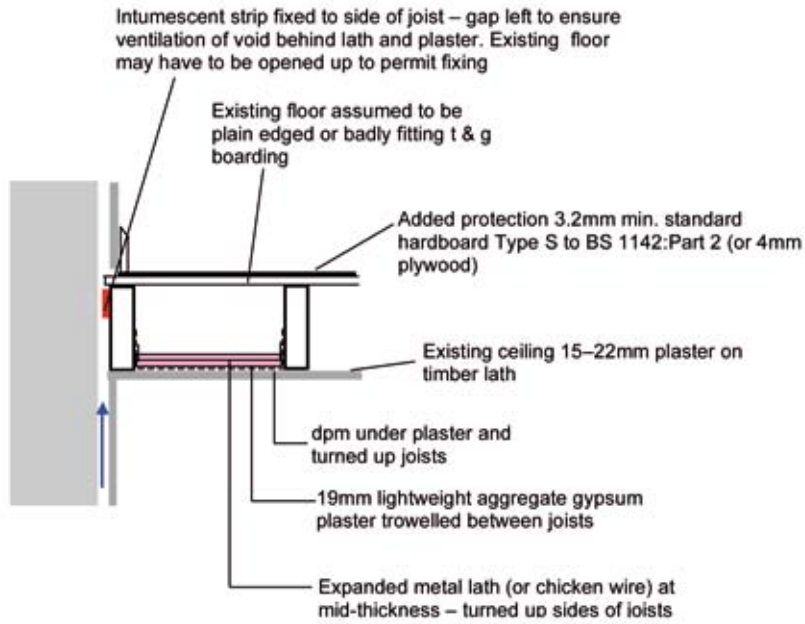

**(b) Fire protection applied from above existing floor: one-hour resistance**

*Illus 2.2.1(b) One-hour fire resistance added within the floor to preserve historic ceiling.*

- d) One of the least damaging methods of improving the fire resistance of a separating floor to achieve half-hour fire protection while retaining the existing ceiling is by adding a hardboard or plywood layer to the surface of the existing floor (Illus 2.2.1(c)).

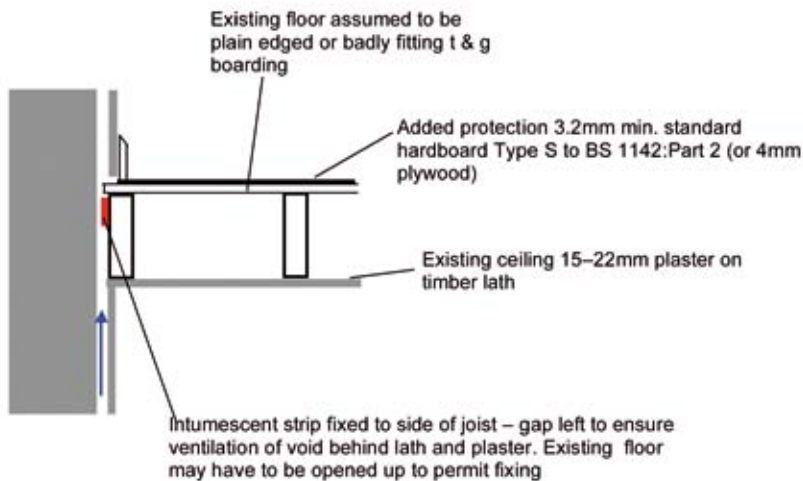

**(c) Fire protection applied from above existing floor: half-hour resistance**

*Illus 2.2.1(c). Half-hour fire resistance applied from above to existing floor.*

- e) Where existing joists are exposed it is possible to upgrade the floor by adding plasterboard protection below the flooring to achieve half-hour protection (Illus 2.2.1(d)).

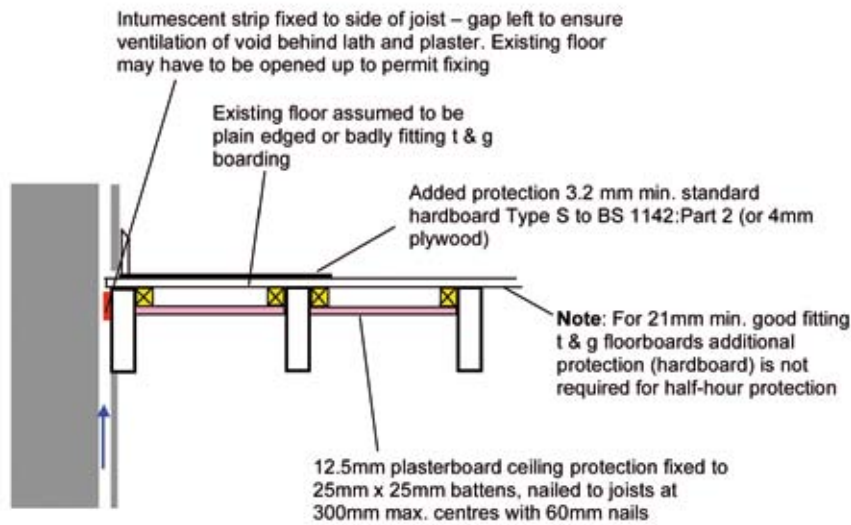

Illus. 2.2.1(d). Fire protecting a floor with existing joists exposed.

- f) Applying intumescent paper to the surface of the ceiling may be sufficient to improve the fire resistance duration to meet the short duration requirement. It can be used only where the lath and plaster are well fixed.

When upgrading the fire resistance duration of a historic timber floor, it is essential to provide resistance to the junction between the floor and the wall. However, sealing the gap between the floor and the wall will prevent the ventilation of voids behind lath and plaster wall finishes. For further information on this issue, refer to the advice contained in Part II, Standard 2.4 Cavities.



Illus 2.2.2 Historic ceiling to separating floor in a country house hotel – the ceiling has had fire resistance duration improved by the addition of intumescent paper (Photo: Ian Gough).

### 3. Upgrading the fire resistance duration of doors in separating walls

Upgrading the fire resistance duration of a historic door in a separating wall is discussed in Section 6.1.4, Part 1, of this guide. Further information can be found in Historic Scotland TAN 11 (1997) and in TRADA publication, Sheet 32, (2005) *Fire resisting doorsets by upgrading*. However, the principal recommendations for improving the performance of these doors are summarised below (more detailed information is available in TRADA Sheet 32).

- a) For a framed door with solid panels it is important to identify the species of timber used to enable an estimate to be made of the potential burn-through time for the door and of its likely potential to distort. In addition, the condition of the door must be taken into account as any shrinkage or splitting will influence the burn-through time. The thinnest timber within the door should be used for this purpose. This will allow a decision to be made on how best to upgrade the performance of the door. Methods can include:
  - facing the door on both sides with non-combustible boards, which can be removed at a later date with minimal damage,
  - sealing all cracks and gaps with intumescent paste,
  - applying intumescent paper to protect vulnerable areas such as fielded panels,
  - applying intumescent paints and varnishes to doors and frames (usually in conjunction with other upgrading measures),
  - fitting proprietary intumescent strips and flexible cold smoke seals.
- b) In the case of a door with a glazed panel, the normal approach will be to replace the existing glass with fire resisting glass. However, this may mean that important historic glass is lost. In such a case it may be possible to apply secondary fire glazing to the door (using a suitable fire resisting glass), which retains the historic glass in place and allows the door to be returned to its original state, should the need arise.
- c) The gap between the door leaf and frame in a historic door opening is frequently wider than the 4mm maximum. The door and frame may have distorted over the years leaving a variable gap. In such cases, to allow the fitting of intumescent seals, the door leaf edges may need to be adjusted.
- d) It is not just the door leaf that will require attention. In order for the whole door installation (including the door frame construction, the frame to wall junction and ironmongery) to achieve at least a short fire resistance duration, the following steps to improve performance should be implemented.
  - fit intumescent strips across the head and down both jambs;
  - repair damaged frames where these affect fire performance;
  - carefully remove architraves to check that no voids occur between the frame and surrounding wall, and thus allow the passage of combustion products; and
  - fill any voids with plaster, intumescent material or tightly packed rock wool (or similar) insulation.
- e) Existing historic door ironmongery cannot be assumed to be suitable for use on a fire-resisting door. For example, large heavy iron latches and hinges can transmit heat rapidly and thus reduce the fire resistance of the door. Where this is the case, historic door furniture may need to be replaced with suitable approved fittings and the historic furniture stored carefully for possible refitting at a later date should building use change. In the case of a listed building this may be a matter for listed building consent. Alternative options relating to the use or management of the building may have to be explored where the fittings are important to the character of the building. Similarly, alterations to the door furniture over the life of the door may have resulted in gaps or reduced door thicknesses that should be filled with a timber insert piece.
- f) The introduction of fire detection and alarm systems and automatic fire suppression, as discussed in point 1 above, *General discussion*, will influence the extent to which improvements to the fire resistance of doors and door frames are required.

### 2.2.5 Related standards

Other related standards are:

- Standard 2.1 Compartmentation
- Standard 2.3 Structural protection
- Standard 2.4 Cavities
- Standard 2.5 Internal linings
- Standard 2.9 Means of escape
- Standard 2.11 Communication
- Standard 3.15 Condensation
- Standard 3.19 Combustion appliances – combustible materials
- Standard 5.1 Resistance to sound transmission

## 2.3 Structural protection

### 2.3.1 Type of standard

#### Standard 2.3

Every *building* must be designed and *constructed* in such a way that in the event of an outbreak of fire within the *building*, the load-bearing capacity of the *building* will continue to function until all occupants have escaped, or been assisted to escape, from the *building* and any fire containment measures have been initiated.

#### Mandatory standard

In the case of *conversions*, the *building* as *converted* must meet the requirement of this standard.

### 2.3.2 Commentary

For new build, this is a relatively straightforward standard that presents little difficulty to the designer. However, the conversion of a historic building can raise complex issues relating to the level of fire protection offered by an element of structure. Modern building materials are covered by appropriate British and European standards and fire test certification; but the performance of traditional, historic materials will be less well understood and many materials will not have the ‘security’ of such certification. A designer (or verifier) inexperienced in the conversion of historic buildings may consider that, in the absence of test data, it is necessary to adopt a ‘fail-safe’ approach and over-design structural fire protection, which may have an adverse effect on historic fabric.

It is essential, therefore, to understand the way in which materials have been combined to form an element of structure, and to appreciate how both the individual materials and materials used in combination affect the fire performance of the element. Such an understanding will take into account the effects of age, physical and chemical degradation, applied treatments and any other forms of degradation that will have an impact on fire performance. It is also important to know the likely impact that any applied protective coatings or finishes may have on the historic character of the element. More detailed advice on the performance of historic materials in fire is available in Historic Scotland Technical Advice Note (TAN) 11.

It is clear, therefore, that before embarking on the design of a historic building conversion it will be necessary to conduct a full survey and fire risk assessment of the structural elements and their likely performance in fire. In the absence of such a survey it will be impossible to determine the structural performance of the building in fire, or the extent to which upgrading of the elements – or the introduction of other measures – will be necessary. However, experience of real fires in historic buildings suggests that, in many cases, the load-bearing capacity of structural elements will be maintained for 30 minutes or more. For example, timber is a combustible material but the degree of fire resistance increases with thickness; the formation of a char layer inhibits further the effect of fire. However,



the condition of the timber is vital to the assessment of performance as fungal decay and insect attack, for example, will have a significant effect. Traditional lime or gypsum plasters have an inherent resistance to fire when in sound condition, but where the plaster is not firmly adhering to the substrate – especially to fir laths – its ability to resist fire is reduced significantly.

Failure of a structural element may not be due simply to the combustibility of the materials – the effects of heat can cause distortion resulting in the collapse of supported elements. For example, the expansion, buckling or other deformation of cast iron or steel columns or beams in the early stages of a fire can cause the collapse of supported floors.

### 2.3.3 Issues to be considered

Issue	Risks to historic/traditional buildings
1. Elements of structure	<ul style="list-style-type: none"> <li>• The majority of historic buildings undergoing conversion are of limited height, and many will not have a storey more than 7.5m above the ground. In this case elements of structure need only to have at least a short fire resistance duration, which can usually be accommodated without significant disruption to historic finishes and materials.</li> <li>• Where the building has a storey height over 7.5m and not more than 18m, a medium fire resistance duration is required. The majority of historic buildings will not achieve structural fire protection of this order without improvements to structural fire resistance, which may be destructive to historic materials and finishes. Specialist advice is required.</li> <li>• Buildings with a storey height over 18m above the ground are required to have a long fire resistance duration. In an effort to improve structural fire protection, there is potential for extreme loss of historic fabric. This is an area in which specialist advice is essential.</li> </ul>
2. Combustibility	<ul style="list-style-type: none"> <li>• The use of combustible materials is normal for elements of structure in historic buildings. The presence of such materials is acceptable provided the element achieves the appropriate fire resistance duration.</li> <li>• Structural timber, while combustible, may have appropriate fire resistance duration for the given situation. Unthinking ‘improvements’ to fire resistance of timber can be damaging to its historic character.</li> </ul>
3. Openings and service penetrations	<ul style="list-style-type: none"> <li>• Unlikely to present a risk to structural stability. However, past alterations to structural floors to install services and the like may have adversely affected the fire resistance of the element, and further intervention, to improve fire resistance, may be destructive to fabric.</li> </ul>
4. Junctions	<ul style="list-style-type: none"> <li>• Unlikely to present a risk to historic fabric in most situations. However, a fire risk assessment will be required to determine whether fire stopping at junctions of elements of structure is necessary. The installation of fire stopping may result in loss of historic fabric.</li> </ul>

### 2.3.4 Recommendations to meet the standard

#### 1. Fire risk assessment

While most of the main structural features will already have a limited degree of fire resistance inherent in them, it may be possible to demonstrate a reasonably adequate level of safety by carrying out a full and detailed fire risk assessment followed by a hazard reduction exercise. Limiting amounts of fuel present in a building, combined with few ignition sources and good management practice in accordance with BS 5588 Part 12: 2004 ‘*Managing fire safety*’, may in some cases be sufficient to satisfy the authorities having jurisdiction on this matter. Furthermore, occupancy factors, such as whether the premises are used for residential purposes or are day risk only, should also be taken into account when assessing the adequacy of existing materials. Finally, in some cases it may be necessary to carry out a full fire engineering analysis in accordance with BS PD 7974 2004.

#### 2. Improve fire protection

Even after carrying out a thorough fire risk assessment, it may still be necessary to improve the quality of fire protection to existing elements of structure and there are many ways of doing so without damaging historic features. Methods include:

- non-combustible materials, such as mineral fibre, can be used to clad structural members,

- enclose existing historic structures within new structures, such as floors, which can, at some future date, be removed without damaging historic features,
- intumescent paints and varnishes are available to treat a wide range of materials such as: steel, timber, concrete lath and plaster etc; however, intumescent pillows and fire stop blocks are also available and extremely useful for ensuring fire-stopping around columns and beams.

### 3. Install active fire-defence systems

Active systems of fire defence such as fire suppression and alarms may also be used to compensate for weaknesses in structural fire protection or where confidence in the quality of existing measures is low. Some of these circumstances are already recognised within the Technical Handbooks:

- for buildings with different uses (non-domestic), fire sprinklers allow shorter fire resistance duration,
- reduced fire resistance of external walls is permitted if fire sprinklers are present. also reduced boundary distances are permitted for shop, entertainment, class 1 factory and storage buildings if sprinklers are present,
- basements can be provided with mechanical ventilation for fire service use if they have automatic fire suppression.

### 2.3.5 Related standards

Other related standards are:

- Standard 1.1 Structure
- Standard 1.2 Structure – Disproportionate collapse
- Standard 2.1 Compartmentation
- Standard 2.2 Separation
- Standard 2.4 Cavities
- Standard 2.5 Internal linings
- Standard 2.14 Fire service facilities
- Standard 5.1 Resistance to sound transmission
- Standard 6.2 Building envelope insulation

## 2.4 Cavities

### Standard 2.4

Every *building* must be designed and *constructed* in such a way that in the event of an outbreak of fire within the building, the unseen spread of fire and smoke within concealed spaces in its structure and fabric is inhibited.

#### 2.4.1 Type of standard

##### *Reasonably practicable standard*

Every *conversion*, to which these regulations apply, must be improved to as close to the requirement of the standard as is *reasonably practicable*, and in no case be worse than before the *conversion*.

### 2.4.2 Commentary

In all buildings the spread of fire and smoke in concealed spaces must be a primary concern in fire safety design, as fire can spread undetected and very rapidly within such spaces. The risks are increased significantly in historic buildings, where cavities and pathways for fire and smoke will be hidden within the construction and their presence may not be known without detailed investigation. Moreover, it is not unusual to find in very old buildings significant quantities of combustible material such as: off-cuts of timber, bird's nests, soot and other forms of combustible refuse that has been deposited within the cavities of walls over the years.

A further consideration is that historic buildings are required to breathe, which means that most cavities will be ventilated, thus raising the potential for more rapid fire spread. The undetected spread of fire within cavities has been responsible for many serious fires in historic buildings – especially because, once established, they are so notoriously difficult to fight and extinguish.

For the majority of historic buildings of masonry construction in Scotland, the most common method of applying the internal wall finish is with timber lath and plaster (or timber panelling), fixed with timber dooks to the masonry. This method of construction leaves a small, ventilated gap behind the lath and plaster, which frequently provides a ready pathway for the products of combustion into other ventilated spaces within floors and roofs. Sealing off these cavities to prevent the spread of smoke and fire may seem the simplest solution, but cutting off ventilation pathways and the process of inserting cavity barriers can be damaging to historic fabric.

The standard recommends that cavity barriers should be installed around the edges of cavities. Barriers, for example, are required around the head, jambs and sill of an external door or window opening and at a wall-head between a wall cavity and a roof space cavity. However, the difficulties where through ventilation has to be maintained are acknowledged in the standard. Designers of conversions must recognise that appropriate solutions will require a thorough understanding of the location of cavities; the risks posed by fire spread and by reduced ventilation within construction. It may be that alternative strategies to reduce the risks to occupants will have to be employed.

For the purposes of this standard, a roof space is also classed as a cavity, as it is often a high-risk area that can be quickly consumed by fire passing into the space through adjoining cavities. Often the cellular arrangement of walls on lower floors does not extend into the roof void, creating a large volume roof (refer to Standard 2.1, Separation, for further information). Large volume roofs, as encountered for example in the conversion of churches or public buildings, are vulnerable to fire spread. Also domes, which are often double skinned and have a timber supporting structure, have little fire resistance and allow rapid fire spread within the construction.



*Illus 2.4.1 The presence of large, unpartitioned roof voids has resulted in severe fire damage to the roof and interior of this Category A listed university building. (Picture by Leigh Johnston, Historic Scotland and reproduced here from TAN 28).*

**2.4.3 Issues to be considered**

Issue	Risks to historic/traditional buildings
1. Cavity barriers	<ul style="list-style-type: none"> <li>• The introduction of cavity barriers into historic buildings creates two significant problems:               <ul style="list-style-type: none"> <li>- sealing off a cavity will reduce the ventilation of voids and may promote dampness within the construction and</li> <li>- the process of inserting fire-stopping materials into historic construction can cause damage to historic fabric.</li> </ul> </li> <li>• The recommendation to provide cavity barriers around the edges of a cavity, for example around window openings, is impractical where existing finishes are retained.</li> </ul>
2. Roof space cavities	<ul style="list-style-type: none"> <li>• A cavity includes a roof space. Many historic roofs are likely to have ceilings constructed from lath and plaster, which, when in sound condition, may be capable of providing short fire resistance duration. But upgrading a ceiling to provide short fire resistance duration may mean loss of historic features.</li> </ul>
3. Cavities above ceilings in residential buildings	<ul style="list-style-type: none"> <li>• Where a ceiling void extends over a room intended for sleeping, a cavity barrier on the same plane as the wall is required. Alternatively, where this is not practical, a fire-resisting ceiling can be installed. However, each of these solutions can lead to damage to historic fabric. Existing ceilings may need to be disturbed to gain access to the roof space, and upgrading the fire resistance duration of the ceiling may mean loss of important features.</li> </ul>
4. Fire resisting ceilings	<ul style="list-style-type: none"> <li>• These may be used in place of cavity barriers in appropriate situations. The comments above apply.</li> </ul>
5. Combustibility	<ul style="list-style-type: none"> <li>• Cavity barriers and fire resisting ceilings provided as an alternative to cavity barriers generally need not be constructed of non-combustible material. No additional risk to historic fabric is posed by this clause.</li> </ul>
6. Supporting structures	<ul style="list-style-type: none"> <li>• No additional risk posed by this clause.</li> </ul>
7. Openings and service penetrations	<ul style="list-style-type: none"> <li>• No additional risk posed by this clause.</li> </ul>
8. Junctions	<ul style="list-style-type: none"> <li>• Cavity barriers are required to fit tightly to rigid construction. This may not be possible at a junction with slates, tiles or similar materials; in which case the junction should be fire stopped. For rooms contained within roofs, access for fire stopping may be destructive to finishes.</li> <li>• Where a separating wall or floor abuts a structure containing a cavity, as can be the case with lath and plaster lined structures, a cavity barrier should be installed to extend the line of the structure. This requirement can be a serious problem in historic buildings as installation of the barriers can be destructive to fabric and sealing off cavities at these locations will affect the ventilation of voids.</li> </ul>

**2.4.4 Recommendations to meet the standard**

- a) There is unlikely to be any significant degree of intentional fire separation in most historic buildings. All roof spaces should be carefully checked and assessed as part of the overall fire risk assessment. However, determination of what is present can often be difficult without damaging historic fabric and a specialist survey using endoscopes or fibre optic TV cameras may be the only way of determining what lies inside a wall or under a floor. The vulnerable locations are:
- areas around chimneys and flues should always be carefully checked and any waste combustible material and rubbish removed as a priority,
  - breaches in walls, ceilings and floors (particularly where electrical cables penetrate) and seal as appropriate.
- b) New barriers can be installed and, in addition to traditional materials, a wide variety of modern proprietary products are available, including:
- fire barrier curtains, both intumescent and mineral fibre, for fixing inside roof-spaces or floors and separating large voids;

- intumescent gaskets for PVC/metal electrical outlet boxes in ceilings and walls;
  - fire resisting covers/caps for recessed light fittings/downlighters and air conditioning units;
  - intumescent soffit vent grilles, roofing fire break membranes (for fitting over separating or compartment walls and preventing fire spread across a roof);
  - intumescent pads and pillows for metal electrical trunking in ceilings and walls.
- c) Where the building fabric cannot be disturbed or the installation of barriers is not practicable, consideration should be given to improving the level of automatic fire detection – or even installing automatic fire suppression.

#### 2.4.5 Related standards

Other related standards are:

- Standard 2.1 Compartmentation
- Standard 2.2 Separation
- Standard 2.3 Structural protection
- Standard 2.5 Internal linings
- Standard 3.14 Ventilation
- Standard 3.15 Condensation
- Standard 5.1 Resistance to sound transmission
- Standard 6.2 Building envelope insulation

## 2.5 Internal linings

### Standard 2.5

Every *building* must be designed and *constructed* in such a way that in the event of an outbreak of fire within the *building*, the development of fire and smoke from the surfaces of walls and ceilings within the area of origin is inhibited.

#### 2.5.1 Type of standard

##### **Mandatory standard**

In the case of *conversions*, the *building* as *converted* must meet the requirement of this standard.

#### 2.5.2 Commentary

This is an *essential* standard, which can have a significant impact on the conversion of a historic building because it is concerned with the ability of surfaces to restrict the spread of fire and smoke. The materials used to cover walls and ceilings can greatly increase the danger to people who are escaping from a building that is on fire, and they do so in two ways:

- they may burn very easily, spreading the fire from one end of a room or corridor to the other,
- they may give off poisonous fumes when heated.

Many of the important surfaces encountered in historic buildings, and which should be preserved in a conversion, can affect the spread of fire and its rate of growth. Some will be classified into high or very high-risk categories, for example, historic timber panelling. Fire spread on wall and ceiling linings in escape routes are particularly important in this respect.

The performance criteria set out in Annex 2.E, *Reaction to fire*, of this standard can be satisfied by either a British Standard fire test or European harmonised fire tests. Principally the standards applicable are contained in BS 476 Parts 6 & 7. Clearly, these tests apply to the specification of internal linings for new buildings and test data for historic linings may not be available. However, experience gained from the performance of particular materials in a fire situation may be used in the fire risk assessment of a historic lining.

*Timber linings*

Timber wall and ceiling linings are likely to be the most frequently encountered historic surface that will contribute to the spread of fire. They will burn readily and the presence of shakes, splits and shrinkage cracks will also contribute further to the fire risk. In addition, such linings may have been treated with waxes, polishes and paints, which tend to increase the flammability of the surface.

*Decorative treatments*

The standard excludes any decorative treatments, such as paints and wallpapers. However, while some paints, polishes and varnishes may themselves be liable to ignition, it is the heavy build-up of layers of paint over many years that make them potentially vulnerable to fire and the production of smoke and gases. To counter this effect, multiple layers are not recommended in the standard. However, the stripping back of multiple layers may destroy important historical information and, where paint removal from surfaces is being considered in historic buildings, listed building consent may be required.

For all historic linings and decorative finishes, a fire risk assessment is required. For the build-up of multiple layers of paint and wall coverings a fire risk assessment will normally include an exploration of the layers, perhaps involving paint scrapes or sampling of a discreet segment of wall covering for analysis. This analysis may also include a chemical analysis of paint layers to determine the composition of the paint and its fire risk potential. Such an investigation will also help to identify the historic importance of hidden layers and therefore assist in the development of a conservation strategy.

*Plaster surfaces*

The majority of wall and ceiling surfaces are likely to be plaster on timber lathing. These traditional plasters, whether lime or gypsum, are inherently resistant to spread of fire. However, the strength of such finishes is determined by the quality of the key between plaster and lath (or other substrate). When this is damaged through movement of the substrate or decay of the timber laths, the capacity of the finish to withstand fire is reduced. In a fire situation there is a risk that unstable plaster will collapse suddenly, exposing combustible material to fire. Thus, in the fire risk assessment of linings, the condition of the plaster and its substrate should be considered.

**2.5.3 Issues to be considered**

Issue	Risks to historic/traditional buildings
Internal linings	<ul style="list-style-type: none"> <li>• Some historic wall and ceiling linings may cause spread of fire and their removal or treatment can result in a significant loss of historic character and fabric.</li> <li>• Multiple layers of paint or other coverings may present a fire risk, but their indiscriminate removal may destroy a layer of historic importance.</li> </ul>

**2.5.4 Recommendations to meet the standard**

- a) Intumescent paints and varnishes are widely available in a variety of forms for the treatment of timber and there are many examples of these products being successfully used in historic buildings. Also, other treatments are available for other materials such as: lath and plaster; wallpaper, fabrics and drapes. However, expert advice should always be sought in these cases, so as to ensure any fire protection coating will not damage any base material that which requires preservation.
- b) Following a full and detailed fire risk assessment, it may be possible to reduce or eliminate fire hazards to the extent that the possibility of internal linings becoming involved in fire, or consequently posing a hazard to persons in the building, is very limited. Should this be the case, it may be possible that, subject to the approval of authorities having jurisdiction, the linings in question may be left as they are. However, such a strategy will require good ongoing management in accordance with BS 5588 Part 12 and confidence that standards will

be maintained. Furthermore, such an arrangement should be communicated to the relevant fire and rescue service as it could affect safe access for fire-fighting, and may need recording on any operational/tactical risk plan for the building.

- c) The use of automatic fire suppression, particularly fire sprinklers with upward/sidewall sprinkler heads, can provide sufficient wall wetting to modify flame spread across many combustible surfaces. For further information see Section 2.15.

### 2.5.5 Related standards

Other related standards are:

- Standard 2.1. Compartmentation
- Standard 2.2. Separation
- Standard 2.9 Escape
- Standard 2.14 Fire service facilities
- Standard 2.15 Automatic life safety fire suppression systems

## 2.9. Escape

### Standard 2.9

Every *building* must be designed and *constructed* in such a way that in the event of an outbreak of fire within the *building*, the occupants, once alerted to the outbreak of the fire, are provided with the opportunity to escape from the *building*, before being affected by fire or smoke.

#### 2.9.1 Type of standard

##### *Mandatory standard*

In the case of *conversions*, the *building* as *converted* must meet the requirement of this standard.

#### 2.9.2 Commentary

Due to its mandatory status, this standard, whether applied to the conversion of domestic or non-domestic buildings, is likely to have a significant impact on the fabric and character of historic buildings. The standard will have an influence on the existing historic spatial arrangements within the building, the fire resistance requirements of elements forming escape routes and it could even affect the external envelope of the building, which, of course, should be avoided and only considered as a last resort.

If rigorously applied, many requirements may cause much that is of significance within the building to be lost and it is important that, to ensure both the conservation of the building and the safe escape of occupants, the guidance in the Building Standards Handbook is interpreted with sensitivity. Reference should be made to the Preface to fire standards in Part II, Section 2, Fire, of this Guide, where the adoption of a fire engineering approach to the conversion of historic buildings is suggested.

It is therefore recommended that, for all important historic buildings in which the internal fabric is essentially intact, fire engineering is included in the design of conversions and suitably qualified and experienced fire engineering specialists are appointed for this work. In some circumstances it may be the case that, even with fire engineering, the provision of safe escape cannot be achieved without significant loss of historic character. Where this is the case the suitability of the building for its intended change of use must be questioned. However, most buildings can be adapted successfully: there are many examples of Category A listed buildings being sympathetically converted to a new use while retaining their historic character.

However, it is possible that in many historic building conversions the nature, size and significance of the building – particularly of its internal fabric – will not warrant a full fire engineering approach. In such cases, the sympathetic alteration of the interior to improve its physical features for escape purposes, combined with elements of fire engineering – such as automatic fire detection – may provide a solution that meets the functional requirements of this standard.

By applying the guidance in BS 7974: 2001 or BS DD 9999: 2005 it may be possible, for example, to compensate for deficiencies in escape route travel distances and combustibility of materials by the use of automatic fire detection and suppression systems. These systems will provide early warning to occupants of the outbreak of a fire and rapid intervention to suppress the fire, both of which will allow time for safe escape. Implementing fire engineering provides the occupants with the opportunity to escape from the building before being affected by fire or smoke, which is the essential requirement of the standard.

Where conversion of a building is not constrained by internal planning, such as when there is nothing of historic value remaining within the external envelope, implementation of the detailed guidance in the Handbook on passive escape measures must be included within the design. Nevertheless, while escape routes and associated features should be in accordance with the standard, including combustibility requirements, the exits from the building may adversely affect the character of historic façades.

There are a number of specific issues where, in the implementation of the standard, there is the potential to increase the risk to the building. These are important because apparently simple alterations can be influential in loss of character. Section 2.9.3 below outlines the most common examples.

It should also be appreciated that over the years many historic buildings have been accepted with refuge spaces provided (eg on roofs and balconies) where people can wait, and where reliance has been placed upon rescue by the fire service. This practice is no longer acceptable and, in these cases, new arrangements will be required. Furthermore, means of escape for disabled persons should not rely upon fire service rescue, and proper facilities and procedures should in all cases be established in accordance with BS 5588 Part 8: 1999. Note: such spaces should not be confused with ‘temporary waiting spaces’ as defined by this standard.

### 2.9.3 Issues to be considered \*

Issue	Risks to historic/traditional buildings
1. Number of fire exits	<ul style="list-style-type: none"> <li>The provision of additional fire exits from non-domestic buildings can be damaging to internal spaces and to the external character of the building.</li> </ul>
2. Travel distance	<ul style="list-style-type: none"> <li>To adhere strictly to a maximum travel distance may cause alterations within the building that are disruptive to historic spaces.</li> </ul>
3. Escape windows (domestic buildings)	<ul style="list-style-type: none"> <li>The provision of an openable window large enough to escape through in upper storey apartments and houses may require alteration to historic windows.</li> <li>The minimum height of 1000mm above the floor of the openable part may also be difficult in some situations when a cill height has to be lowered.</li> </ul>
4. Headroom	<ul style="list-style-type: none"> <li>A headroom of 2m may be difficult to achieve in some attic conversions.</li> <li>A minimum clear headroom of 1.9m to a doorway in an escape route may be difficult to achieve in a historic doorway, and will usually mean alterations to the opening and to the door itself – historic doors and frames may be lost.</li> </ul>
5. Fire doors	<ul style="list-style-type: none"> <li>Doors to protected zones are required to be self-closing fire doors with at least <i>medium</i> fire resistance duration in non-domestic buildings and at least <i>short</i> fire resistance duration in domestic buildings. Providing even short fire resistance duration with a historic door may be impossible without significant changes to the character of the door.</li> </ul>
6. Locks	<ul style="list-style-type: none"> <li>Historic ironmongery eg locks, can greatly contribute to the character of the door. Types of hardware recommended in the Code of Practice of the Building Hardware Industry Federation (2000) <i>Hardware for Timber Fire Escape Doors</i> may not be compatible with the historic door.</li> </ul>
7. Temporary waiting spaces	<ul style="list-style-type: none"> <li>The formation of unobstructed temporary waiting spaces of not less than 700mm x 1200mm on every escape stair landing may be difficult to provide without alterations to existing spaces and fabric.</li> </ul>

\* The issues are drawn from the standards: some apply to all buildings, some to non-domestic only and some to domestic only.



8. Protected zones and protected enclosures	<ul style="list-style-type: none"> <li>• The need for the enclosing structure of a protected zone (part of the escape route) to have at least a medium fire resistance duration and any door in the enclosing structure to have at least short fire resistance duration may cause loss or alteration of historic finishes and doors.</li> <li>• Short fire resistance duration also applies to any door in a protected enclosure.</li> </ul>
9. Combustibility – escape stairs	<ul style="list-style-type: none"> <li>• The requirement for every part of an escape stair (including the landing) and the floor of a protected zone or protected lobby to be constructed on non-combustible material may be unacceptable where the escape stair is an important historic timber stair.</li> <li>• In a building where all the floors are timber, the construction of a non-combustible floor to a protected zone or lobby is likely to be damaging to historic fabric.</li> </ul>
10. Junctions	<ul style="list-style-type: none"> <li>• The need to ensure continuity of fire-stopping at junctions between escape routes and other parts of the building may require the removal of historic finishes.</li> </ul>
11. Direction of door openings (non-domestic buildings)	<ul style="list-style-type: none"> <li>• Where the occupant capacity is 10 or more for storage or factory buildings, or 60 or more for other buildings, doors across escape routes should open in the direction of travel. This can mean alteration to the door and to adjacent spaces.</li> </ul>
12. Signs and notices	<ul style="list-style-type: none"> <li>• Signs and notices can be obtrusive and not in keeping with the historic nature of the building.</li> </ul>

#### 2.9.4 Recommendations to meet the standard

##### 1. Fire risk assessments

Traditionally, prescriptive codes and guidance relating to means of escape has focused primarily upon evacuation times with commensurate rules on maximum travel distances. It is often these rules that will determine the location of staircases and final exits. In every case there will therefore be a need to carry out a full and detailed fire risk assessment in order to establish:

- all persons who may be at risk,
- the potential and inherent fire risks within the building,
- what control measures that may already exist and/or are reasonably expected to be within the building.

By establishing a more accurate assessment of the fire risks involved, efforts thereafter to reduce the fire risk classification can be consequently translated into longer travel distances – subject to ongoing good management in accordance with BS 5588 Part 12.

Similarly, with numbers of exits and exit widths, particularly in the larger public buildings used for assembly and entertainment, limiting the maximum numbers of persons within the building, or parts of the building, at any one time may be an acceptable alternative to installing new or wider exit doors and damaging historic structures. However, it should be emphasised that a restricted access strategy, while initially often considered an attractive proposition, is rarely seen as such a satisfactory solution in later years.

##### 2. Available safe egress time

When designing buildings for life safety, BS 7974 (together with its associated ‘Published Documents’) describes how the aim should be to ensure that the time available for escape, the available safe egress time (ASET) should be greater than the actual time needed to reach a place of relative safety ie required safe escape time (RSET). This can be demonstrated by:

- modelling fire and smoke development to determine the onset of untenable conditions for persons in a building (to determine ASET),
- calculating the total sum of the fire detection/alarm time, the recognition/response time, and the travel time to a place of safety (to determine RSET),
- comparing the results.

In some circumstances this exercise may prove that little, if anything, is required to be done to ensure adequate means of escape in an existing building – despite the fact that the building may not comply with the traditional prescriptive guidance.

In the majority of simpler buildings, it is appreciated that this approach is unnecessarily complex and time-consuming, and therefore the usual approach is to use accepted prescriptive standards as a yardstick and as a means of determining the adequacy of provisions. However, BS DD9999 (2005) can also provide a middle way by also allowing for more flexible design when additional fire precautions; such as automatic fire detection, fire sprinklers or smoke control systems etc, are installed. Making use of existing features, such as high ceilings that may act as large smoke reservoirs, can provide an acceptable level of safety for occupants, despite a lack of, or apparent weakness in, the existing means of escape facilities.

### 3. Active systems

Some advice already exists within the standard in relation to the provision of active systems of fire defence such as automatic fire detection and fire sprinklers and, where appropriate, weaknesses in means of escape might be adequately compensated for by increasing fire detection coverage and/or installing fire sprinklers.

### 4. Improvements to means of escape

Where improvements to the means of escape are still required, there are various ways that these can be achieved without unduly damaging the historic fabric of a building, such as:

- existing ground floor windows can sometimes, with care and diligence, be converted to suitable final exit doors that are in keeping with the building's façade;



- staircases can be enclosed by the careful introduction of new doors and screens or, if the building is devoid of high fire loads and smoke is the principal concern, lightweight fire screens and shutters can be installed: these can be particularly useful across wide and/or tall openings, such as at the head of large accommodation staircases;
- minor improvements to existing separating walls can convert them into what can be considered compartment walls thus reducing travel distances;
- existing walls, doors and floors can be upgraded causing minimal disruption (see Section 2.1.).

### 5. Ironmongery and signage

Deficiencies in such features as locks on doors, low headroom, signs and notices etc, can sometimes be compensated for with the provision of enhanced supervision and stewarding, particularly in public buildings such as museums and galleries. Hold-open devices on inward opening doors across escape routes may be considered, even when such doors are required to be fire resisting and self closing. This is because it might not be necessary for all fire-resisting doors to close immediately upon actuation of the fire alarm, with some operating on a delay or locally placed smoke detectors. All of these solutions will clearly rely upon good levels of supervision and management and approval of authorities having jurisdiction, particularly the local fire authority. Further information on doors and door devices can be found in Historic Scotland TAN 23, 2005, *Fire safety management in heritage buildings*.

*Illus 2.9.1 Hold open device on historic paneled door within an escape route (Photo: D Urquhart)*

### 2.9.5 Related standards

Other related standards are:

- Standard 1.1 Structure
- Standard 2.2 Separation
- Standard 2.3 Structural protection
- Standard 2.4 Cavities
- Standard 2.5 Internal linings
- Standard 2.10 Escape lighting
- Standard 2.11 Communications
- Standard 3.16 Natural lighting
- Standard 4.1 Access to buildings
- Standard 4.2 Access within buildings
- Standard 4.3 Stairs and ramps
- Standard 4.8 Danger from accidents (safe cleaning of windows)
- Standard 5.1 Resistance to sound transmission

## 2.10 Escape lighting

### Standard 2.10

Every *building* must be designed and *constructed* in such a way that in the event of an outbreak of fire within the *building*, illumination is provided to assist in escape.

### 2.10.1 Type of standard

#### *Mandatory standard*

In the case of *conversions*, the *building* as *converted* must meet the requirement of this standard.

### 2.10.2 Commentary

While the full implementation of this standard is essential, the introduction of escape route lighting and emergency lighting into a historic building can be dealt with in a way that causes minimum disturbance to both the aesthetics and fabric of the building. However, unsympathetic installations, which are introduced without regard to historic character, must be avoided. For example, the use of intrusive bulkhead fittings and surface mounted, fire-protected cables are unlikely to be acceptable in most situations. The use of self-contained emergency luminaires may be more easily accommodated within an existing building than the installation of a protected circuit to the existing lighting system.

### 2.10.3 Issues to be considered

Issue	Risks to historic/traditional buildings
Location of fixtures and fittings and routing of cables.	<ul style="list-style-type: none"> <li>• Aesthetic damage to historic character,</li> <li>• Disruption of finishes.</li> </ul>

### 2.10.4 Recommendations to meet the standard

This standard makes a distinction between ‘escape route lighting’ that may be by a protected circuit, and ‘emergency lighting’, which requires an alternative power supply. Generally the technical requirements for escape route lighting or emergency lighting in different building types are well covered in publications referred to within the standard. In particular, BS 5266 Parts 1 (2005) and 7 (1999) give details on the requirements for most building types.

A protected circuit can be created by running a fire-protected power supply from a distribution board near the origin of the electrical supply for the building. Suitable materials for this are Mineral Insulated Copper Sheathed (MICS) cables or fire-protected soft bodied cables such as Firetuf or FP200.

If emergency lighting is required, the two main generic options are central battery systems or self-contained emergency luminaires. Central battery systems are those in which emergency luminaires, located in different parts of the building, are supplied by a central battery power source via fire-protected cables. Local relays, usually positioned at the distribution board supplying the lighting circuits, switch the emergency luminaires on in the event of a power failure in any given lighting circuit. Self-contained emergency luminaires contain a battery pack and charging feed within the luminaire. If the control equipment within the battery pack senses a loss of power to the permanent live charging feed then the luminaire will be switched on.

These two systems have relative advantages and disadvantages. The central battery system is more suited to larger buildings whereas the self-contained solution is suited to smaller buildings. These relative advantages apply also to installation and maintenance costs. The luminaires associated with central battery systems tend to be more discreet and compact than those for self-contained systems. Both systems can be arranged to operate certain luminaires in the general lighting scheme as emergency luminaires. However, arranging this is more straightforward and usually more cost effective with the self-contained option than with the central battery system.

Emergency lighting must be functional, but great care is also required when designing an installation for a historic building because the aesthetic impact of the luminaires can be significant.



A further option for emergency lighting that can produce more sympathetic solutions is a hybrid system, which utilises inverter and battery packs located near to the emergency luminaires, and connected to these via fire protected cable. The luminaires are switched on when the charging feed to the battery pack is interrupted (as in the self-contained system). This arrangement can be used to power a single lamp in a chandelier, for instance, and is particularly useful when aesthetic considerations make it difficult to utilise more standard emergency lighting solutions.

### 2.10.5 Related standards

Other related standards are:

- Standard 2.9 Escape
- Standard 6.5 Artificial and display lighting

*Illus 2.10.1 Emergency lighting installation in a listed Category A building (Photo: S Brown).*

## 2.11 Communication

### Standard 2.11

Every *building* must be designed and *constructed* in such a way that in the event of an outbreak of fire within the *building*, the occupants are alerted to the outbreak of fire.

#### Limitation

This standard applies only to a building which:

- a) is a *dwelling*;
- b) is a *residential building*; or
- c) is an enclosed shopping centre.

### 2.11.1 Type of standard

#### Mandatory standard

In the case of *conversions*, the *building as converted* must meet the requirement of this standard.

### 2.11.2 Commentary

Communication of fire warning is an essential standard for dwellings, residential buildings and enclosed shopping centres. However, their use may be appropriate for other types of conversion where there may be a need to compensate for deficiencies in other areas of the fire standards.

Generally, the sympathetic installation of these systems in historic buildings can be achieved without significantly affecting its historic character. The standard promotes the use of permanent wiring to a circuit for smoke alarms and the technical handbooks state that '*smoke alarms may be interconnected by hard wiring on a single final circuit*'. However, there is a case in the conversion of a historic building for this to be replaced with a radio installation, and BS 5839 provides guidance for the design requirements of such a system. Radio installations reduce significantly the need to run cables within the construction and, when this is done during a conversion, the additional disruption will be minimal. Radio-linked components forming part of a BS 5839-1 fire alarm system all contain individual batteries. While this reduces cabling needed, the ongoing replacement of batteries over the life of the system will need to be properly costed and managed. This aspect should be given due consideration as part of the selection process. The following points should be noted:

- the smoke alarms are connected to the mains supply, and
- the radio-interlinking does not reduce the battery life of an alarm when the power is down,
- the local authority and fire authority should be satisfied that the potential for accidental false alarms has been managed.

### 2.11.3 Issues to be considered

Issue	Risks to historic/traditional buildings
Location of detection devices	<ul style="list-style-type: none"> <li>• Wired systems can be damaging to historic fabric</li> <li>• Detector heads can be disruptive to historic character of ceilings.</li> </ul>

### 2.11.4 Recommendations to meet the standard

The technical requirements for fire detection and alarm systems in different building types are well covered in publications referred to within the standard. In particular, BS 5839: 1995 Parts 1 and 6 give details on the requirements for non-domestic and domestic building types respectively.

Note that the standard differentiates between dwellings with no storey greater than 200m<sup>2</sup> and dwellings with a

storey greater than 200m<sup>2</sup>. In the former case, domestic smoke alarms that are self-contained may be mains powered with battery backup. Separate stand-alone domestic smoke alarms should be interconnected so that if one unit operates all others will also sound. In the latter case, a dwelling with any storey more than 200m<sup>2</sup> should be provided with a fire detection and alarm system designed and installed in accordance with BS 5839: 2002 Part 6.

The type of buildings for which automatic fire detection and alarm systems are required under the Building Regulations are very limited. However, it is often necessary to consider such systems for other reasons. This may be because the owner or occupier:

- requires to comply with fire safety legislation,
- requires asset protection or a system for insurance purposes, or
- requires a system as part of a fire engineering solution to compensate for a failure to comply with other fire safety guidance within the standards.

This third reason arises frequently in historic building conversions. ***The installation of an automatic fire detection and alarm system is generally the most practical way of overcoming difficulties in complying with normal requirements for escape routes, fire separation and the like.*** It should be noted that if the system is installed for this reason, it is usually necessary for the system to be of a high standard. Typically, it will be necessary to design the installation to an L1 (M) level of coverage and to make the installation fully addressable (ie so that individual detection devices can be uniquely identified at the fire alarm panels), so giving building occupiers and the fire fighters precise information about the areas of the building affected by fire.

The two main options for a fire detection system are:

- a) fully wired installations and
- b) wired installations with radio interlinking.

Radio interlinking is regarded as a reliable alternative to wired interlinking between detectors, and guidance is given in BS 5839 (Part 1 1995, Part 6 2002). The advantage of radio interlinking is that it is not necessary to run fire-protected cables to all the devices. These systems can therefore be installed with least disruption to the building fabric. This is particularly useful if little or no other work is planned for certain areas of the building. ***They can also be installed at a very early stage in a historic building conversion project and provide detection in the building during the contract – arguably the period of highest risk for the building.*** The advantage of a wired installation is usually lower cost, both in terms of initial and maintenance costs. The wiring of these systems is less disruptive if the installation is part of a general conversion or refurbishment project that requires other services to be installed at the same time.

A further option for some buildings with particularly fine, ornate ceiling finishes may be an aspirating smoke detection system. Sometimes it would be regarded as difficult to accept the installation of a normal detector head in such ceilings. Aspirating systems involve running lengths of pipe to small sampling points, which are generally only around 8mm in diameter. The holes for these sampling points must be located in compliance with the same rules as for smoke detectors. However, it is usually possible to do this while also positioning the holes in a feature of the plasterwork that renders them practically invisible. These aspirating systems are usually integrated into a system with discreet detection devices so that they, in effect, behave as detectors in the larger installation. They do, however, have disadvantages:

- they are generally significantly more expensive than point detectors and
- they are more limited in the addressable information that they can provide to the central alarm panel.

Even where the installation covers several zones, they often need to cover more than one room per zone to be cost effective (unless the rooms are very large), and so the grouping of rooms would require to be agreed with the verifying authority.



*Illus 2.11.1 Installation of an aspirating smoke detector system in a ceiling void. Shown is the main plastic air pipe with an 8mm diameter tube from it to go through an 8mm hole in the roof boarding (Photo: S Brown).*

### **2.11.5 Related standards**

Other related standards are:

- Standard 2.1 Compartmentation
- Standard 2.2 Separation
- Standard 2.3 Structural protection
- Standard 2.9 Escape



*Illus 2.11.2 Very discreet smoke detector set into historic ceiling. The detector head is located to the left of the ceiling rose (Photo: I Gough).*

## 2.12 Fire service access

### Standard 2.12

Every *building* must be accessible to fire appliances and fire service personnel.

#### 2.12.1 Type of standard

##### *Reasonably practicable standard*

Every *conversion*, to which these regulations apply, must be improved to as close to the requirement of the standard as is *reasonably practicable*, and in no case be worse than before the *conversion*.

#### 2.12.2 Commentary

Generally, fire-fighting is carried out within a building utilising many of the normal features that already exist, such as access roads and driveways, entrance doors and exits, internal stairways and exterior windows etc. However, from time to time, additional arrangements for fire fighters, their vehicles and appliances should be made.

As this is a standard that requires improvement to as close as is reasonably practicable, some work may not be undertaken where it is not seen as reasonable or practicable, but compensatory measures should be offered where access cannot comply.

Access from public roads to the exterior perimeter of a building must be available for both pumping and sometimes high-reach fire appliances, in order that fire-fighting resources can be brought close enough for effective use. The extent to which access is required is dependant on the size and use of the building. However, in addition, consideration should always be given not only to the height and width of vehicles, but also to axle weights and the working spaces required around them. This is particularly so, for example, with the jacking points of turntable ladders and hydraulic platforms.

As fire appliance design and specifications can vary (sometimes even within a fire authority and from the same manufacturer), the relevant fire and rescue service should always be consulted regarding:

- a) The vehicles and appliances that would be expected to be deployed;
- b) The tactical fire-fighting plans (if any) that are in place for adoption by attending fire crews; and
- c) The water supplies considered necessary to mount an effective fire-fighting attack.

This can reveal both weaknesses and strengths not only in the existing physical features of the building's fire defences, but also in the emergency plans that may already be established to deal with an unwanted fire. Such a meeting with the fire and rescue service can also confirm or correct perceptions about what measures would, in reality, be taken to tackle an outbreak of fire in any particular building and thus focus minds and resources effectively and efficiently.

Notwithstanding the guidance that may be contained in 'operational tactical plans' for a specific building, access into any building will only be made following a 'dynamic risk assessment' by the fire and rescue service officer in charge. This will take into account the size and complexity of the building together with unusual features that may be present and the features that may aid or hinder fire fighting. In most buildings the combination of access facilities offered by the normal means of escape, and the ability to work from ladders and appliances on the perimeter, will generally be adequate without special internal arrangements. However, in tall buildings and buildings with deep basements, special access facilities may be required.

Further guidance is contained in BS 5588 Part 5: 2004 *Fire precautions in the design, construction and use of buildings Part 5: Access and facilities for fire fighting*.



**2.12.3 Issues to be considered**

Issue	Risks to historic/traditional buildings
1. Access for vehicles and fire service personnel	<ul style="list-style-type: none"> <li>• Existing roads and driveways may not be suitable for vehicle weights and/or dimensions and only allow for limited access to a building’s footprint. Their alteration may affect historic character and setting.</li> <li>• Hard standing may be lacking or very limited. This can be a particularly serious problem in areas that suffer from poor drainage, as fire-fighting operations can result in large quantities of water being pumped or transported around a site, which may damage historic features.</li> <li>• Narrow and/or low-height gateways and arches, trees and vegetation may restrict vehicle access routes. Turning circles may not be available at the end of narrow driveways. These features may be protected by listed building legislation or tree preservation orders.</li> <li>• Safe working areas for fire appliances may sometimes be inhibited by being too close to buildings (in case of structural collapse), restricted by overhead cables and remote from water supply.</li> </ul>



*Illus 2.12.1 Improvement to fire service access at Duff House. A hard standing and turning area for fire service vehicles has been formed using ‘Grass-crete’ to reduce impact on the historic landscape. (Photo: D Urquhart).*

**2.12.4 Recommendations to meet the standard**

There are a number of issues that should be considered when implementing this standard:

1. In the case of a listed building, the listing applies to not just the building but, as a general rule, to all buildings within the curtilage, even if they are not individually listed. Listing often specifically includes boundary walls, gateways and similar structures. Any proposed changes to improve fire service access to structures within the curtilage, would therefore require listed building consent.
2. Access to historic buildings was generally not designed with fire service access in mind and, as a result, existing roads, hard standings, vehicle turning circles and reversing distances may not comply with the standard. However, in many cases, the original access will have been adapted over the years to suit the changing access needs of the building, and the original, historic surfaces may have been destroyed or buried under new surfaces. In such cases, or where the character of the site will not be adversely affected, fire service access

should be improved to as close to the requirements of the standard as is possible. Where changes are made to access, care should be taken to not disturb hidden archaeology.

3. Where, without unacceptable damage to historic character, it is not possible to alter fire service access to meet the needs of the standard, the introduction of the following measures may help to compensate for deficiencies in fire service access:

- automatic fire suppression may be utilised to compensate for poor fire appliance access, which may reduce the intensity and spread of fire, or even extinguish the fire, and give more time for the fire service to gain access to the fire;
- additional fire compartmentation and/or increased periods of fire resistance may delay fire growth and spread, whilst at the same time providing opportunities for securing better fire-fighting bridgeheads;
- good management with well established and rehearsed emergency plans, together with the preparation of 'emergency packs' (see BS 5588-12: 2004) for attending fire crews.

#### **2.12.5 Related standards**

Other related standards are:

- Standard 2.1 Compartmentation
- Standard 2.3 Structural protection
- Standard 2.13 Fire service water supply
- Standard 2.14 Fire service facilities
- Standard 2.15 Automatic life safety fire suppression systems
- Standard 4.1 Access to buildings.

### **2.13. Fire service water supply**

#### **Standard 2.13**

Every *building* must be provided with a water supply for use by the fire service.

#### **2.13.1 Type of standard**

##### ***Mandatory standard***

In the case of *conversions* the *building as converted* must meet the requirement of this standard.

#### **2.13.2 Commentary**

Under the provisions of Fire (Scotland) Act 2005, it is the duty of the relevant fire authority to '*take all reasonable measures for securing the supply of an adequate supply of water, and for ensuring that it will be available for use, in case of fire*'. If the supply is inadequate, the fire authority may enter into an agreement with either a water undertaker or '*any persons other than the statutory water undertakers*' for the provision of additional supplies. It should be noted that the fire authority cannot require those 'other persons' to provide additional supplies.

Water for fire fighting can be supplied in three ways:

- a) Carried by fire and rescue service vehicles: pumping appliances and water carriers.
- b) Available from either public or private water mains.
- c) Available from either 'open water' or static tanks.

In the vast majority of cases, unless a fire is very small and can be tackled successfully with a fire extinguisher, water from a fire service pumping appliance (sometimes called a water tender) will be used to fight the fire. This is sometimes referred to by fire-fighters as the ‘original’ supply.

Whilst fire and rescue service pumps can vary as to specification and design, they typically carry between 1000 litres and 2000 litres of water. This water is delivered via either high- pressure hose reels or lay-flat hoses, of either 44mm or 70mm diameter (however, in some parts of the UK, larger diameter lay-flat hoses are being introduced specifically for water relay purposes and will invariably be carried on an appliance called a ‘hose layer’).

Water carriers can carry between 4,500 litres and 20,000 litres and may also carry dams and associated equipment. A water carrier is always used in conjunction with a pumping appliance.

Water for fire fighting, other than the original supply, is primarily extracted via fire hydrants that are permanently fixed to the mains. All hydrants in the UK should comply with the requirements of British Standard 750: 1984, which requires that they be capable of delivering not less than 2000 litres per minute at a constant pressure of 1.7 bar at the hydrant inlet, with their location marked in accordance with British Standard 3251: 1976 (1993). Fire hydrants may be above ground, as is common in the USA, and are called ‘pillar’ (or sometimes ‘post’) hydrants; or below ground, as is more common in the UK. For historic building locations, below ground hydrants are clearly preferable.

The UK Home Office Fire Service Manual 2001 7 recommends that hydrants be placed at intervals of between 90 and 180 metres except in the case of high risk and rural areas. In high-risk areas it is common practice for hydrants to be placed so that they are not more than 18 metres away from the entry to any building and not more than 150 metres apart. In rural areas, hydrants may be spaced so that one is near an isolated property.

Hydrants are a most effective means of supplying water for fire-fighting; however, they are costly and in many cases the potential costs of installation can outweigh the benefits – especially where there are poor pressures and flows within the water mains themselves. In these circumstances fire authorities will seek to make use of open water, or water from static tanks.

Open water includes rivers, lochs, swimming pools and even the sea. Static tanks may include underground wells or above ground tanks specifically provided for such purposes (as was common during the Second World War in many UK towns and cities). In some sensitive locations, the installation of an above-ground tank may adversely affect the setting of the historic building.

A fire-fighting pump will have the ability to deliver water under positive pressure through hoses, but will also be able to draw water using negative pressure. In this case, a ‘hard suction’ hose is necessary to withstand the external atmospheric pressure acting upon it and, therefore, not collapse. However, one drawback with this method of obtaining water is that it is hydraulically very inefficient. It is essential that the pump be placed as close to the surface of the water as possible and, in any event, at a distance of not more than 8 metres. This can cause difficulties particularly when attempting to pump from bridges or deep wells.

Provided a fire pump can be made to work, these sources of water can be invaluable. Water can then be transported over considerable distances by either relaying water through hoses (sometimes with intermediary booster pumps) or by shuttle, utilising additional fire service pumping appliances.

Further guidance is contained in: BS 5588 Part 5: 2004 *Fire precautions in the design, construction and use of buildings Part 5: Access and facilities for fire fighting*.

### 2.13.3 Issues to be considered

Issue	Risks to historic/traditional buildings
1. Water hydrants	<ul style="list-style-type: none"> <li>• Installing new hydrants and upgrading existing water mains can damage historic landscapes and built features, and may disturb buried archaeology.</li> </ul>
2. Alternative water supplies	<ul style="list-style-type: none"> <li>• Provision of suitable hard standing adjacent to open water and not more than 8 metres from the surface of the water may be difficult to achieve without disturbing the site or the historic building itself.</li> <li>• The installation of above-ground water storage tanks can be visually intrusive within a historic site.</li> </ul>

### 2.13.4 Recommendations to meet the standard

Where, without unacceptable damage to the character and setting of a historic building, it is not possible to improve water supplies for fire-fighting and to meet the needs of the standard, the introduction of the following measures may help to compensate for deficiencies.

- a) In certain cases, the provision of a 'dry' fire main may enable water to be pumped remotely to a hydrant or hydrants close to and around the building, in order to supplement the water supplies carried on fire service pumps. Polyethylene piping is available and now approved (Factory Mutual) for underground fire protection services, and may provide a convenient alternative to traditional materials.
- b) Means for damming small burns quickly such as sluice gates or similar, together with facilities to enable light portable pumps to be used and transported on 4 x 4 vehicles along existing tracks.
- c) Provision of 'bridge doors' in the parapet of a bridge may enable a suction hose to reach the surface of a river or stream from a fire pump's nearest access point and without kinking the hose.
- d) Where above-ground tanks are required, the site must be carefully considered so that, while accommodating the requirements for fire service water supply as far as possible, careful design of the landscaping of the site reduces the impact of the tank on the historic environment.
- e) Automatic fire suppression may be utilised to compensate for poor water supplies by reducing the intensity and spread of fire (or even extinguish it entirely) and giving more time for fire-fighters to gain access to the fire and extinguish it with the original supply carried on pumping appliances.



*Illus 2.13.1 Landscaped underground storage tank with minimal intrusion into historic landscape which could have been improved with more careful detailing of intrusions. (Photo: D Urquhart).*

### 2.13.5 Related standards

Other related standards are:

- Standard 2.1 Compartmentation
- Standard 2.3 Structural protection
- Standard 2.12 Fire service access
- Standard 2.14 Fire service facilities
- Standard 2.15 Automatic life safety fire suppression systems
- Standard 4.1 Access to buildings.

## 2.14 Fire service facilities

### Standard 2.14

Every *building* must be designed and *constructed* in such a way that facilities are provided to assist fire-fighting or rescue operations.

#### 2.14.1 Type of standard

##### **Mandatory standard**

In the case of *conversions*, the *building as converted* must meet the requirement of this standard.

#### 2.14.2 Commentary

*A fireman, to be successful, must enter buildings; he must get in below, above, on every side, from opposite houses, over back walls, over side walls, through panels of doors, through windows, through loopholes, through skylights, through holes cut by himself in the gates, the walls, the roof; he must know how to reach the attic from the basement by ladders placed on half burned stairs, and the basement from the attic by rope made fast on a chimney. His whole success depends on his getting in and remaining there and he must always carry his appliances with him, as without them he is of no use.*

So wrote Sir Eyre Massey Shaw in his book, *Fires and Fire Brigades* in 1884. Whilst some of the techniques suggested would probably not find favour with more safety conscious C21 fire-fighters, the general principles proposed by Shaw, over a century ago, are still valid today.

While ‘defensive’ fire-fighting is usually practised outside a building, ‘offensive’ fire-fighting is carried out within a building, utilising many of the normal features that already exist there. Fire-fighters will therefore gain access via entrances and exit doors and will use corridors and stairways provided for the occupants’ day-to-day use.

Occasionally they will gain access to upper floors from ladders pitched outside windows, thereby bypassing stairways that may have been affected by a fire. This has the advantage of requiring shorter hose lines into a fire zone and a ready means of ventilating heat and smoke to open air. It also provides a quick and certain exit route!

However, with tall buildings beyond the reach of fire and rescue service extension ladders, most of which can only reach a maximum height of 11 metres, these activities can only take place from within the building. Similarly, with deep basements, fire-fighters must descend into what may in effect become a chimney, as the products of combustion will rise up, making this type of fire particularly difficult to deal with. Indeed, basement fires are potentially the most dangerous of all fires to fight offensively as they can place great demands on the physical capabilities of individual fire-fighters. Both of these types of fires have been the feature of recent research carried out by the The Building Disaster Assessment Group 2004 for the Office of the Deputy Prime Minister.

In each of these circumstances additional integral measures are required in a building, both to protect fire-fighters and to reduce the burdens placed upon them. This includes fire-fighting water mains, considered necessary to alleviate the need to run out large amounts of hose and manoeuvre it through a building. For safety reasons hose lines are nearly always charged before being taken into a building on fire; a fully charged hose is very heavy and less flexible than might be imagined; therefore, permanently fixed mains may save time and manpower. It should also be noted that such mains have the potential advantage of protecting a building from considerable damage, such as that which might be caused by burst hoses outside the room of fire origin. However, this is always incumbent upon the main being properly maintained and periodically inspected.

Fire-fighting mains may be either:

- a) Rising
- b) Falling
- c) Horizontal

In practice, fire-fighting mains are generally ‘dry’ or ‘wet risers’ installed in accordance with BS 5306: Part 1 (dry being mains filled by the fire and rescue service on arrival at an incident; ‘wet’ being mains permanently filled with water).

In larger historic buildings it is not uncommon to find dry riser fire-fighting mains. Unfortunately, they (or more specifically the landing valves), are often not enclosed within a fire resisting enclosure where a fire-fighting 'bridgehead' may be established. A fire-fighting bridgehead may be described as *'part of a building, usually the floor below the fire floor (the floor above in the case of basements), from which fire-fighting teams can be safely committed to attack a fire.'*

In tall buildings (with topmost storey height more than 18m) or buildings with deep basements it is desirable to establish such bridgeheads within staircases and in these circumstances a 'fire-fighting shaft' is formed. Fire-fighting shafts must necessarily be well protected from the effects of any fire by being enclosed within a long (two hour minimum) fire resistance duration structure accessed via a self closing medium fire resistance duration door (FD 60S); the stairwell being further protected by another short fire resistance duration door (FD 30S) thus creating a 'fire-fighting lobby'.

In buildings with a top storey higher than 18 metres, or where a basement is deeper than 10 metres, this shaft should include a lift, specially designed and installed so that fire-fighters may safely use it for transportation of personnel and equipment. A word of caution is appropriate here, particularly in the case of historic buildings that may already have what appears to be a suitable lift installed, as there are many cases of lifts previously accepted for fire brigade use which on closer examination do not satisfy the current safety requirements contained within BS EN 81-1 or BS EN 81-2

However, on a more positive note, it is becoming increasingly acceptable to utilise fire-fighting lifts for evacuating disabled persons and therefore any expenditure in this area may have significant additional benefits in relation to Standard 2.9, Escape.

A fire-fighting bridgehead must be kept free from smoke and so it is vitally important that there are facilities to ventilate any smoke that might seep into the fire-fighting shaft – particularly the stairwell, which will probably also be required as a means of escape. Furthermore, due to the difficulty of removing heat and smoke naturally from basements, mechanical extract systems may be necessary.

The purpose of fire ventilation, as distinct from normal ventilation, is threefold:

- a) to facilitate fire-fighting,
- b) to prevent the spread of fire,
- c) to reduce damage by heat and smoke.

It must be recognised however, that whilst a considerable amount of research has taken place in the field of fire and smoke ventilation, this is a very complex subject. Moreover, it is perhaps fair to say that building standards are not necessarily in step with modern day fire-fighting tactics, as revealed by the work of the Building Disaster Assessment Group. The standards themselves may therefore be inappropriate and early consultation with the statutory bodies and a competent fire engineer will be essential.

A traditional building typically contains a main access staircase that is a central and important feature of the building and from which rooms open directly on to unprotected landings. The construction of a fire-fighting stair – or fire-fighting shaft in taller buildings – to enclose such a staircase and designed to comply with the recommendations of the standard has the potential to cause significant damage to the character of the building. A major challenge is



*Illus 2.14.1 Dry riser inlet located to reduce impact on historic character by locating inlet valves beneath cast iron cover in footpath (Photograph from TAN 28: Paul Beaton, Historic Scotland).*

thus presented to designers to meet the requirements of the standard by other means.

Further guidance is contained BS 5588 Part 5: 2004 'Fire precautions in the design, construction and use of buildings Part 5: Access and facilities for fire fighting.'

**2.14.3 Issues to be considered**

Issue	Risks to historic/traditional buildings
1. Internal mains	• Difficult to install new mains without damaging historic features.
2. Fire-fighting lobbies and shafts	• The creation of fire resisting enclosures to the required standard and/or construction of lobbies may damage historic features.
3. Fire-fighting lifts	• Upgrading existing lifts may prove uneconomic.
4. Ventilation of heat and smoke	• Providing openable lights/ventilators in fire-fighting staircases may damage the external fabric of a building. • Roof mounted fire ventilators may also damage historic roofing features.

**2.14.4 Recommendations to meet the standard**

There are a number of issues that should be considered when implementing this standard:

1. For a low rise building an unvented lobby may be used. If the stair is on an external wall, 1.0m<sup>2</sup> of ventilation should be provided, which could be an openable window. Openable vents should be outward opening, but not top hung, be able to open to a minimum of 30 degrees and be clearly identifiable and accessible. They should be fitted with simple lever handles, rotary devices or locks that can be operated by the fire service.
2. Consideration ought to be given to the use of CPVC pipework for the provision of both dry and wet rising fire mains. Because of its lightness and simple jointing methods, this material is much easier to use and may be less damaging to historic structures than steel pipes. However, as the use of CPVC is outside of the specifications laid down in BS 5306 Part 1 1976, this approach must always be carefully 'risk assessed' and full approval of the authorities having jurisdiction, together with the building's insurer, is essential.

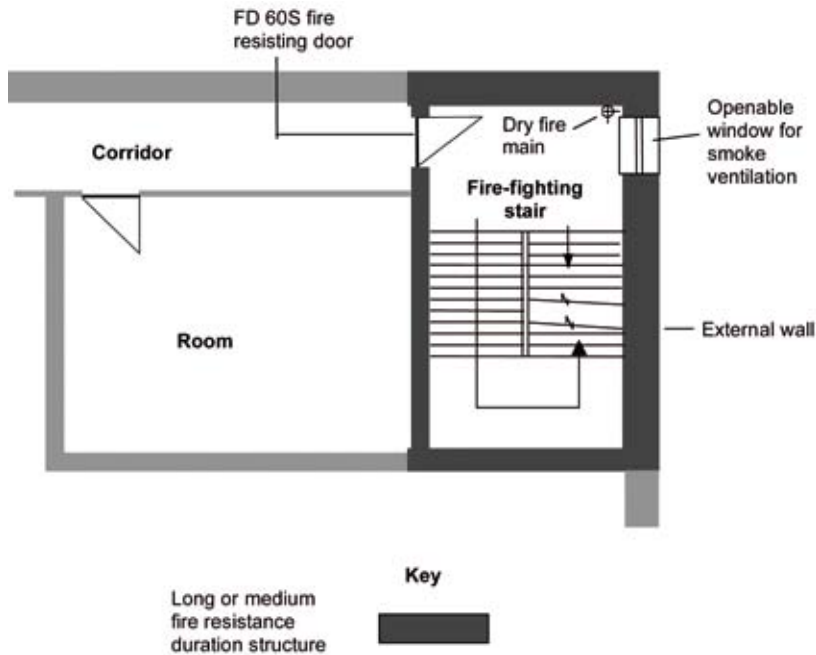

Illus 2.14.2 Fire-fighting stair for a building with a topmost storey height between 7.5m and 18m.

3. Where, without unacceptable damage to historic character, it is not possible to alter or improve facilities to aid fire service access and to meet the needs of the standard, the introduction of the following measures may help to compensate for deficiencies:

- a) Automatic fire suppression may be utilised to compensate for poor facilities to aid fire-fighter access by reducing the intensity and spread of fire (or even extinguish it entirely) and so give more time for the fire service to safely gain access to the fire.
- b) Additional fire compartmentation and/or increased periods of fire resistance may delay fire growth and spread, whilst at the same time providing opportunities for securing fire-fighting bridgeheads.
- c) Reduction in the quantity of combustible materials, combined with good site management in accordance with BS 5588-12: 2004, may compensate for poor facilities for ventilating fire compartments.

#### **2.14.5 Related standards**

Other related standards are:

- Standard 2.1 Compartmentation
- Standard 2.2 Separation
- Standard 2.3 Structural protection
- Standard 2.4 Cavities
- Standard 2.9 Escape
- Standard 2.11 Communication
- Standard 2.12 Fire service access
- Standard 2.13 Fire service water supply
- Standard 2.15 Automatic life safety fire suppression systems
- Standard 4.1 Access to buildings

### **2.15 Automatic life safety fire suppression systems**

#### **Standard 2.15**

Every *building* must be designed and *constructed* in such a way that, in the event of an outbreak of fire within the *building*, fire and smoke will be inhibited from spreading through the *building* by the operation of an automatic life safety fire suppression system.

#### Limitation

This standard applies only to a *building* which:

- a) is an enclosed shopping centre;
- b) is a *residential care building*;
- c) is a *high rise domestic building*; or
- d) (d) forms the whole or part of a *sheltered housing complex*



### 2.15.1 Type of standard

#### **Mandatory standard**

In the case of conversions, the *building as converted* must meet the requirement of this standard.

#### 2.15.2 Commentary

Automatic fire suppression systems have the ability to not only detect and signal the outbreak of a fire but also to physically fight it. There are a number of different automatic fire suppression systems available and the suitability of each type of system will depend on a range of factors, including the type of fire likely to be encountered in the protected space. Historic Scotland Technical Advice Notes TAN 11 and TAN 28 provide detailed information on the various systems and their use within historic buildings.

**However, the standard requires that automatic life safety fire suppression systems be installed to DD 251:2000 (now BS 9251: 2005) and some of these different systems may not comply with this requirement.**

The technical requirements for fire suppression systems in different building types are well covered in publications referred to within the standard and BS 9251: 2005 gives guidance on the requirements for installations in sheltered housing, residential care homes and high rise domestic buildings, whilst BS 5306 Part 2 and BS EN 12845 together with the LPC publication *Rules for Automatic Sprinkler Installations* (1994), which gives details relating to various non-domestic applications.

The types of buildings for which automatic fire suppression systems are required under the building regulations are very limited. However, it is often necessary to consider such systems for other reasons. This may be because the owner or occupier requires a system for insurance purposes, or requires a system as part of a fire engineering solution to compensate for a failure to comply with other fire safety guidance within the standards. This second reason arises frequently in historic building conversions.

The installation of an automatic fire suppression system is sometimes a practical way of overcoming difficulties in complying with normal requirements for escape routes, fire separation and the like. It should be noted that, if the system is installed for this reason, it might be necessary to make a detailed fire engineering case to show how the suppression system is able to provide the same level of protection to building occupiers as the normal provisions of the standards.

In the installation of an automatic fire suppression system into a historic building, the risks posed to its fabric and character by the installation must be considered. Any changes to a listed building must not only satisfy fire protection needs, but also the legislation in respect of listed building consent. However, the process of converting a building does provide the opportunity to install a fire suppression system along with other work. There will inevitably be some opening up, which can be part of a planned process where the necessary pipe work and other features can be hidden from view, resulting in minimum disruption to surface finishes. In the case of a badly dilapidated building, the installation of an automatic fire suppression system will be more easily accommodated.

A further consideration is the provision of an adequate supply of water at the required pressure. If mains water is not available, or the pressure inadequate, there will be a requirement for quite large water storage facilities, which may be very disruptive to the building if positioned internally. External storage tanks may be difficult to locate in a position that does not impact on the historic character of the property.

Sprinklers required for life safety must be of the 'wet pipe' variety ie the pipework is permanently charged with water. Therefore, and where appropriate, precautions against freezing should always be taken.

#### 2.15.3 Issues to be considered

Issue	Risks to historic/traditional buildings
System installation	<ul style="list-style-type: none"> <li>• Installation of pipes and related fittings may be damaging to historic character and fabric if poorly planned.</li> <li>• Sprinkler heads and smoke/fire detectors can be unacceptably intrusive within important historic spaces.</li> <li>• Installation of pumps and water storage within buildings may require significant structural and spatial alterations, which may be unacceptable.</li> </ul>

### **2.15.4 Recommendations to meet the standard**

#### *Sprinkler systems*

Two main options for sprinkler installations are direct mains-fed systems and systems that have water storage and pumps.

- a) The mains-fed system is significantly less expensive and less complex than the pumped system and requires less space; however, there are limitations on its use. Specifically, the mains water pressure and flow rate in the area must be such that the water supply can serve the sprinklers together with a degree of confidence in the continuity and reliability of the service. Scottish Water must be consulted on this and flow rates and pressures should be measured near the point at which it is intended to make the connection. Water pressures and available flow rates can vary from time to time depending upon demands on the network and this should be taken into consideration. To comply with the guidance on design of these systems the sprinkler installation must be capable of operating correctly at the lowest anticipated supply pressure.
- b) If the mains water supply is inadequate, or does not exist (eg in a rural location where the building is served by a private water supply), then it may be necessary to use a system with a storage tank and pumps. Often a standby power supply or a pump driven directly by a diesel (or similar) engine is required for these systems so that the pumps can operate during a power failure. These requirements can become quite onerous in terms of cost and the space required to house the equipment, which is often problematic in a historic building. It is possible to locate the central equipment (tank, pumps, standby power facility etc) outside of the premises served by the installation (in an out-building for instance or underground) and pipe the sprinkler water into the building.

Running sprinkler pipework through a historic building and locating the sprinkler heads can be problematic too. Pipework is typically quite large (in the order of 100mm diameter in certain parts of the installation). Finding vertical and horizontal routes for such large pipes in traditionally constructed buildings is usually difficult. Possible approaches to resolving the problems can include the following:

- a) The use of modern CPVC pipework can alleviate many of the difficulties of installation and may be less damaging to historic structures. Unfortunately, being less rigid than steel, it may well require more support.
- b) Flexible connections for fire sprinklers are now available and can enable connections to be made in difficult locations without damaging existing structures.
- c) The problem of pipe size can be eased by utilising a network design for the distribution rather than a simple root and branch type design. A network design allows parallel routes for water to flow to a given sprinkler head, so reducing the size of each individual pipe.
- d) Having high pressures available also helps, as the higher the pressure the smaller the pipes can be to carry the same quantity of water. The available pressures can be adjusted when using a pumped system, but if using a direct main supplied installation, pressure in the system is governed by the reliable pressure at the main.
- e) Changing a building or its structure to accommodate a sprinkler system should be considered only as a last resort. The system should be designed to reflect the construction and spatial arrangement of the building and pipework should be routed, wherever possible, through existing voids, ducts, spaces, such as 'dumb waiters', old chimneys and disused pipe ducts.

The location of sprinkler heads may require particularly careful consideration in historic buildings because of the aesthetic impact and/or the interference with historic fabric. Ornate ceilings present a particular problem since inappropriately located heads may damage plasterwork or detract from the enjoyment of the ceiling. It will be necessary for the sprinkler system designer to take special care to consider the style and location of heads to minimise the intrusion of the system while still meeting the functional requirements for coverage of the heads within the room.

The use of recessed and/or concealed sprinkler heads (rather than the traditional pendant type of fire sprinkler head) will be visually less obtrusive and, whilst care must always be taken to ensure fire sprinkler heads are not painted, they can be supplied in colours to suit.

Generally the design of these systems will have to be carried out by a suitably qualified engineer or a specialist contractor with in-house design facilities. In either case, the particular demands of historic buildings should be



*Illus 2.15.1 Discreet sprinkler head located behind a colour-matched circular cover in ornate ceilings at Duff House (Photo: D Urquhart).*



*Figure 2.15.2 Sidewall sprinkler head above a cornice in Duff House. (Photo: D Urquhart).*

made clear to them at the outset, and enough time allocated to the design and installation processes, which are much more onerous than in ‘normal’ projects.

#### *Other fire suppression systems*

Recent developments in fire suppression systems include the use of water mist and gas suppression systems; the latter, while generally regarded as safer for fabrics found in some historic buildings, do reduce the oxygen content of the air and are therefore a risk to occupants. Proprietary inert gas systems are now available that allow humans to continue to breathe where the mixture has been discharged. However, for large areas they are unsuitable due to the quantity of gas required and the difficulty of maintaining the appropriate concentrations of gas for the duration of the fire’s life. They can be ideal, though, for smaller spaces, such as archive storage rooms or high risk areas such as transformer chambers and switchrooms.

Other than marine or industrial situations, water mist and fog type fire suppression systems are increasingly being used in risk situations and have proved beneficial in safeguarding specific hazards. Unfortunately there are no British or European standards covering their use and, while work is ongoing to produce a suitable standard for the application of water-mist fire suppression systems, there is little authoritative documentation and guidance currently available to the designer and building professional.

#### **2.15.5 Related standards**

Standards related to this standard are:

- Standard 1.1 Structure
- Standard 2.1 Compartmentation
- Standard 2.2 Separation
- Standard 2.3 Structural protection
- Standard 2.4 Cavities
- Standard 2.5 Internal linings
- Standard 2.9 Escape
- Standard 2.12 Access for fire appliances
- Standard 2.13 Water supplies for fire-fighting
- Standard 2.14 Facilities for fire-fighting

## 3. ENVIRONMENT

### 3.1 Site preparation: Harmful and dangerous substances

#### Standard 3.1

Every *building* must be designed and *constructed* in such a way that there will not be a danger to the *building* nor a threat to the health of people in and around the *building* due to the presence of harmful or dangerous substances.

#### Limitation

This standard does not apply to the removal of unsuitable material, including turf, vegetable matter, wood, roots and topsoil on the *site* of a *building* (other than a *dwelling*) intended to have a life not exceeding the period specified in regulation 6.

#### 3.1.1 Type of Standard

##### **Reasonably practicable standard**

Every *conversion*, to which these regulations apply, must be improved to as close to the requirement of the standard as is *reasonably practicable*, and in no case be worse than before the *conversion*.

#### 3.1.2 Commentary

There may be a view that this standard has little relevance to the conversion of a historic building and that it is designed to deal with new developments on previously contaminated land. There are, however, a number of situations where the presence of harmful and dangerous substances can impact upon a historic building and its occupants. Examples of historic building conversions where contaminants may be present are:

- a) Where the previous use of the building allowed the possibility of spillage or release of contaminants such as chemicals, toxic metals, oils, asbestos and other hazardous fibres and particulates etc.
- b) Where the building was previously used to house animals eg cattle byres.
- c) When the fabric of the building contains harmful and dangerous materials such as asbestos, lead water pipes, historic lead-based paint etc.
- d) Where there is contaminated land immediately adjacent to the building, which may be disturbed during the conversion, for example when installing surface water drainage to control moisture levels in the underbuildings.
- e) Where a pathway exists by which a contaminant can reach the building, for example, contaminated ground water from a pollutant source being directed to the building.

In addition, this standard also covers the treatment of the solum of buildings to prevent vegetable growth and evaporation of moisture from the ground. There is also a requirement for any part of the underbuilding that is in contact with the ground, such as sloping ground, to be tanked. Further information is contained in Part II, Section 3.4, *Moisture from the ground*, when dealing with this issue.

As far as the conversion of a historic building is concerned, this standard is a '*reasonably practicable*' standard, which gives some flexibility as to how far it is implemented provided that the situation is no worse than before the

conversion. This means it is possible that, for example, additional treatment of the solum may not be required. However, where there is an established risk to the building or to the health of people in and around the building, remedial action will normally be required.

A site-specific risk assessment should be carried out where the past history of the site indicates the possibility of contaminants being present.

### 3.1.3 Issues to be considered

Issue	Risks to historic/traditional buildings
1. Harmful or dangerous substances	<ul style="list-style-type: none"> <li>• Where historic lead-based paint finishes are present there will be pressure to remove such finishes and replace with modern, non-toxic paints – this may lead to a loss of an important historic decorative scheme.</li> <li>• Many historic buildings have had systems installed that incorporate asbestos insulation. However, this is unlikely to be original to the building and its removal will not present a risk to the building if carried out in a properly controlled way. Note: if the asbestos containing material is in sound condition, the advice from the Health and Safety Executive is to leave it in place (refer to Part I, Section 2.5.5 for further information).</li> <li>• Former farm steadings, stables and the like, where animals have been housed, will be contaminated with faecal matter. The greatest risk is to hidden archaeology below the floor and in the ground surrounding the building when contaminated material is removed.</li> <li>• Treatment or removal of building fabric that has been impregnated with contaminants, especially porous materials.</li> <li>• Existing walls may be undermined and services disrupted by removal of contaminants up to 1m deep.</li> </ul>
2. Solum treatment	<ul style="list-style-type: none"> <li>• Treating the solum of a historic building to raise its level to that of the adjoining ground can be disruptive to historic floors.</li> </ul>

### 3.1.4 Recommendations to meet the standard

Each site must be subject to site-specific risk assessment, which must take into account the sensitivity of the intended use of the site. It is necessary to recognise the specific source(s), pathway(s) and receptor(s), and the extent of remedial treatment required to ensure that human health, the building and the environment are no longer at risk. In the case of housing, the risk assessment, and the nature of pollutant linkages, will depend on the following factors and their relationship to the contaminant:

- the design and layout of the conversion;
- whether the site includes gardens and, if so, where they are situated;
- any harmful or dangerous materials which are peculiar to the conversion and the precautions that will be used in construction.

Points that should be considered to reduce risk to people and buildings prior to work commencing are:

- local knowledge should be actively sought on the past history of the site and surrounding area;
- the history of the site can provide clues to whether the site is contaminated and reference to current and historical OS maps and site plans can provide evidence of contaminants;
- a walk over the site can provide other valuable clues, including the type of vegetation (or lack of it), any unusual smells or suspicious containers;
- a soil and site investigation may be considered if the desktop study and walk-through show possible contaminators (such as middens etc.);
- this standard requires a hazard identification and assessment to be carried out, for which a risk assessment specific to the site is required;
- the site should be considered as a pathway or receptor of contamination, and advice from the appropriate environment section of the local authority should be sought on these risks in order to reduce risk when developing the site;

- a restoration plan (also known as a remediation or risk management plan) should be prepared for the contaminated site – refer to planning advice note PAN 33, 2000, for further information.

Points that should be considered to reduce the risk to the occupants and the building during the conversion of a historic building are:

- the type of contaminant defines the approach to its removal and/or treatment, and in all cases it assumes the contaminated area within and around the building will have 100mm of concrete capping;
- expert advice for remediation should be sought in cases where contamination has been found and specialists employed for the removal of the contaminants;
- if contamination is found during construction the Verifier should be informed immediately;
- contaminants in most cases should be removed by experts, and advice sought from the Verifier in this regard;
- licenses may have to be sought for removal of some contaminants;
- the potential impact of any removal or treatment of contaminants on the fabric or character of the building must be included within the conservation plan for the building.

Treating the solum of historic buildings to meet the recommendations of the standard may be destructive to historic floors should they require to be lifted to raise the solum level and to treat the surface. However, unless there is evidence that the existing solum is a source of unacceptable dampness that is causing damage to the building, is a risk to the health of occupants, or is supporting vegetable growth (including fungal growth), the least damaging approach may be to leave the existing solum as it is. Where there is evidence of high moisture levels then the recommendations contained in Section 3.4, *Moisture from the ground*, should be followed.

Further guidance and sources of information may be obtained from:

Planning Advice Note (PAN) 33

Code of Practice BS 10175: 2001, *Investigation of potentially contaminated sites*. (supersedes DD 175: 1988)

Code of Practice BS5390: 1999, *Site Investigations*

CIRIA, Special Publications 101–112 (1995–97), *Remedial treatment of contaminated land*, Vols I–XII.

### 3.1.5 Related standards

Other related standards are:

- Standard 3.2 Site preparation: protection from radon gas
- Standard 3.4 Moisture from the ground

## 3.2 Site preparation – protection from radon gas

### Standard 3.2

Every *building* must be designed and *constructed* in such a way that there will not be a threat to the health of people in or around the *building* due to the emission and containment of radon gas.

#### 3.2.1 Type of standard

##### *Reasonably practicable standard*

Every *conversion*, to which these regulations apply, must be improved to as close to the requirement of the standard as is *reasonably practicable*, and in no case be worse than before the *conversion*.

### 3.2.2 Commentary

Radon is a natural radioactive gas that decays into other radioactive species, all of which cause human exposure to radiation and have, with prolonged exposure, been linked to lung cancer. Radon is naturally occurring, being present in rocks and soils and also in products produced from them (eg stone, concrete and bricks). The standard identifies certain areas of Scotland where radon is deemed to be present in sufficiently high concentrations to constitute a health risk to occupants of buildings. These areas are concentrated in two main locations, where steps to reduce radon levels are recommended. These areas are defined in the maps in the Standard and are confined to eastern Sutherland/Caithness and in Deeside and Kincardine in Aberdeenshire.

When dealing with the conversion of historic buildings, only reasonably practicable action needs to be taken to ensure that exposure to radon is no worse than before the conversion. However, to safeguard the health of occupants, it is desirable to implement measures to reduce radon levels that are compatible with the conservation of the building. Tests conducted in the building will confirm the level of risk and whether radon reduction measures are necessary. Radon reduction, sometimes called radon mitigation, should be implemented when levels exceed the action level of 200 Bq/m<sup>3</sup> (becquerels per cubic metre).

Buildings that have been effectively draught-proofed as an energy conservation measure will have reduced levels of ventilation, and therefore may have higher radon concentrations.

### 3.2.3 Issues to be considered

Issue	Risks to historic/traditional buildings
Radon protection measures	<ul style="list-style-type: none"> <li>• Installations can be visually intrusive, for example, external fans and vent pipework.</li> <li>• Radon sumps within buildings may disrupt historic solid floors.</li> <li>• Sealing up fireplaces and cracks to reduce radon levels can increase fabric moisture levels.</li> </ul>

### 3.2.4 Recommendations to meet the standard

Where radon levels exceed the action level, it will normally be possible to implement at least some radon reduction measures without adversely affecting the historic character of the building being converted. There are three main methods of radon reduction for existing buildings when levels exceed 200 Bq/m<sup>3</sup>. For further information refer to DEFRA (2003), *Reducing radon levels in the home* and to the BRE publication, BRE 376 *Radon guidance on protective measures for new dwellings in Scotland*.

#### a) Radon sump method

This method is for use with solid concrete (or similar) ground floors. A sump, which is a bucket-sized void, is excavated just inside an external wall and a 110mm diameter pipe leading from the sump is passed through the wall. A fan, connected to the pipe, draws air from the soil beneath the floor and vents it harmlessly to the air above eaves level. A prefabricated sump may be used as an alternative. This method is, however, visually intrusive but it is possible to share a sump system between buildings, which may reduce the visual impact and floor disruption.

A less visually intrusive version of the method is to use a *passive sump system* when it may be not necessary to install a fan. In this case the pipe from the sump is routed up through the building to vent at the highest point by passive stack ventilation (refer to Part II, Section 3.14 for further information on passive stack ventilation).

#### b) Improved ventilation under suspended floors

This is likely to be the most commonly employed method in a historic building with a suspended ground floor. Not only does this method reduce radon but it is also good for the building. It works by ensuring that sufficient ventilation is provided below the floor. Installing additional sub-floor vents may be sufficient where radon levels are relatively low. For higher radon levels, a fan installed at one side of the property can be used to increase air flow rates and remove radon laden air.

Historic buildings typically have open fireplaces and chimneys, which keep the property well ventilated. However, chimneys tend to draw air into a room from other areas, for example from below a suspended timber floor, which may increase radon levels in the room. In this case, one option is to block the chimney, cap it with a chimney-pot hood and install a small vent in the blocked fireplace. Such an approach may not be acceptable where the character of the room is adversely affected by sealing the fireplace opening.

Sealing up large holes and cracks in a suspended timber floor is recommended as this will reduce radon penetration into room spaces, but will reduce the ventilation within the room, which should be compensated for by other means. Covering the entire floor with an impervious membrane to act as a seal against radon is not recommended, as this will increase the risk of timber decay. Sealing cracks reduces the flow of radon into rooms and is often used with other methods. However, sealing cracks alone has been shown not to lower radon levels significantly or consistently.

Increasing ventilation inside the building can effect a small reduction in radon levels by dilution but should only be used in conjunction with other measures. Buildings that make use of open fires and solid-fuel-effect open fires will draw radon-laden air into rooms, as will the continuous use of extractor fans in kitchens and bathrooms.

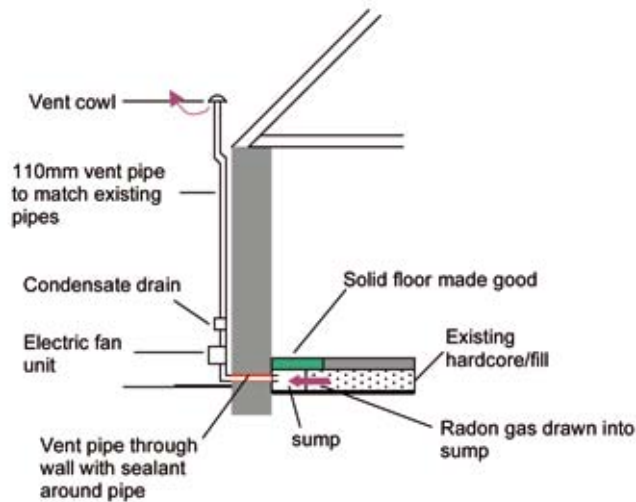

Illus 3.2.1 Radon sump system installed in an existing solid floor.

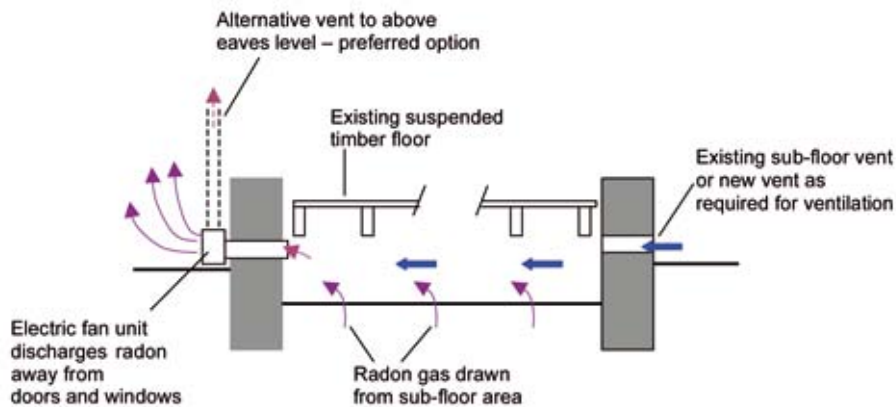

Illus 3.2.2 Improved radon ventilation under a suspended floor.

c) Positive pressurisation

This method works by diluting the radon entering the building. A specially installed fan blows air from the roof space – or fresh air from outside – into the building thus maintaining a positive air pressure inside. However, the efficiency of this system for a historic building is likely to be poor as the system works best with well-sealed buildings.



### 3.2.5 Related standards

Other related standards are:

- Standard 3.4 Moisture from the ground
- Standard 3.14 Ventilation
- Standard 3.15 Condensation
- Standard 6.6 Mechanical ventilation and air conditioning

## 3.4 Moisture from the ground

### Standard 3.4

Every *building* must be designed and *constructed* in such a way that there will not be a threat to the *building* or the health of the occupants as a result of moisture penetration from the ground.

#### 3.4.1 Type of standard

##### *Reasonably practicable standard*

Every *conversion*, to which these regulations apply, must be improved to as close to the requirement of the standard as is *reasonably practicable*, and in no case be worse than before the *conversion*.

#### 3.4.2 Commentary

The requirement of this standard is that a floor, wall or other building element adjacent to the ground should prevent moisture from the ground from reaching the inner surface of any part of a building where it may constitute a health risk to occupants. The standard also identifies the need to recognise the impact that climate change could have on the fabric of buildings through increased rainfall and temperatures.

This standard is designed for new-build construction and, if implemented fully for the conversion of a building of traditional construction, is likely to be detrimental to the fabric of the building. It is designed to prevent the penetration of moisture from the ground by the introduction of damp proof courses in walls and damp proof membranes below ground floors.

In the conversion of a historic building the usual types of construction encountered in Scotland do not normally permit the introduction of a DPC within the wall and often, where such elements are introduced, the results have not been successful. The most common cause of dampness at the base of walls of traditional buildings is often found to be due to defective ground drainage. The factors shown below are the most usual causes of dampness from the ground:

- blocked (or non-existent) ground drainage,
- raised adjoining ground levels over the years,
- the application of hard cement base-course renders at ground level and
- the use of impervious finishes around buildings that direct water back towards the walls.

It follows, therefore, that correction of these defects should be the first course of action. In addition, it is possible that condensation on surfaces at the base of the wall may be a contributory factor to the 'rising damp' problem. Refer to Section 4.3.1 in Part 1 of this book for further information.

An additional factor that affects the moisture condition of walls and suspended floors is the need for ventilation to assist in the removal of moisture from walls and sub-floor spaces. Maintaining an adequate flow of air at these points is an essential feature of moisture control.



*Illus 3.4.1 Dampness in a lime mortar rendered wall (Category B listed, mid-C19) (Photo: D Urquhart).*

*Note: The volume of moisture from the ground, from the chimney area and the pre-existing dampness in the wall has overcome the potential for the render to transpire the moisture. Applying render to a saturated wall is not good practice. In this case all sources of moisture should have been addressed before render was applied. In the case of moisture from the ground, lowering the ground level and installing a French drain would be a means of reducing moisture rise in the wall. A new concrete floor may have been laid on a DPM, which has exacerbated the problem of moisture from the ground.*



*Illus 3.4.2 Damproofing inserted into a historic wall, circa mid-C19 (listed Category C(S)) (Photo: D Urquhart).*

*Note: In this example it is likely that the dampness problem has been exacerbated by the application of hard cement render and the installation of a new concrete ground floor on a DPM. The rear wall of the building is unrendered rubble, which has not had a DPC installed.*

Basements are a potential source of dampness. However, it has to be recognised that in most historic buildings basements were generally not intended to be permanently occupied. They were used as storage spaces, cellars or work places such as kitchens and laundries. As such they were generally finished to a lower standard than other parts of the building and, as a purely working area, these below ground rooms were adequate for purpose, and dampness would not be a major concern. Also, some basements were meant to be damp to keep food cool. However, dampness is the most common defect encountered in a basement and, where a basement has to be converted into a habitable space, the causes of dampness must be removed.

Before progressing with a basement conversion, even if the standard and quality of the existing finishes may be lower than in the rest of the property, it is still important to identify all elements of cultural significance that may be present and to conserve these elements as far as is possible. In many cases, basements will have been poorly treated over the life of a building and there may be little of significance remaining, apart from historic forms such as vaulted roofs and the like, which should be conserved. Vaulted and arched basement roof structures are difficult to waterproof effectively because of their construction. They are also prone to future structural movement due to imposed loads from adjacent roads, car parks and paths, which may disrupt the waterproofing.

Where other walls – such as earth retaining walls, garden walls and arches – abut basement and sub-basement walls they can encourage moisture transfer from the ground into the building. The effect can be that moisture is directed into the wall, often under a pressure sufficient to produce running water at the inside face.

The conversion of a basement into habitable accommodation will mean that it is of vital importance to ensure that effective damp proofing of the basement is carried out and that the treatment method selected has a life at least equal to the life of the conversion. It is important to ensure also that any treatment method does not have the effect of driving moisture higher up the wall. Traditional tanking of the inside face of a porous basement retaining wall would have this effect.

Other problems associated with basements may be a low ceiling height (which could mean reducing the level of the floor with its associated problems), absence of natural light and ventilation.

### 3.4.3 Issues to be considered

Issue	Risks to historic/traditional buildings
1. Rising damp	Refer to Part 1, Section 4.3.1, <i>Moisture from the ground</i> . Key points are: <ul style="list-style-type: none"> <li>• Insertion of damp-proof courses in masonry and earth walls may contribute to raised moisture levels, both below and above the DPC – moisture becomes ‘locked in’;</li> <li>• A damp-proof membrane below a new concrete ground floor reduces moisture evaporation and can encourage a greater flow of moisture towards floor perimeters and into porous walls;</li> <li>• Cutting a thick masonry wall to insert a physical DPC can be destructive to the wall and chemical damp-proofing methods can be unreliable in rubble-cored walls, leaving untreated gaps within the wall;</li> <li>• Reducing ventilation at floor/wall junctions can raise the moisture content of adjacent plaster and timber.</li> </ul>
2. Basements	<ul style="list-style-type: none"> <li>• Damp-proofing an existing basement requires very careful consideration of the wall construction, internal conditions and external ground hydrostatic pressures;</li> <li>• Applying impervious render or other waterproofing material to the inside face will trap moisture behind the surface and drive it further up the wall to emerge at a higher level.</li> </ul>

### 3.4.4 Recommendations to meet the standard

#### a) Ground floors and wall-floor junctions

In the control of rising damp in a historic building it must be remembered that this is only one of a number of mechanisms that can result in high moisture levels in the base of walls of traditional construction. The most effective means of managing dampness, without adversely affecting historic construction, is to ensure that the source of dampness has been properly identified. The most appropriate and cost-effective methods of controlling the moisture can then be implemented.

The installation of damp proof courses in traditional masonry walls is fraught with difficulties, and is generally recommended only as a last resort when rising damp has been properly identified as the cause of dampness and other methods have been ineffective. The first step in any wall treatment is to reduce the volume of moisture moving from the ground into the wall. The normal method is to adopt passive measures to ensure that surface water is drained clear of the foundations. Installing a 'French' drain is the traditional solution. However, the design and construction of these drains is often unsatisfactory and may collect water rather than effect its removal. Reasons for unsatisfactory performance can be:

- poor design,
- lack of falls,
- drain becoming clogged up with soil and debris,
- clay soils acting as a 'sump' for ground water,
- poor selection of granular fill or backfilling with soil.

In addition, the provision of paving drained away from the wall, where this is possible, is a valuable additional measure to reduce ground water levels.

The trend towards replacing suspended timber floors with concrete ground floor slabs may not be the most appropriate solution to the rising damp problem. The generally preferred option is to retain or reinstate the timber ground floor and ensure adequate through ventilation is provided. Many historic buildings have inadequate ventilation; either because of insufficient ventilation area or because of ventilation being restricted by later additions to the building.

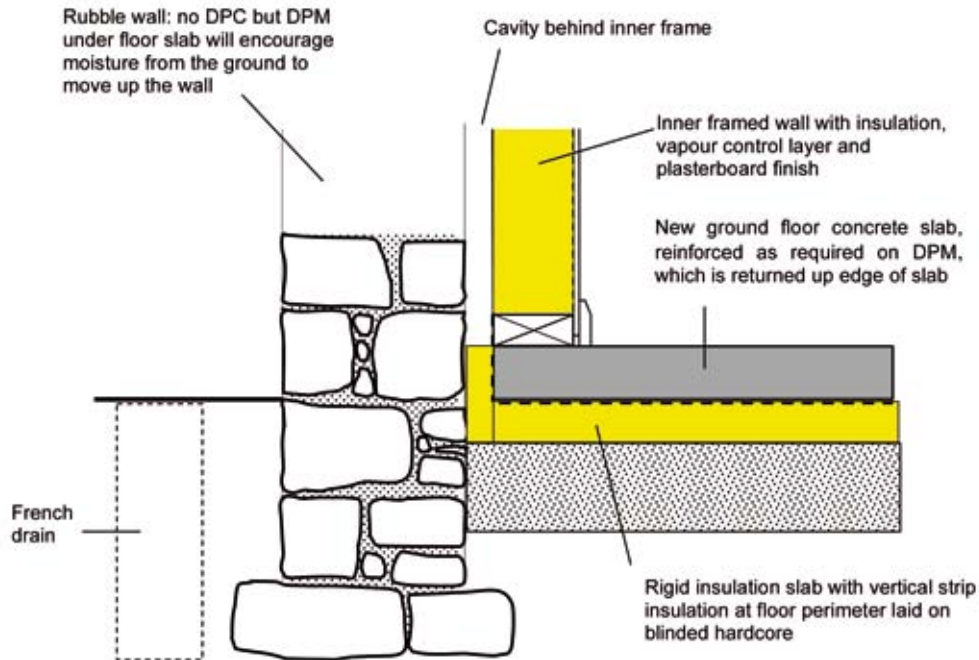

*Illus 3.4.3 Junction of new concrete floor slab with existing wall.*

*Note: new concrete slab and DPM, and internal wall insulation with plasterboard finish used only when there are no existing historic floors and wall finishes.*

Illustration 3.4.4 typically represents moisture transpiration into the sub-floor space of a suspended timber floor and the control of the moisture by adequate ventilation. In this case the insulation of the floor has been improved by the installation of rigid thermal insulation, kept clear of adjoining masonry to allow free movement of air.

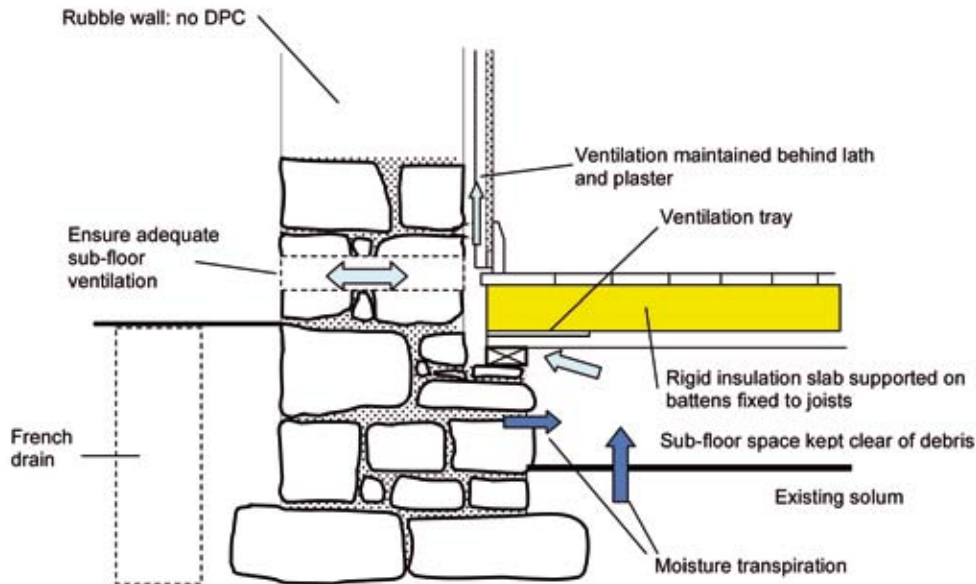

*Illus 3.4.4 Ventilation of a suspended timber ground floor.*

Occasionally, a historic stone flag floor has to be retained. In this case the temptation to lift the floor and insert a fully insulated concrete slab below the re-laid (or replaced) flagstone should be resisted. Apart from their historic significance, these floors, when laid in the traditional manner on a lime mortar base, usually perform well in terms of damp resistance. They will keep water pressures below the floor under control by transpiration of moisture into the ventilated room above, thus preventing additional ground water being directed into adjoining walls. Where possible the original flags should be retained and excessively worn flags can be turned over and re-laid (Illus 3.4.6).

The temptation to apply a modern impervious floor covering on top of the flagstones should be resisted as this will trap moisture below the covering and prevent evaporation through the flagstone floor. It may also increase dampness elsewhere. The application of sealers to the surface of the flagstones will create a similar effect.

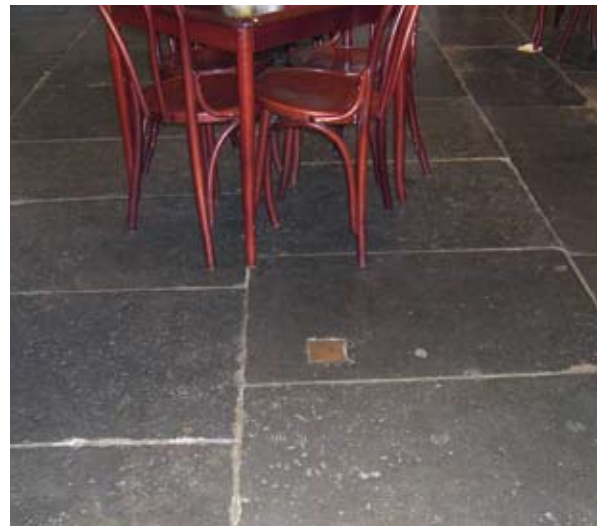

*Illus 3.4.5 Traditional flagstone floor re-laid in converted Category A listed building (Photo: D Urquhart).*

Where there is evidence of dampness (rising damp) on the flagstone floor and/or adjacent walls, the source or sources of the moisture should be investigated and eliminated. Often lowering the external ground level and the installation of French drains will be sufficient to control the dampness. However, in some cases where ground water control has not proved to be effective, the insertion of a damp proof membrane may be required below the floor. Care should be taken in the investigation to ensure that the dampness has been properly identified and is not due to condensation.

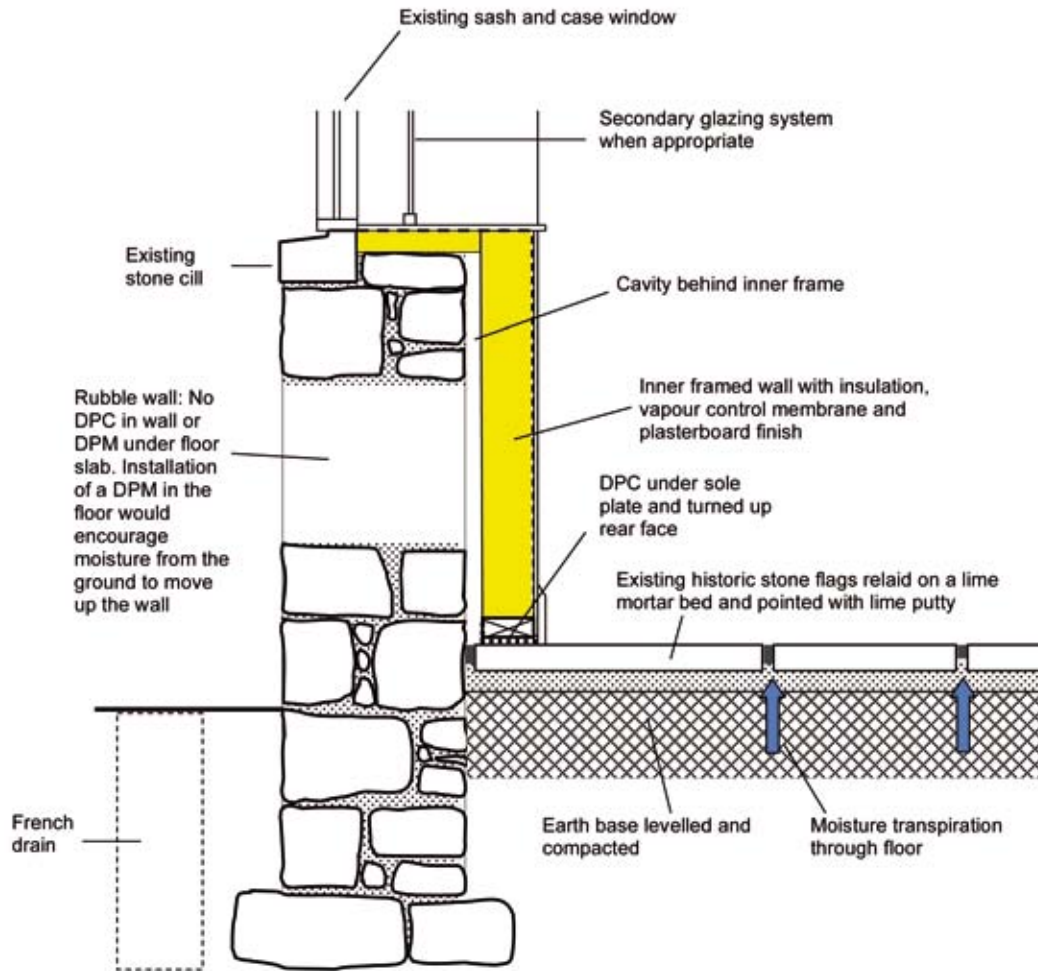

Illus 3.4.6 Detail of a traditional stone flag floor that has been lifted and re-laid.

*b) Basements*

Waterproofing of a historic basement to permit the formation of habitable accommodation can be a challenging exercise. The rules that apply to ground floors apply also to basements, where inappropriate treatment can encourage moisture to rise higher up the wall than would otherwise be the case. Relief of hydrostatic pressure within the construction must be part of the overall design.

The traditional approach to providing a habitable basement space is to adopt the drained cavity method, in which a dry envelope is constructed inside the existing structure. In all cases the cavity behind the dry envelope should be ventilated to dissipate moisture. Inevitably such a system will encroach into the usable space. There are available, however, proprietary systems using modern materials and techniques that may be used to achieve the same outcome, but which do not make the same demands on space. These include specialist plastic membranes applied to the inside face of the existing wall, which allow moisture from the wall to drain down into a special drainage system at the wall/floor junction. In this way hydrostatic pressure is relieved without the need for a large gap between the existing wall and the new internal linings. Illus 3.4.7 is a representation of such a system.

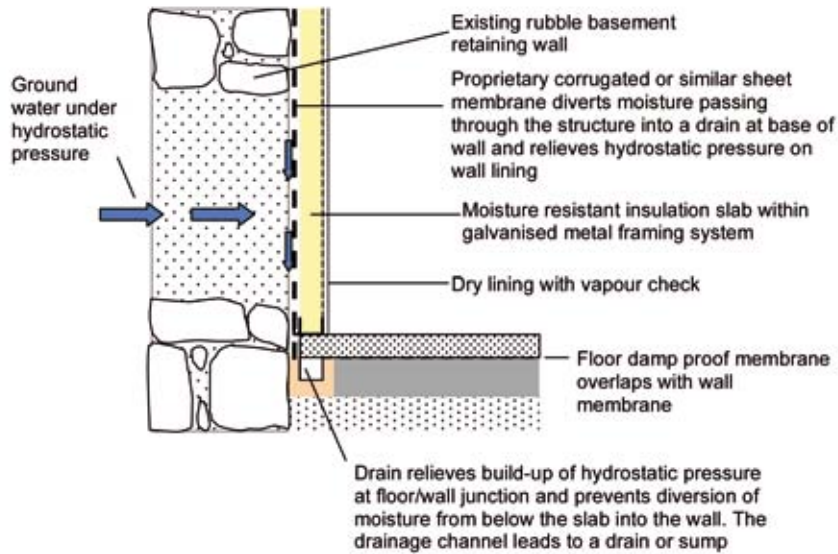

Illus 3.4.7 Diagrammatic representation of a proprietary basement wall treatment system.

### 3.4.5 Related standards

Other related standards are:

- Standard 3.6 Surface water drainage
- Standard 3.14 Ventilation
- Standard 3.15 Condensation
- Standard 6.2 Building envelope insulation

## 3.6 Surface water drainage

### Standard 3.6

Every *building*, and hard surface within the *curtilage of a building*, must be designed and *constructed* with a surface water drainage system that will:

- (a) ensure the disposal of *surface water* without threatening the *building* and the health and safety of the people in and around the *building*; and
- (b) have facilities for the separation and removal of silt, grit and pollutants.

### 3.6.1 Type of standard

#### Mandatory standard

In the case of *conversions*, the *building as converted* must meet the requirement of this standard.

### 3.6.2 Commentary

This standard has significant implications for the conversion of historic buildings. To simply accept the current system, or adopt a conventional piped surface water system, may not be acceptable in all circumstances. For buildings, the existing rainwater disposal system may be entirely appropriate where the gutters and downpipes are constructed and installed in a way that allows surface water to be removed quickly and safely. However, the system will have to be improved to the required standard where the assessment of the building prior to its conversion shows that the existing surface water drainage system may result in damage to the building, pose a danger to people around the building (particularly to disabled people) or create a risk to the environment by flooding or pollution.

Water is the ‘engine’ of decay in historic buildings. Frequently, the decay and deterioration of historic fabric can be directly attributed to inadequate design and/or lack of maintenance of roof drainage elements. The resulting saturation of masonry is a primary cause of dry rot (*S. lacrymans*), stone decay and dampness in internal spaces. Drainage of surface water is thus a vital element in the conservation of historic buildings, and existing historic drainage features which are promoting decay of the building may have to be replaced with a system that does not pose a risk to the building.

In meeting this standard it should be possible, in the majority of situations, both to comply with its requirements and maintain the historic character of the building. For example, many historic buildings do not have a system of eaves gutters and downpipes, but rely on overhanging eaves to shed water clear of the building. In the past, this has created problems for the character of the building when local authorities have insisted upon the installation of roof drainage in a conversion. However, this standard allows for an *eaves drop system* to be used (ie roof drainage without gutters and downpipes); providing the design takes into account the need to protect fabric, elements, foundations and persons. Where the roof has an area of not more than 8m<sup>2</sup> no restrictions apply.

It is in the surface water drainage of paved surfaces that the application of the standard may have a detrimental impact on the character of the building, including its curtilage. Historic paved surfaces might not be able to remove surface water efficiently, or their drainage discharge might endanger the environment. In upgrading the surface water drainage system there is a danger that hidden archaeology could be disturbed by excavation work.

The requirements of this standard, which is an essential standard for conversions, means that each surface within the curtilage of the building must be assessed against the criteria set out in the standard. A small paved surface of less than 200m<sup>2</sup> is unlikely to present a problem. However, larger areas may need to be resurfaced and drainage installed that incorporates a Sustainable Drainage System (SUDS) or uses a traditional piped system that does not endanger the environment. Fortunately, there are many surfacing systems available that meet both the requirements of the standard and are sympathetic to the historic environment.

### 3.6.3 Issues to be considered

Issue	Risks to historic/traditional buildings
1. Surface water drainage from buildings	<ul style="list-style-type: none"> <li>• Risks to historic buildings are unlikely to be increased by the application of this standard unless existing roof drainage elements are replaced with alternatives that are unsympathetic to the historic character.</li> </ul>
2. Surface water drainage of paved surfaces	<ul style="list-style-type: none"> <li>• Historic paved surfaces may have to be replaced with a surface that is designed to prevent ponding of water, especially on access routes suitable for disabled people: historic character can be adversely affected by unsympathetic alternative surfaces.</li> <li>• Installation of new drainage may disturb hidden archaeology.</li> </ul>
3. Surface water discharge, soakaways and SUDS	<ul style="list-style-type: none"> <li>• The SUDS system advocates managing the site so that the quantity of runoff is reduced through minimising paved areas and directly connected areas. This means that, without careful design of surface runoff adjacent to buildings, dampness in walls at ground level may be increased.</li> <li>• Installation of new drainage and infiltration devices (soakaways etc.) may disturb hidden archaeology.</li> </ul>



### 3.6.4 Recommendations to meet the standard

#### a) Surface water drainage from buildings

Unless the design of the existing roof drainage system is defective and causing damage to historic fabric or the condition of the system is such that replacement is necessary, there is unlikely to be a need to take direct action to meet the standard. However, should a new design or a replacement system become necessary the requirements of the standard will apply.

Where possible, gutters and downpipes should be constructed and installed in accordance with BS EN 12056-3: 2000. In many cases there will be a need to use replacement gutters and downpipes that replicate the original, both in design and materials. But, as the BS is not specifically designed to accommodate historic buildings, it may be that traditional replacement components do not fully accord with the British Standard. In such cases, to avoid the use of unsympathetic modern components, it is recommended that the past performance of these components and materials be accepted as a suitable means of meeting the standard where the roof area or form has not been altered.

An existing building without eaves gutters and downpipes (*an eaves drop system*) is an acceptable method of roof drainage. Where this arrangement of rain water runoff from a historic building has not had an adverse effect on the building, on the health and safety of people in and around the building or on the environment, no changes to the system need be made. However, where a risk assessment of the free fall of water from roofs indicates the following risks, remedial action will be required.

Risk	Remedial action
1. Concentration of water runoff onto walls causing decay	<ul style="list-style-type: none"> <li>Eaves catchment and rain water disposal required, possibly using eaves gutters or eaves hoppers as appropriate.</li> </ul>
2. Ponding or constant wetting of access routes (potential for slipping due to ice or algal films)	<ul style="list-style-type: none"> <li>Replace with a permeable surface (although must be suitable for disabled access). Note: a permeable surface may not be sufficient to clear an access route of standing water quickly enough and additional measures will be required.</li> <li>Relay the surface to provide water runoff.</li> </ul>
3. Splash back from the ground onto walls	<ul style="list-style-type: none"> <li>Use a gravel layer around the base of the wall.</li> </ul>
4. Discharge from the roof concentrated onto a small area with a risk to shallow foundations.	<ul style="list-style-type: none"> <li>Install a hopper at roof level with a downpipe discharging clear of the foundation.</li> </ul>
5. Impervious soils	<ul style="list-style-type: none"> <li>The formation of permeable surfaces and sub-base in impervious soils such as clays may act as a 'sump' for water and encourage the movement of moisture into the building.</li> </ul>

Illus 3.6.2 is appropriate for permeable soil conditions. Where the building has an eaves drop system and the soil is impermeable then additional drainage will be required to prevent ponding. This drainage, for example, may consist of a perforated drain, with rodding eyes, connected to a soakaway sized to deal with the design flow load and located well clear of the building.

#### b) Surface water drainage from paved areas

To prevent physical damage to historic buildings and for the safety of people it is essential to remove surface water quickly and efficiently from paved areas. This may be achieved using either a SUDS system or a traditional piped drainage system. Permeable surfaces and filter drains are a preferred option. CIRIA (2001) provides further guidance, which can be obtained from their web site <http://www.ciria.org.uk>. These surfaces have a permeable pavement and sub-base (Illus 3.6.2) to store and dissipate surface water. Various surfaces can be used that are compatible with the character of historic buildings. Surfaces can include the following (not all are suitable for access to buildings):

- grass (if not trafficked),
- reinforced grass,

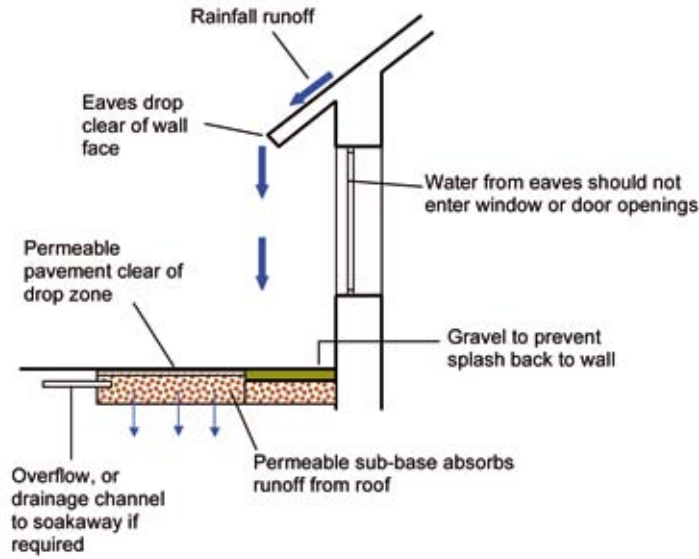

*Illus 3.6.2 Eaves drop roof drainage system to prevent splashing of water on the wall (to comply with BRE Digest 365).*

- gravelled areas,
- solid paving blocks with large vertical holes filled with soil or gravel,
- solid paving blocks with gaps between individual units,
- porous paving blocks with a system of voids within the unit,
- continuous surfaces with an inherent system of voids.

*c) Surface water discharge*

The traditional methods of surface water discharge to a soakaway, a public sewer, an outfall to a watercourse or, if the surface water is from a dwelling, to a storage container are still suitable methods. Therefore, for most historic buildings it is likely that the existing system, provided it complies with the requirements of the standard, will be acceptable. However, the sustainable management of surface water drainage (SUDS) is now the preferred option when a new system is required. SUDS can be designed to suit most urban and rural environments.

**3.6.5 Related standards**

Other related standards are:

- Standard 3.4 Moisture from the ground
- Standard 4.1 Access to buildings

### 3.11 Facilities in a dwelling

#### Standard 3.11

Every *dwelling* must be designed and *constructed* in such a way that the size of any *apartments* or *kitchens* and the access to other *rooms* does not threaten the health of the occupants.

Limitation

This standard applies only to a dwelling.

#### 3.11.1 Type of standard

##### **Mandatory standard**

In the case of *conversions*, the *building as converted* must meet the requirement of this standard.

#### 3.11.2 Commentary

There should seldom be occasions where the historic fabric of a building inhibits compliance with this standard. Similarly, it is unlikely that the character of a historic property will be adversely affected in accommodating its essentially undemanding space requirements. Where there are restricted pre-existing room sizes, it may be necessary to locate storage for kitchens and bedrooms in locations more remote from the rooms than would be normally accepted.

From May 2007, draft amended standard 3.11 is:

*Every building must be designed and constructed in such a way that*

- a) The size of any apartment or kitchen will provide a level of amenity that ensures the welfare and convenience of all occupants and visitors; and*
- b) an accessible space is provided to allow for the safe, convenient and sustainable drying of washing.*

*Limitation*

*This standard applies only to a dwelling*

This amendment will introduce requirements for drying facilities. These requirements will apply to conversions, but can be fulfilled in a variety of ways so should not create specific problems for older buildings.

#### 3.11.3 Issues to be considered

Issue	Risks to historic/traditional buildings
1. Provision of activity spaces	<ul style="list-style-type: none"> <li>• Well-planned room spaces should not present a risk to historic buildings, unless room proportions are altered to the detriment of historic character.</li> </ul>
2. Floor to ceiling height	<ul style="list-style-type: none"> <li>• Inappropriate roof projections (dormer windows etc.) to increase designated room areas.</li> </ul>

#### 3.11.4 Recommendations to meet the standard

The minimum floor to ceiling height of any part of the designated area of a room is 1.5m and, for an activity space designated for use by disabled people, the height across the full area of the activity space should be not less than 1.8m. Achieving these headroom requirements for activity spaces could be a problem in some rooms with coomed ceilings. However, with good space planning it should be possible to achieve the requirements of this standard without loss of historic character.

In situations where alterations to the roofline are thought to be necessary to increase the floor areas to achieve the

space standard, every effort must be made to find alternative solutions that avoid such alterations. Adding dormer windows and projections to historic roofs may have a serious impact on both historic character and fabric. If, however, such alterations are the only possible solution, the design, construction and materials must respect the historic form and character of the building.

In addition to the above requirements, for houses designated as Houses in Multiple Occupation (HMOs) there are Benchmark Standards setting out the minimum space requirements for bedrooms and communal living rooms. These space standards for HMOs may be more demanding than those of this standard (refer to Part I, section 7.4 for further advice on HMOs).

### 3.11.5 Related standards

Other related standards are:

- Standard 3.12 Sanitary facilities
- Standard 3.16 Natural lighting

## 3.12 Sanitary facilities

### Standard 3.12

Every *building* must be designed and *constructed* in such a way that *sanitary facilities* are provided for all occupants of, and visitors to, the *building* and that there is no threat to the health and safety of occupants or visitors.

#### 3.12.1 Type of standard

##### *Mandatory standard*

In the case of *conversions*, the *building* as converted must meet the requirement of this standard.

#### 3.12.2 Commentary

The Technical Handbooks to building standards specify the number of water closets (or waterless closets), washbasins, baths or showers and sinks required in domestic and non-domestic buildings. Many pre-1920 domestic properties were designed without separate toilets or bathrooms. If these properties have remained in domestic use most will have already been upgraded to include a bathroom with water closet or a bathroom and separate toilet. However, the requirement to provide an accessible toilet from public areas is likely to be the issue that will create the most difficulty in a historic building conversion. The space for such an installation may not be available within existing accommodation without disrupting the character of the space.

In addition to the provision of new sanitary facilities, the design, routing and installation of water supply, soil and waste drainage and ventilation to serve the facilities need to be planned very carefully if unacceptable disruption to historic fabric and spaces is to be avoided. Accommodation of soil and waste drainage, for example, can be difficult to achieve within the thickness of an existing floor, and ‘boxing-in’ of pipework below a floor is unlikely to be an acceptable solution. Similarly, the creation of vertical ducts within historic spaces will be disruptive to the character of the space. Wherever possible the installation of services to sanitary accommodation should be routed within existing voids and ducts.

From May 2007, draft amended standard 3.12 is;

*Every building must be designed and constructed in such a way that sanitary facilities are provided for all occupants of, and visitors to, the building in a form that allows convenience of use and offers no threat to the health and safety of occupants or visitors.*

This amendment introduces guidance on more accessible sanitary facilities. The guidance on risks/problems still applies, as it will be even more difficult to accommodate the required space.

**3.12.3 Issues to be considered**

Issue	Risks to historic/traditional buildings
1. Provision of sanitary facilities and accessible toilets	<ul style="list-style-type: none"> <li>• In conversions where toilets and bathrooms have to be provided as new spaces it can be difficult to find adequate and appropriate space for them without compromising the main rooms in the building. In particular, the space for the provision of an <i>accessible toilet</i>, accessible from public areas (not en-suite) can be disruptive to the historic character of spaces.</li> </ul>
2. Provision of drainage	<ul style="list-style-type: none"> <li>• It can be very difficult to find a route for a full 100m soil pipe connecting the new water closet to the ground drains whilst avoiding damage to the historic fabric and preserving the appearance of rooms below.</li> </ul>
3. Provision of water supply	<ul style="list-style-type: none"> <li>• Finding a route for hot and cold water supply pipes from the mains entry point and/or remote water heating source whilst avoiding damage to historic fabric and preserving the appearance of rooms adjacent can also be difficult.</li> </ul>
4. Provision of ventilation	<ul style="list-style-type: none"> <li>• Often new toilets and bathrooms have to be inserted into historic buildings in central spaces away from the external walls of the building. Ventilation is then required in addition to that provided by opening windows. Finding an undisruptive route for a ventilation duct for powered extract or for passive ventilation systems can be difficult, particularly for passive ventilation systems where the vent duct/pipe has to rise continually to the open air without any sharp bends.</li> </ul>
5. Maintenance of pipe work	<ul style="list-style-type: none"> <li>• Wherever water is contained in a system of pipes under pressure there is a danger of leaks causing damage to the surrounding fabric. This is particularly acute in historic buildings where much of the internal fabric is timber and is therefore susceptible to rot.</li> </ul>

**3.12.4 Recommendations to meet the standard**

*a) Provision of toilets and bathrooms*

The sanitary facilities required by the standard have to be provided in a separate room or rooms. Careful consideration must be given from the earliest design proposals as to how these rooms can be fitted in so that their provision has the minimum impact on the historic fabric. Careful attention must be paid to:

- how the facility is to be supplied with hot and cold water and where these supply pipes are to run,
- how the facility is to be supplied with drainage and ventilation,
- how these drainage and ventilation pipes are to be threaded through the existing structure and
- how an accessible toilet can be accessed directly from a public space.

In multi-storey projects, where possible, sanitary facilities should be stacked one above the other so that drainage and water supply pipes can be run through the new facilities with minimum effect on the rest of the building.

Generally the sanitary facilities required by the standards require small spaces. Where one space, big enough to accommodate both bathing and toilet facilities, is not available, a bathroom without water closet can be provided in one small space and a toilet with washbasin provided in another small space.

Often, existing storage cupboards can be used for new sanitary facilities with little damage to the historic fabric. In other buildings the smaller, more humble rooms with least detail should be used. Inserting a bathroom box into the corner of an important historic room should be avoided wherever possible.

*b) Provision of drainage*

The largest pipes are the most difficult to thread through the historic fabric without causing damage. Where it is found impossible to find an acceptable route for a full 100mm soil and vent pipe, a *macerator and pressure pumped system* should be considered. Outlet pipes from these systems need only be small-diameter and, being pumped, can

rise as well as fall. However, the introduction of exposed pipes or ducts on internal surfaces needs to be carefully considered, especially if they have to be routed over and around historic details, such as cornices.

Where it is considered impossible to provide a piped connection to a public sewer at reasonable cost, without unacceptable damage to the historic fabric, the standards allow for the installation of a waterless closet. This standard, strangely, does not make clear what should happen to waste water from baths, showers, wash hand basins and sinks. It must be assumed that waste from these facilities must continue to be taken to a public or private disposal system (refer to Standard 3.7 Wastewater drainage – not covered in this Guide).

#### *c) Provision of Water Supply*

Water supply pipes are generally much easier to thread through the historic fabric due to their small diameter and flexible nature when using modern materials. Care must, however, be taken to ensure that all supply pipes are adequately supported and will not be damaged by any movement in the structure.

Hot water supply pipes should be insulated between heat source and point of delivery. This can increase the overall diameter to three or four times the diameter of the pipe itself, and can exacerbate the difficulties of finding acceptable routes through the historic fabric. Where this proves to be too difficult, *point of delivery water heaters* can be used. These require only a single, small-diameter cold supply and, usually, electric power via a twin and earth cable.

A water supply system is usually pressurised by gravity by installing a cold-water storage tank at the highest point of the building. In many historic buildings this is not possible, either because the space is not available, or because the historic structure is not adequate to bear the weight of this, often very heavy tank, and the water within it. In some areas, the water authority may allow all water supply requirements to be taken directly off the mains for domestic buildings, the required pressure within the building being provided by the pressure in the mains. Where this is allowed, a high-level water tank within the building is not required.

Where a high level tank is not possible, a tank installed in a basement, store or other low-level space should be provided with an electric pressure-pump to lift water to the required point of delivery. Where possible the load of tank and water should be transferred directly to the ground avoiding any stress in the historic fabric.

#### *d) Provision of Ventilation*

Refer to Standard 3.14 for recommended ventilation provision to sanitary accommodation. Standard 3.14 recommends that a bathroom or a shower-room be ventilated by either a mechanical extract system or a passive stack system. A toilet may be ventilated by a ventilator with an opening area of at least 1/30th of the floor area of the space; typically by trickle ventilation in a window or by mechanical ventilation. Most domestic mechanical and passive ventilation systems require ducts of minimum 75mm diameter.

### **3.12.5 Related standards**

Other related standards are:

- Standard 3.5 Existing drains
- Standard 3.7 Wastewater drainage
- Standard 3.14 Ventilation
- Standard 4.2 Access within buildings

### 3.13 Heating

#### Standard 3.13

Every *building* must be designed and *constructed* in such a way that it can be heated.

Limitation

This standard applies only to a *dwelling*.

#### 3.13.1 Type of standard

##### **Mandatory standard**

In the case of *conversions*, the building as *converted* must meet the requirement of this standard.

#### 3.13.2 Commentary

In the conversion of a historic building to dwellings, meeting the requirements of this essential standard will not present any real risks to the character of the building. It is accepted that practically all such conversions will involve the installation of some form of ‘central heating’ system, which will more than meet the minimum standard set out.

Historic buildings of masonry construction will often have internal walls, chimneys, vaults and solid floors that have a high thermal capacity. This thermal capacity may be taken into account when considering the heating system, as their ability to store heat can reduce temperature fluctuations within rooms. Where the external walls are of massive masonry construction and lined internally with lath and plaster, it is sometimes thought that they will act as a thermal store to the benefit of space heating. However, this is not the case as the presence of a ventilated void behind the plaster has the effect of converting the structure into one that is thermally lightweight, which means that the internal surfaces will have only a limited capacity to store heat and will thus respond quickly to changes in temperature.

From May 2007, draft amended standard 3.13 is:

*Every building must be designed and constructed in such a way that it can be heated and maintain temperatures at a level that will not endanger the health of the occupants.*

*Limitation*

*This standard applies only to a dwelling.*

This amendment is used to require a much less basic heating performance, but the guidance on risks/problems remains applicable.

#### 3.13.3 Issues to be considered

Issue	Risks to historic/traditional buildings
1. Heating regimes not matched to building fabric and room arrangements	• Spaces (eg recesses and cupboards) not adequately heated leading to mould growth, condensation and potential fabric deterioration.
2. Heating of previously unheated or poorly heated spaces	• The sudden heating of previously unheated or poorly heated spaces can cause a rapid change in the moisture condition of porous materials; leading to serious shrinkage and cracking (refer to Part 1, Section 4.4 for further information).

#### 3.13.4 Recommendations to meet the standard

The minimum heating requirements set out in this standard, which relates only to dwellings, are very basic and in almost every dwelling created by the conversion of a historic building these requirements will be exceeded significantly. Guidance on ways of heating such buildings efficiently is given in the notes to Standard 6.3. However,

it is important to match the type of heating system to the thermal properties of the building so that the most energy efficient approach is adopted. In addition, the heating of the building should take into account heat losses from ventilation (Standard 3.14) and the need to ensure that surface temperatures normally exceed dew point temperatures for the moisture vapour conditions likely to prevail.

A balance is required between heating of spaces, surface temperatures and ventilation to prevent mould growth. This is likely to be more problematic in recesses and cupboards on external walls (refer to notes in Section 3.15). Unless particular care is taken in the design of space heating it is possible, even when recommended room temperatures are achieved, that there are spaces within or adjacent to rooms where the internal air temperature falls below the critical temperature at which mould growths can occur.

It is normal for a dwelling to be continuously heated, whereas a building that is not continuously occupied, such as a church, will tend to be heated intermittently. Maximising the thermal capacity of the internal fabric will help mitigate fluctuations in external temperature and even out the internal temperature.

With careful design the high thermal capacity volumes of historic fabric can be used as heat-sinks to improve the economics of heating input and to improve the internal environment. These internal volumes of historic fabric should not be insulated, allowing space heating to gradually warm them up and allowing them to re-radiate their stored energy into rooms when these are cooler.

### 3.13.5 Related standards

Other related standards are:

- Standard 3.14 Ventilation
- Standard 3.15 Condensation
- Standard 6.2 Building envelope insulation
- Standard 6.3 Heating systems

## 3.14 Ventilation

### Standard 3.14

Every *building* must be designed and *constructed* in such a way that the air quality inside the *building* is not a threat to the health of the occupants or the capability of the *building* to resist moisture, decay or infestation.

#### 3.14.1 Type of standard

##### **Mandatory standard**

In the case of *conversions*, the *building* as *converted* must meet the requirement of this standard.

#### 3.14.2 Commentary

Lack of ventilation in historic buildings is not normally a problem. The nature of these buildings means that there are many sources of fortuitous natural ventilation, for example through gaps around loose-fitting doors and windows, through skirting and floor junctions, and through roofs and open flues. Such high rates of ventilation usually meant that these buildings were healthy for occupants (if cold) and that condensation and mould growth were controlled. In the conversion of these buildings there is a danger that, by trying to improve energy efficiency, natural ventilation will be reduced to below acceptable levels.

This standard is essentially aimed at the ventilation of bathrooms, kitchens and other moisture-producing areas. In upgrading thermal performance of historic buildings, considerable care has to be exercised when selecting a ventilation rate. A minimum ventilation rate that is acceptable for human health and the extraction of moisture may



be insufficient to provide ventilation to hidden spaces, which could lead to raised moisture contents in vulnerable materials, such as plaster and timber. Ventilation is thus necessary to maintain a healthy building fabric as well as healthy conditions for occupants. The introduction of vapour checks when insulation is added will further reduce the permeability of the construction. However, for traditional Scottish masonry construction the amount of air movement required to maintain a moisture balance and to prevent the development of dry rot in timber is relatively low.

To prevent the occurrence of condensation and mould growth on surfaces it is important to ensure that humidity levels are kept below 70% RH by a combination of both adequate ventilation and space heating.

### 3.14.3 Issues to be considered

Issue	Risks to historic/traditional buildings
1. Control of humidity	<ul style="list-style-type: none"> <li>• Historic buildings with a poorly insulated envelope require a higher internal air temperature than well-insulated construction to keep the air in contact with external wall surfaces below 70% RH (above 70% RH moulds may develop). Note: where the room air is at 70% RH, air in contact with external surfaces will be at a higher relative humidity.</li> </ul>
2. Natural ventilation	<ul style="list-style-type: none"> <li>• Sealing up openings (draught stripping) and open flues to conserve energy reduces airflow within rooms and hidden spaces and may upset the moisture balance in porous materials and promote decay.</li> </ul>
3. Trickle ventilators	<ul style="list-style-type: none"> <li>• Unsympathetic introduction of trickle ventilators into traditional sash and case windows (and other traditional windows) may adversely affect the historic character of the windows.</li> </ul>
4. Passive stack ventilation systems, mechanical ventilation and mechanical aids to ventilation	<ul style="list-style-type: none"> <li>• PSV and ducted forms of mechanical ventilation can be very disruptive to historic fabric and its character where ducts intrude into spaces and pass through walls, floors and roofs.</li> <li>• Location of vents in the external fabric (walls and roofs) may affect historic character and their installation can be destructive to fabric, particularly in earth and rubble-type walls.</li> <li>• Location of plant can be visually intrusive and may overload structural elements.</li> <li>• Location and design of controls may be intrusive in sensitive spaces.</li> <li>• A PSV system in a building can be ineffective where wind suction is insufficient to prevent moisture build-up in spaces.</li> </ul>
6. Air movement in voids	<ul style="list-style-type: none"> <li>• May be affected adversely by energy conservation measures that reduce air infiltration – installed ventilation systems may not address this issue.</li> </ul>

### 3.14.4 Recommendations to meet the standard

Wherever possible the natural ventilation system of the historic building should be preserved, with materials and constructions introduced to improve thermal performance being carefully positioned (and held in place) to avoid blocking existing ventilation routes and systems. For example:

- insulation blocking eaves vents;
- insulation blocking the open spaces behind framed-out walls and roof spaces, or between these open spaces on different floors at floor and wall junctions;
- insulation blocking the connection between floor voids and wall voids;
- membranes or insulation blocking wall vents to floor voids.

There are two common physical problems in relation to the normal provisions for ventilation that are encountered in historic building conversions:

- The first is that it can be difficult to incorporate trickle ventilators in existing windows (or to provide them elsewhere). For some historic buildings any alteration to the window joinery will be unacceptable because of the historic importance of that joinery. In these cases the insertion of ventilators in plain plasterwork and through external walls may be preferable. Where some alteration of the window joinery is considered acceptable, trickle vents can be created by cutting holes into the case above the lower sash and below the upper sash as indicated in Illus 3.14.1. Alternatively, if trickle ventilation is required at the top of the window, the system shown in the illustration can be adopted. Fitting proprietary trickle vents in the rails of the sash

is not recommended as this is likely to weaken the joinery sections and the ventilator can look obtrusive. Further information on the installation of trickle ventilators can be found in Newsom (2002).

- b) The second is that sometimes it is not possible to provide the normal natural ventilation opening area via windows, the position and size of these being fixed by the historic façade. The practicality of using openable windows also depends upon the location of the building and the immediate external environment. In noisy or polluted urban areas, for example, it may not be possible simply to open windows for increased ventilation.

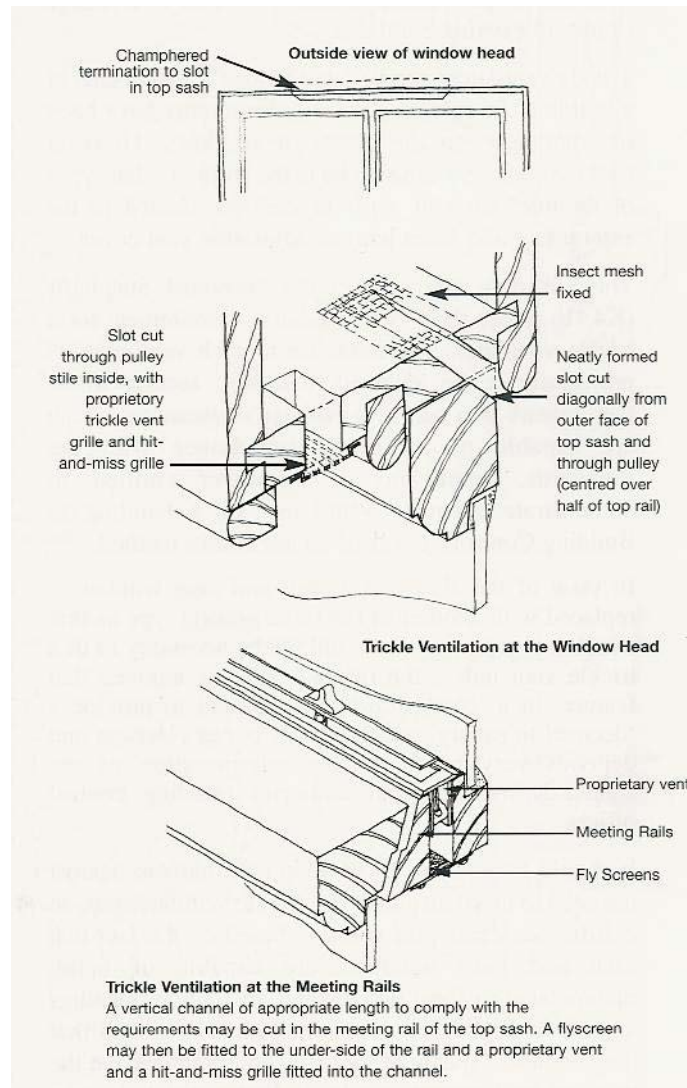

Illus 3.14.1 Detail of trickle ventilation in sash and case window (Reproduced from Historic Scotland, Guide for Practitioners 3 2002).

For dwellings, a number of ventilation options are available, each with its advantages and disadvantages. Reference should be made also to the DTER *Good Practice Guide 268* for more detailed information. The systems available are:

- passive stack ventilation (PSV)
- local extract fans (extract only)
- continuous mechanical ventilation system
  - extract only system or
  - balanced supply and extract system

a) *Passive and mixed mode systems.*

If openable windows alone are insufficient or inappropriate for ventilation in larger-scale commercial buildings then other forms of natural ventilation can be considered. Generally these will rely on creating other ventilation openings in the building, and ducting air from these openings into the spaces. These ventilation openings will often be at roof level to avoid pollution, noise, and to minimise interference with the historic fabric.

These installations may work on a purely ‘passive’ basis, relying upon the natural forces created by wind movements and temperature differences to draw fresh air into the building and then up an exhaust stack to discharge at roof level. Such an installation is referred to as the **passive stack ventilation system (PSV)**, which can also be used in domestic-scale buildings. If there are periods during which these natural forces are not adequate to generate the necessary air movement, fans can be installed at the head of the exhaust stack to draw the air through the system. This is what is termed a **mixed mode system**. Mixed mode systems utilise comparatively low fan power, and then only when fan assistance is required, and so can assist in achieving the requirements under Standard 6.6, which relate to the efficiency of mechanical ventilation systems.

Passive or mixed mode ventilation systems require complex calculations and usually dynamic thermal modelling to ensure that they will work correctly, thus suitably qualified engineers would be required to prepare the designs. Complex historic buildings, even if simple ventilation systems are to be used, will normally require specialist engineering input.

It is recommended that the use of the PSV system be considered as the first choice of system for a historic building. It is only when the suction generated by a PSV system is insufficient that a mechanical system should be installed.

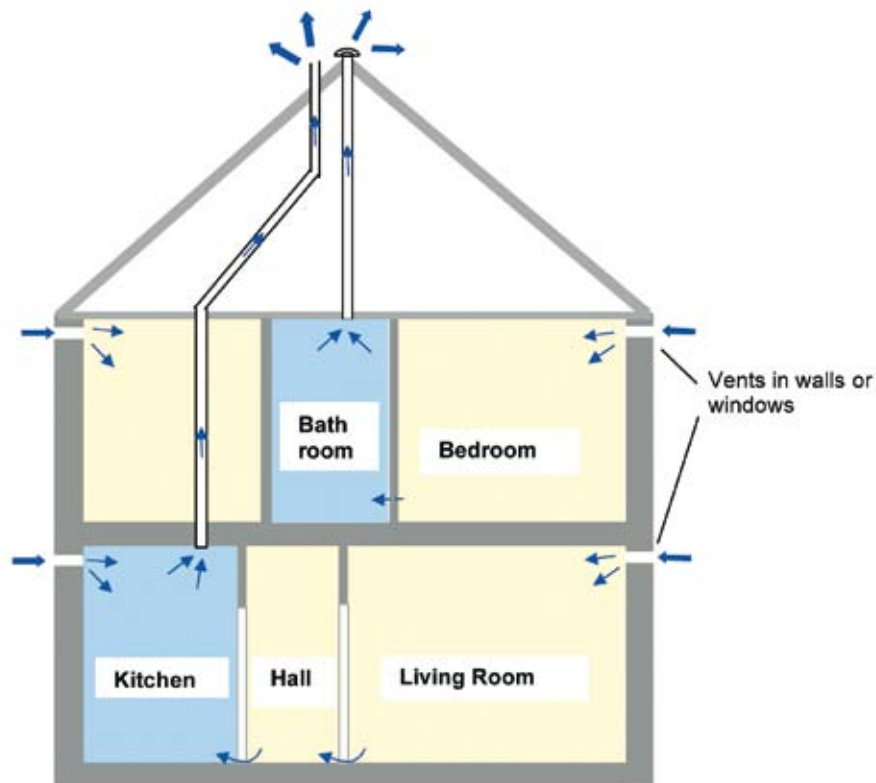

*Illus 3.14.2 Whole-house ventilation – domestic passive stack ventilation system.*

b) Local extract fans

Local extract fans are positioned in the high moisture producing spaces to extract moisture and other pollutants. They are not normally operated continuously and may be operated by the occupant or by a humidity-sensor control (sited close to the main source of moisture generation) with replacement air provided by trickle ventilation. The extracted air is ducted to the outside and the positioning of the extracts needs to be carefully controlled to avoid damage to historic character and to prevent drawing combustion gases into a room from open-flued appliances.

c) Continuous mechanical ventilation system

In dwellings or domestic-scale properties, a good, practical and energy efficient solution is to install a continuous mechanical ventilation system complying with the provisions of BRE Digest 398. There are two main forms of such systems:

- i. extract only and
- ii. balanced supply and extract.

Both can be designed to comply with the Building Standards using proprietary equipment for small-scale applications.

The **extract only system** relies upon leakage into the building for make-up air. Generally in historic buildings with sash and case windows, the infiltration through these windows will be adequate for such a system to function properly, *provided that excessive draught stripping has not been fixed to the windows*. It is important to ensure that sufficient air infiltration will be available from other sources in such cases.

The **balanced supply and extract system** delivers air as well as extracting it and does not rely on any infiltration. The balanced supply and extract type of system can also be provided with a cross-flow heat exchanger to recuperate some of the heat from the exhaust air and pre-heat the incoming fresh air. These systems contribute to the energy efficiency of the building and can help with the energy performance requirements under Section 6.6, but additional space is required for the plant involved.

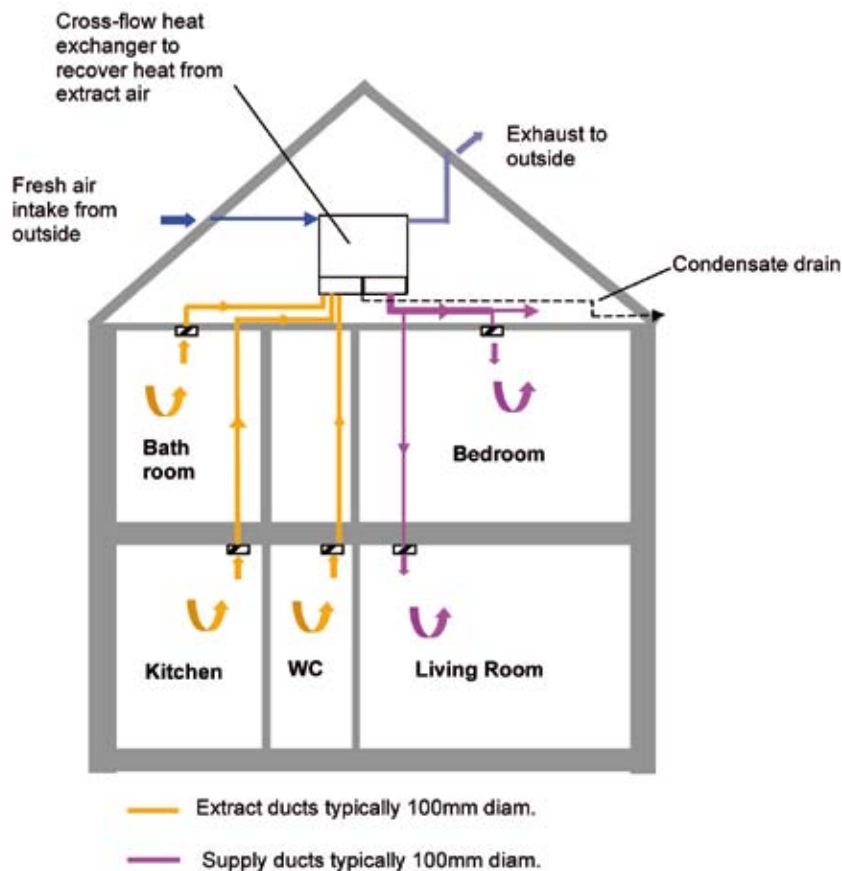

Illus 3.14.3 Balanced supply and extract whole-house mechanical ventilation system with heat recovery.

Both systems require a location for one or more (in larger properties) central fan units, which will be ducted to outside: one duct for the extract only system and two for the balanced supply and extract system. The size of these ducts depends upon a number of factors, which require calculation, but typically they would be around 150mm to 200mm diameter in proprietary systems. The routing of ducts must be carefully designed to reduce damage to historic fabric and need to have appropriate fire stopping and sound insulation (for dwellings) at penetrations in separating floors and walls. These systems offer a number of advantages over discreet extract or supply fans. A typical small building might require three or four individual fans for toilets, kitchens and the like alone. Each of these fans requires a wall or roof penetration.

A **central continuous system** can achieve the same or better standard of ventilation with one or two penetrations, which can be located in such a way as to minimise interventions with the fabric and provide the best location for the air intake or exhaust in relation to the surrounding environment. These systems are also typically quieter in operation and less visually intrusive.

Many historic buildings, from which air is being mechanically extracted, will allow sufficient replacement air to infiltrate into the space from an adjacent area around and below existing doors. To comply with the standard for 4000mm<sup>2</sup> of trickle ventilation, additional unobstructed air space can be achieved by such infiltration, provided that this has been accurately determined and is capable of being inserted into the existing construction. This does not necessarily have to be provided by way of holes in the door. Cutting 5mm off the bottom of a standard 824mm door will provide 4000mm<sup>2</sup> of ventilation space for replacement air to pass through.

*Ventilation outlets through roofs*

The introduction of roof vents into historic roofs needs to be carefully considered and designed. How this is achieved depends on the importance of the building and, particularly, of the roof and roofscape. Among the factors to be considered are:

- outer, visible roof slopes should be avoided for any ventilation outlets;
- often historic buildings have hidden valleys and roof slopes where roof vents will have a minimal impact;
- hidden, simple ‘straight-through’ vent pipes with carefully formed lead collars (rather than short-life, tin rubber collars) should be considered;
- where a larger free ventilation area is required, small additional pitched dormer-vents can often be incorporated (Illus 3.14.4);
- inset-dormer vents are usually less obtrusive than projecting dormer vents (Illus 3.14.4);

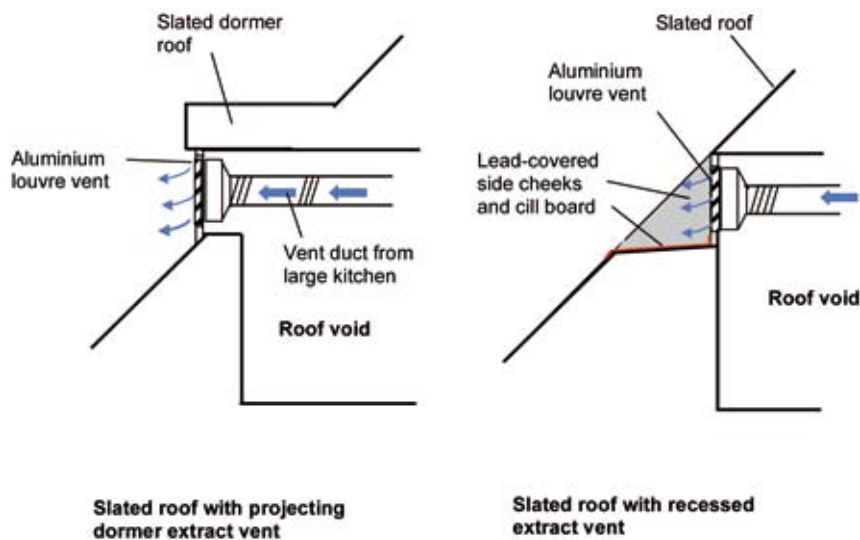

*Illus 3.14.4 Projecting and inset dormer vents – inset (recessed) vents are preferred).*

- where the vent is to be positioned onto a visible roof slope, a proprietary flush-with-pitch plastic or metal vent can be used (Illus 3.14.5);
- other types of roof vents may be used depending on circumstances, eg ridge vents (raised fireclay, raised ridge roll and lead flashings) and continuous lead or zinc.



*Illus 3.14.5 Inset dormer vents on a traditional pitched slated roof. Inset dormer vents eliminate the need for large, intrusive ventilation grills.*

### **3.14.5 Related standards**

Other related standards are:

- Standard 3.13 Heating
- Standard 3.15 Condensation
- Standard 5.1 Resistance to noise transmission (through ducts)
- Standard 6.2 Heating systems
- Standard 6.6 Mechanical ventilation and air conditioning



*Illus 3.14.6 Flush roof vents (Photo: D Urquhart).*

### 3.15 Condensation

#### Standard 3.15

Every *building* must be designed and *constructed* in such a way that there will not be a threat to the *building* or the health of the occupants as a result of moisture caused by surface or interstitial condensation.

#### Limitation

This standard only applies to a *dwelling*.

#### 3.15.1 Type of standard

##### *Reasonably practicable standard*

Every *conversion*, to which these regulations apply, must be improved to as close to the requirement of the standard as is *reasonably practicable*, and in no case be worse than before the *conversion*.

#### 3.15.2 Commentary

While this regulation applies only to dwellings, the risk of damage to the fabric of a traditional building as a result of condensation is such that it must be treated as an issue for all buildings. It contains no specific controls but instead, generalised objectives and directs the reader to two principal sources of guidance:

- BS 5250:2002 *Code of Practice for the Control of Condensation in Buildings*
- Stirling (2002), *Thermal Insulation: avoiding risks*

Both of these documents are aimed at the designers of new buildings, but include guidance on the important principles that must also be observed in the conversion of traditional buildings.

When addressing the problem of condensation in historic buildings it is of critical importance to consider the whole building envelope and its servicing. The main principles of condensation control in new buildings rely upon thermal isolation (avoidance of cold bridging), vapour control (vapour checks, vapour barriers and breather membranes) and extraction (mechanical ventilation in bathrooms and kitchens). In traditional methods of construction, the emphasis is largely upon natural ventilation, heating, and controlled condensation.

The combination in many historic buildings of ventilated timber floors, lath and plaster walls with air spaces behind, uninsulated freely ventilated roofs, single glazed windows and open fires in every apartment, may not be thermally efficient, but it does provide an effective solution to the risks of condensation. Traditional slated roofs often did not include felt membranes under the slates, which were nailed directly to gap-boarded sarking, and, as a result, allowed air to penetrate freely into the roof space. Alteration to any element of such a construction (usually to improve the level of thermal comfort) can have serious and unexpected consequences with regard to condensation risk.

Two fundamental approaches exist in dealing with condensation in historic buildings:

- a) Where the fabric of the building is such that it is desirable to retain or re-create the internal linings, every effort should be made to enable the building to continue to work or breathe in the way that it always has. This requires that the construction is well ventilated, that no existing ventilation paths are blocked and mechanical extraction is located as close as possible to any new sources of moisture such as showers, baths, and hobs.
- b) In instances where the building does not have, or has never had, any internal linings, there is greater opportunity to treat it in the manner that a new construction would be detailed, with the provision of vapour control layers, and unbroken or bridged insulation.

The potential for interstitial condensation within the construction of a traditional building is an issue that requires careful attention. Unlike new buildings, which have vapour checks built into the construction to control the movement of water vapour into the fabric, traditional buildings have porous surfaces that offer little resistance to the transfer of water vapour. To prevent the occurrence of condensation within the construction, reliance is placed on keeping hidden voids and roof spaces ventilated to control humidity levels.

In dealing with condensation it is also important to recognise the role of mould growth. This standard covers the threat to the health of occupants; mould spores may affect health, especially of persons suffering from asthma or allergies. While surface condensation will occur when the surface temperature falls below the dew-point temperature of the ambient air, mould growth can occur on a surface that is above dew-point temperature. This becomes more of a problem where the walls of a traditional building have not been thermally upgraded, and internal surface temperatures remain depressed. Sealing up the building to improve energy efficiency may reduce ventilation rates and raise humidity levels above the critical point for mould growth.

### 3.15.3 Issues to be considered

Issue	Risks to historic/traditional buildings
1. Condensation in roofs	The risks are: <ul style="list-style-type: none"> <li>• Lack of ventilation can lead to increased risk of condensation in the roofspace and consequential problems of rot and mould growth.</li> <li>• Condensation on slate fixing nails can lead to corrosion and failure.</li> <li>• Installation of roof ventilators can affect the appearance and character of the roof.</li> <li>• Installation of roofing felt during previous remedial works can severely restrict the level of fortuitous ventilation within the roof space, requiring the provision of roof vents.</li> <li>• Provision of a vented cavity may require removal of historic finishes in flat roofs and raise the level of the roof line.</li> <li>• Underside lead corrosion can occur to existing and new lead roofing.</li> </ul>
2. Surface condensation and thermal bridging	Condensation associated with single glazed windows and window jambs. <ul style="list-style-type: none"> <li>• Replacement double glazed windows may change the character and appearance of the building to an unacceptable degree and move condensation elsewhere.</li> <li>• Secondary glazing may have an equally unacceptable impact upon the interior.</li> <li>• Condensation on windows and jambs can cause rot in windows and damage to internal finishes on walls and floors.</li> <li>• Trickle ventilators can be visually obtrusive in more sensitive historic buildings.</li> </ul> Condensation on walls and fittings in areas of high humidity. <ul style="list-style-type: none"> <li>• Poorly ventilated bathrooms and kitchens can lead to surface condensation on walls which will lead to deterioration of both finishes and the historic fabric of the walls. Also condensation dripping from cisterns can have an equally damaging effect upon floors.</li> <li>• Mechanical ventilator locations and proliferation can be visually obtrusive if handled insensitively.</li> </ul>
3. Interstitial condensation	<ul style="list-style-type: none"> <li>• Where interstitial condensation forms within the fabric of a traditional wall construction, it will have its most severe impact where construction timbers are built into the external stone wall.</li> <li>• Timber lintels and joist ends are liable to absorb any condensation forming on and tracking down the inner face of the outer stone leaf.</li> <li>• Care is required to interpret correctly the source of moisture and ensure that moisture from poor maintenance (pointing, rain water gutters etc.) is not confused with interstitial condensation.</li> <li>• Incomplete thermal insulation and vapour checks, eg at window sills and ingoes, may encourage interstitial condensation on colder surfaces.</li> </ul>

### 3.15.4 Recommendations to meet the standard

The issue of condensation, and more particularly interstitial condensation, is one where alterations to improve for example thermal performance, fire or sound insulation, can lead to a building's performance being worse than before the conversion. While the following diagrams and descriptions offer solutions to some specific problems, it is essential that a holistic approach is taken, with a consistent overall strategy being adopted.

Note: Most of the diagrams in this section are composite details, which relate to more than just Standard 3.15 Condensation. They are therefore repeated in other sections of the Guide where appropriate, for example in Section 6 Energy.



a) *Condensation in roofs*

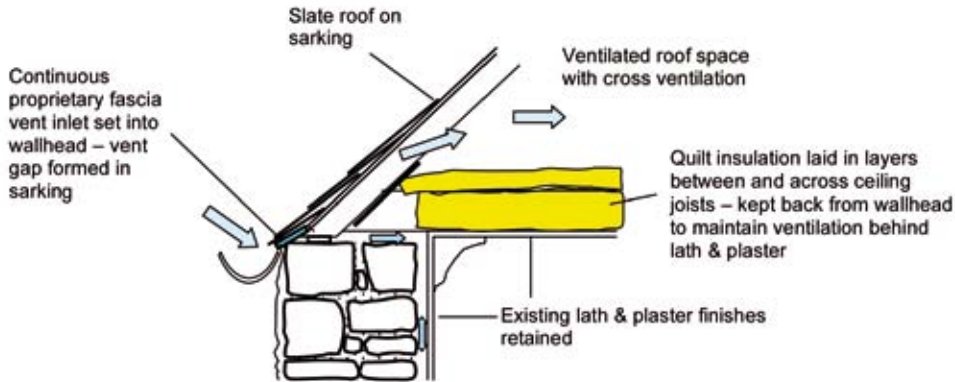

Illus 3.15.1(a) *Eaves ventilation of insulated pitched roof.*

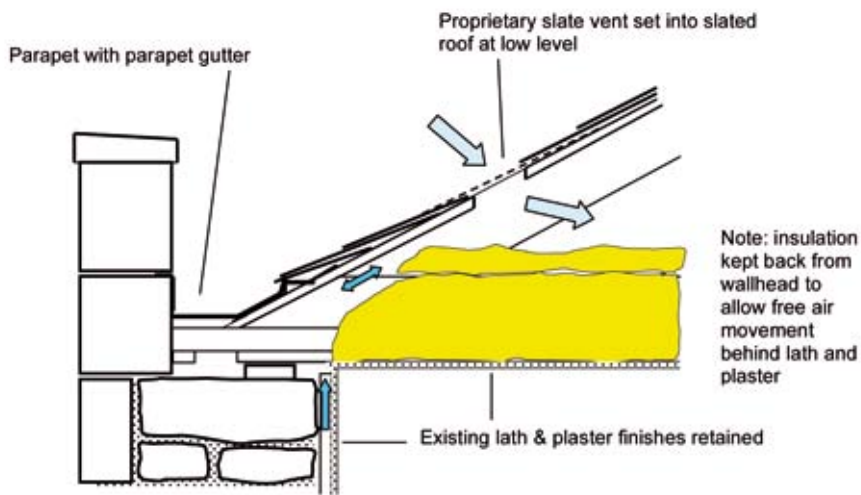

**Parapet wallhead detail with ceiling insulation**

Illus 3.15.1(b) *Roof ventilation using proprietary slate vents.*

Notes

- i. Continuous ventilation, or equivalent, is essential at eaves level and commonly required at the ridge.
- ii. A traditional uninsulated roof will permit free movement of air between the roof space and behind the lath and plaster. However, adding insulation that seals off the top of the gap at the plaster, while satisfying the requirement of Standard 2.4.1, compromises the free flow of ventilation; there is thus a need to ensure adequate air movement by other means. In this example, the insulation is kept back from the wallhead to allow free movement of air between the void behind the lath and plaster and the roof space.
- iii. Due to the temperature differential between the wall and ceiling plaster (especially at the wall head), there is an increased risk of both surface and interstitial condensation on the wall at its junction with the ceiling. Careful control of relative humidity and vapour pressure within room spaces is therefore a vital factor in the control of condensation.

- iv. Loft insulation should be of a material not susceptible to damage from condensation dripping from nail ends.
- v. All pipework and tanks should be on the warm side of the insulation wherever possible.
- vi. Design of roof ventilators should be sympathetic to the historic character of the roof.

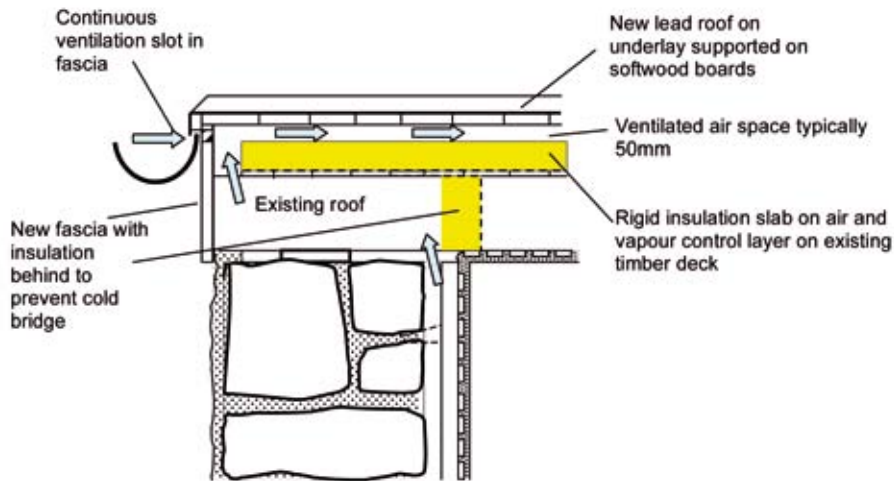

*Illus 3.15.2(a) Ventilation of flat roof using a ventilated space above the original roof deck to combat underside lead corrosion (ULC). New lead roof covering and supporting deck constructed.*

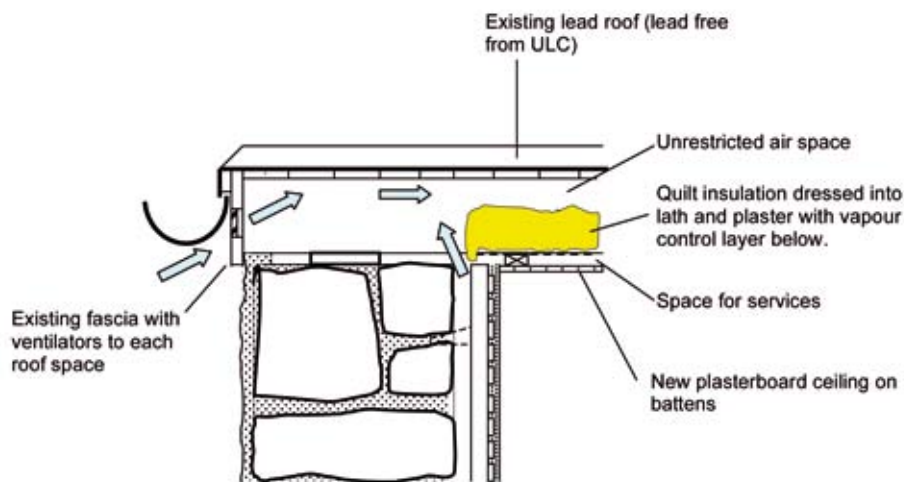

*Illus 3.15.2(b) Ventilation of existing lead covered flat cold roof. Existing ceiling removed to allow installation of insulation and vapour check.*

Notes

- i. Refer to notes for Illus 3.15.1 for the problem of maintaining ventilation behind lath and plaster.
- ii. For existing and new lead roofs, underside lead corrosion (ULC) can reduce significantly the life of lead sheeting. Ventilation of the roof below the lead supporting deck is essential to control this phenomenon. Where the existing ceiling must be retained, Illus 3.15.2(a) offers an appropriate solution, however, it requires the level of the lead roof covering to be raised.
- iii. Illus 3.15.2(b) shows a cold roof solution where the existing ceiling is removed to allow installation of insulation and a vapour control layer. This solution is also appropriate for control of ULC.

*b) Condensation on or within floors*

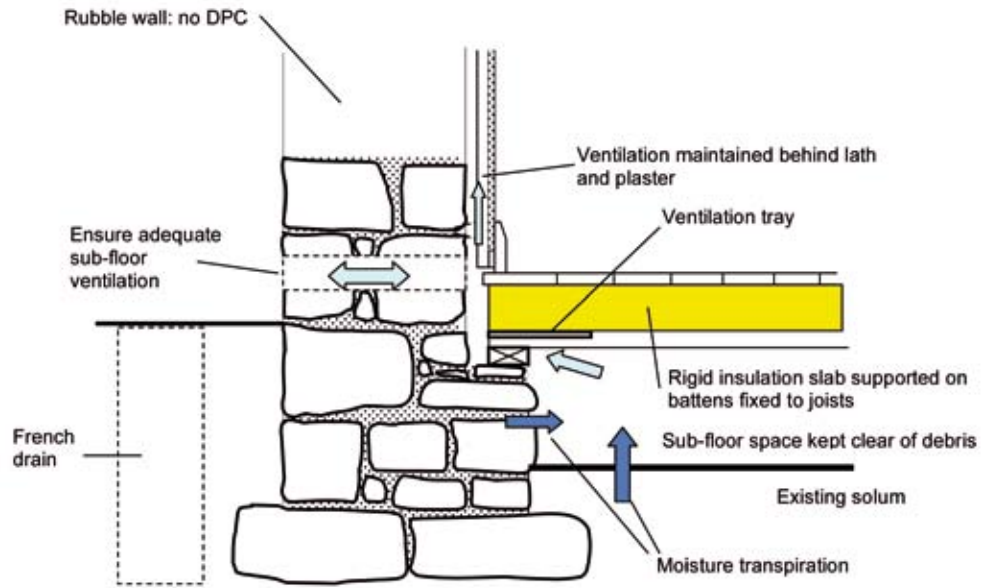

*Illus 3.15.3(a) Ventilation of suspended timber floor with ventilation behind lath and plaster.*

Notes (refer also to notes associated with Standard 3.4, Moisture from the ground)

- i. Solum ventilation must be maintained and, where possible or required, enhanced. Continuity with the cavity behind the lath and plaster should be achieved by ensuring the floor insulation does not seal off the ventilation paths to the void behind the lath and plaster.
- ii. Where vertical separating construction is inserted through the building, continuity of the solum ventilation will need to be provided, including the provision of fire sleeves.

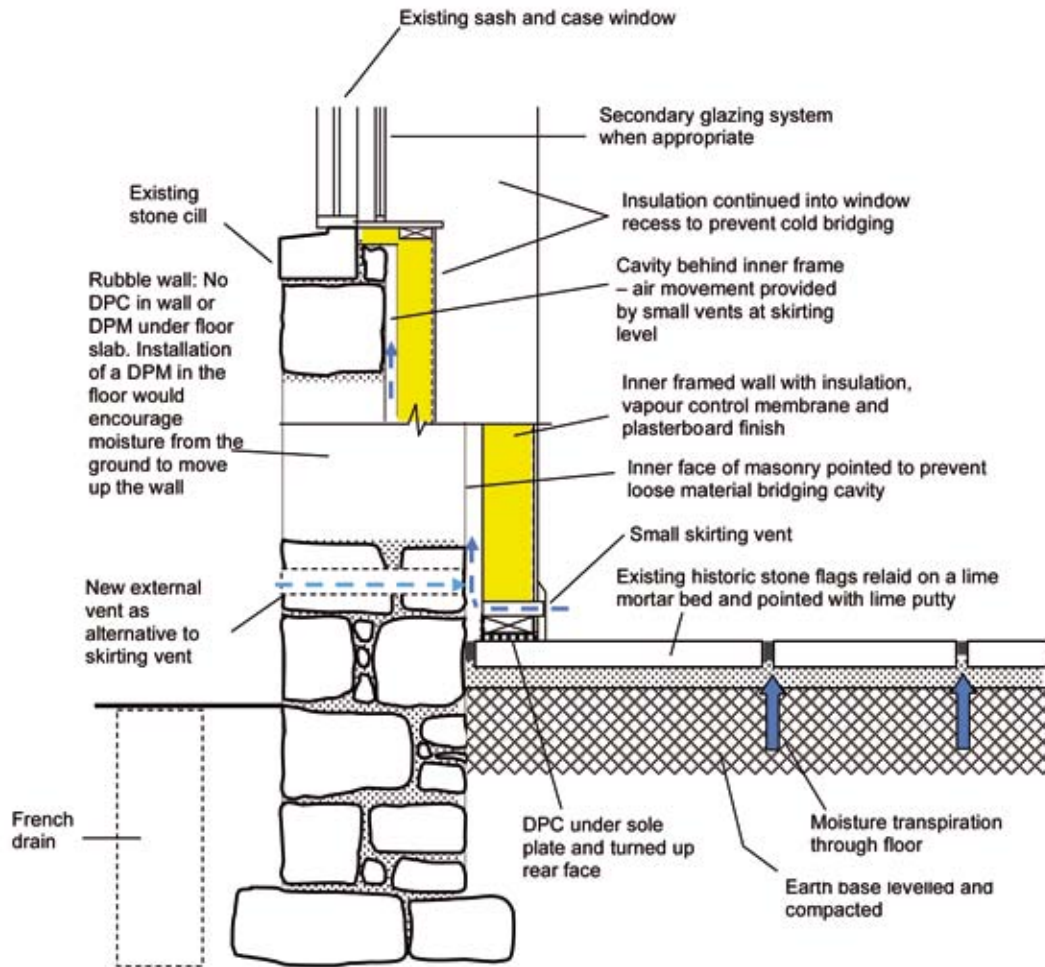

Illus 3.15.3(b) Recommended solution where an existing flagstone floor is retained.

Notes (refer also to notes associated with Standard 3.4 Moisture from the ground)

- i. A solid floor of the type illustrated, where the historic form of construction has to be retained, will be prone to surface condensation where the rest of the envelope has been improved. Timber should be isolated from the floor surface to reduce contact with surface moisture. Efficient room ventilation is essential to control relative humidity and vapour pressure.
- ii. In this example the insulation of the external wall has been improved. However, adding insulation is only appropriate in historic buildings when there are no existing wall finishes of historic significance. Lath and plaster is a historic finish and the presumption should be to retain such finishes whenever possible.

c) *Condensation within walls*

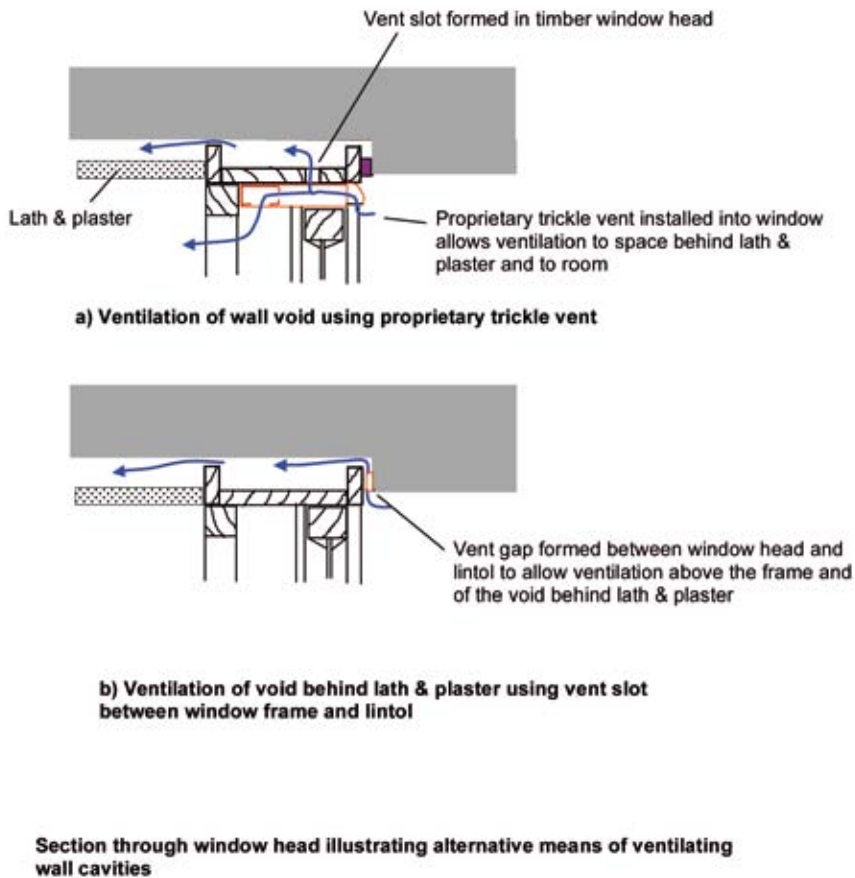

*Illus 3.15.4 Window head detail providing supplementary ventilation to cavity behind lath and plaster wall finish.*

Notes

- i. Maintenance of the void behind the lath and plaster will allow for improved evaporation of interstitial condensation on the inner face of the outer stone wall. Given the restrictions created by Standard 2.4.1, as mentioned in Section 3.15.4(a) ii above, it may be necessary to provide alternative means of ventilation to this space.
- ii. Providing air movement within the space behind wall finishes to control the moisture content of adjacent timbers and plaster is not easily achieved where there are separating floors between dwellings. Illustration 3.15.5 shows a possible means of achieving air movement by the insertion of inconspicuous, small-area vents at skirting and ceiling level. Because of the danger of drawing moisture laden air into the cooler void behind the plaster, the vents should not be installed in moisture producing spaces, such as kitchens and bathrooms.

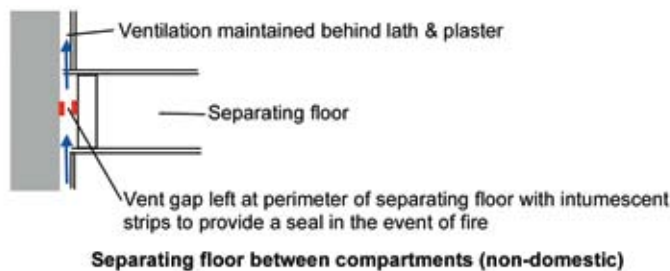
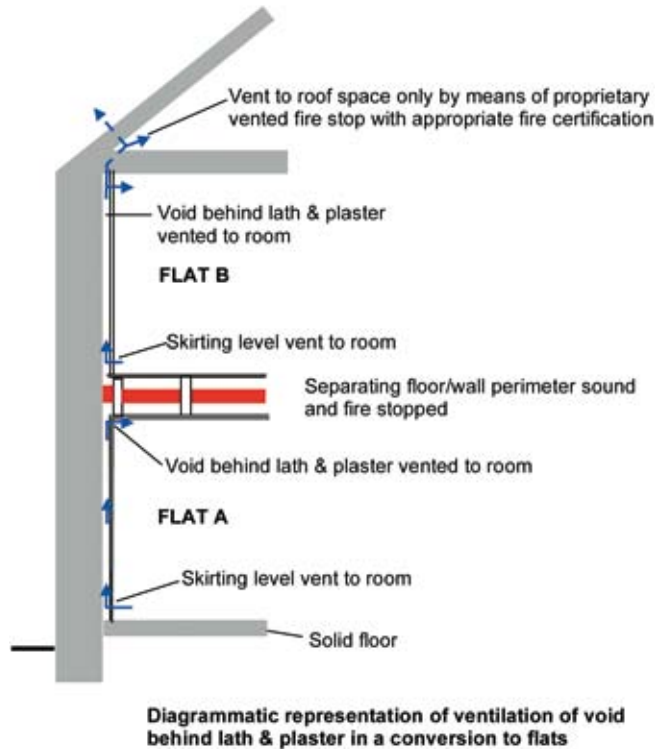

Illus 3.15.5 Ventilation of void behind wall finishes where separating floor wall junctions are sealed for fire resistance and sound insulation.

**d) Condensation on single glazed windows**

Notes

- i. Where single glazed windows are to be retained or reinstated, a condensation drain should be provided where possible and particularly in areas of high humidity or with a northerly aspect.
- ii. Draught stripping of sash and case windows will dramatically reduce ventilation rates and necessitate the provision of passive or trickle ventilation, which may be difficult to incorporate into a traditional window frame. Suitable details for providing trickle ventilators in sash and case windows are shown in Illus 3.14.1.
- iii. Improving the envelope insulation elsewhere and incorporating vapour control barriers will tend to increase the risk of surface condensation on single-glazed windows.

**e) Thermal bridging**

Improving the insulation to parts of the envelope of a traditional building, and sealing up gaps in the construction to reduce infiltration, will increase the risk of condensation through thermal bridging at locations where insulation is not provided (and vapour control layers have not been installed). Situations where condensation is allowed to form (and is not evaporated) in materials in contact with embedded timber are areas of increased risk of material decay.

Examples of such situations where surface condensation, interstitial condensation and moulds may occur are:

- window and cupboard recesses,
- on and below window sills,
- external door threshold areas,
- lintels (timber safe-lintels are at particular risk),
- uninsulated floor wall junctions,
- junction of insulated roof with poorly-insulated walls.

Steps should be taken to ensure sufficient air movement at these locations to control humidity levels and to prevent stagnation.

### **3.15.5 Related standards**

Other related standards are:

- Standard 2.4 Fire spread in cavities (i.e. sealing of cavities)
- Standard 3.10 Precipitation
- Standard 3.13 Heating
- Standard 3.14 Ventilation
- Standard 6.2 Building insulation envelope
- Standard 5.1 Noise (ie sealing of cavities)
- Standard 6.3 Heating systems

## **3.16 Natural lighting**

### **Standard 3.16**

Every *building* must be designed and *constructed* in such a way that natural lighting is provided to ensure that the health of the occupants is not threatened.

Limitation

This standard only applies to a *dwelling*.

### **3.16.1 Type of standard**

#### ***Reasonably practicable standard***

Every *conversion*, to which these regulations apply, must be improved to as close to the requirement of the standard as is *reasonably practicable*, and in no case be worse than before the *conversion*.

### **3.16.2 Commentary**

This standard applies to dwellings, and only to *apartments* within the dwellings. Therefore a space that is designated as a store or box room need not comply with this standard.

It is unlikely that the application of this standard in the conversion of a historic building will present any significant risk to the fabric or character of the building, as the minimum requirements for natural lighting can be readily achieved in most buildings. The exception is when new openings for natural lighting are inserted into the existing fabric.

**3.16.3 Issues to be considered**

Issue	Risks to historic/traditional buildings
Natural lighting provision	<ul style="list-style-type: none"> <li>• New window openings to rooms, whether through walls or in the roof, have the potential to cause a significant loss of historic character if they are poorly designed, badly integrated into the envelope or use inappropriate materials.</li> </ul>

**3.16.4 Recommendations to meet the standard**

The daylight requirement of this standard can be achieved by means other than a window. Alternative means of providing natural lighting can be by means of:

- rooflight,
- glazed roof,
- glazed door and
- glass bricks.

All the areas of natural lighting can be aggregated to provide the total area required.

The conversion of a historic building is required to meet the requirements of the standard to as close as is reasonably practicable and in no case worse than before. However, it is often the case that the windows of a historic building cannot be altered to allow the room to be designated as an apartment. In such cases it may be possible to redesign the space to reduce its size to ensure compliance, which is not always practicable, or to combine spaces into an open-plan area to permit an aggregation of daylight provision to meet the required standard. These are likely to be exceptional cases as an apartment can be as small as circa 6m<sup>2</sup>, in which case the glazed area need only be 0.4m<sup>2</sup>.

If an area is to be designated as an apartment, but does not meet the full natural lighting requirement, a solution may be to introduce a sunpipe to allow transmission of light into the space. Sunpipes are not specifically included within the standards and the advice of the Verifier should be sought.

**3.16.5 Related standards**

Other related standards are:

- Standard 3.11 Facilities in a dwelling
- Standard 3.14 Ventilation
- Standard 4.8 Danger from accidents



*Illus 3.16.1 New window frame fixed into resized opening in this former mill converted to apartments. Note the rather poorly executed mortar pointing around the repositioned stone sill.*



### **Preface to Standards 3.18, 3.19 and 3.20: Combustion appliances**

These three standards are concerned with features such as chimneys, flue pipes, the size and design of flues, the location of flue terminals and the relationship of chimneys, flue pipes and appliances to combustible materials. Standards 3.18 and 3.20 are standards that *must be met* in a conversion, while Standard 3.19 is one that *must be met as close to the requirement as is reasonably practicable*. Therefore, in attempting to alter these existing features to comply with the standards, there is a risk that the historic character of the building may be adversely affected.

Original chimneys are important features of historic buildings, and chimneystacks and pots are essential to the character of the roofscape of both individual buildings and groups of buildings. These features should always be retained, and reinstated or repaired where necessary using traditional methods, with particular attention to cope details and profiles. Over the life of a building, original chimney pots are often replaced with pots that are of modern design and thus conflict with the character of the roof. Broken or unsuitable chimney pots should be replaced with ones that match the original or are of a local pattern. Also, chimneys become redundant and are sometimes demolished because of structural problems, or to save on maintenance.

Where possible, the opportunity should be taken to rebuild previously altered or demolished chimneys, using traditional materials that match the original, if this will restore the appearance and character of the building. Sometimes chimneys have been rebuilt using brick with a rendered finish. In exposed rooftop situations, render tends to have a short life and the subsequent condition and appearance of the chimney becomes unacceptable on a historic building. The opportunity should be taken to rebuild the chimney in its original materials (although, sometimes, rebuilding in brick may be acceptable). However, before proceeding with this type of work, it is important to carry out research to ensure that any new build or repair work accurately reflects the original design and materials. Before rebuilding original chimneys, detailed records – photographs and drawings – should be made to ensure accurate reconstruction.

The installation of new flues for modern appliances will be a common requirement and must be designed with sympathy to reflect the character of the building. Modern flues installed either within the building or fixed to an external wall can cause serious damage to fabric and to historic character. Similarly, poorly sited modern flue terminals projecting above the roofline can be unsightly and not in sympathy with the historic nature of the building.

### **3.18 Combustion appliances – protection from products of combustion**

#### **Standard 3.18**

Every *building* must be designed and *constructed* in such a way that any component part of each fixed combustion appliance installation used for the removal of combustion gases will withstand heat generated as a result of its operation without any structural change that would impair the stability or performance of the installation.

#### **3.18.1 Type of standard**

##### ***Mandatory standard***

In the case of *conversions*, the *building as converted* must meet the requirement of this standard.

#### **3.18.2 Commentary**

This mandatory standard is concerned with the ability of chimneys and flues to remove safely the products of combustion, limit the effects of heat on the structural components and prevent the spread of fire into the building. Most historic buildings will contain existing chimneys and flues, which may or may not be in current use. However, it is likely that the structural condition of many of these chimneys and flues will be unknown, and some may have deteriorated to the extent that they will allow the spread of heat, fire and combustion gases into the building. A particular point of weakness occurs in a wall containing multiple flues, where the separating wall between flues can be quite slender (typically only a half brick thick), and where mortar may have been lost from the joints.

Sometimes old flues were lined with ‘parging’, a lime render applied as the chimney was being built. This was often crudely applied and, over the years, may have become detached. Where historic chimneys and flues are to be retained in use it is therefore likely that they will have to be upgraded to meet the requirements of this standard. However, it is not usually a difficult task to upgrade a chimney, provided it has been well maintained and is in a sound structural condition.

As part of the conversion of a historic building, it is essential to conduct a detailed investigation of the condition of all chimneys and flues, not only for their ability to remove the products of combustion but to assess the chimney for its structural stability and resistance to dampness. Dampness is a major cause of problems in chimneys, whether in use or redundant. Moisture combines with sulphates deposited inside the flue as part of the combustion process to form weak acids. The acids thus formed can attack the lime mortar in the parging or in the masonry joints. Moisture levels can build up rapidly in redundant flues where the fireplace has been built up or the chimney head sealed. It is therefore essential to ensure that redundant flues are ventilated at top and bottom.

Dampness in chimneys can be caused by:

- a) The ingress of rain, which can enter directly down the flue and into the building, through defective flashings or through the wall itself due to the wall thickness being too thin or the pointing defective.
- b) Water ingress at the chimney head, where the mortar holding the chimney pot in place (flaunching) has decayed, allowing water to enter the chimney.
- c) Condensation within the flue, especially in tall chimneys.

Redundant flues can be put to positive use as part of the planned ventilation of a converted building. The flue can be utilised to act as ‘passive stack ventilation’, which may compensate for a more tightly sealed building elsewhere. This is thus a good reason to retain redundant flues and to keep them ventilated. A redundant flue can also be used to accommodate soil and vent pipes, and bathroom and kitchen vents, without disruption to other parts of the historic fabric.

As well as issues relating to existing chimneys and flues, a conversion will often require the installation of new combustion appliances that are remote from an existing flue. The construction of new chimneys and flues, particularly modern metal chimneys, can be destructive to internal spaces and historic character when they are installed within the building. The location of a flue terminal requires very careful consideration if the character of the roof is to be retained. Inserting balanced flues for gas appliances through existing walls must also be carefully considered to avoid damage to both the fabric and character of the wall. There is a special risk where a flue is formed in a rubble wall, as the moisture balance in the wall around the flue (especially in the case of tempered-earth mortars) may be affected, leading to excessive shrinkage as the wall dries out. Attaching a chimney to a building externally can have a significant adverse effect on the architectural and historic character of the building, and should be avoided if at all possible.

### 3.18.3 Issues to be considered

Issue	Risks to historic/traditional buildings
1. Redundant chimneys	<ul style="list-style-type: none"> <li>• Removal of redundant masonry chimneys can affect the architectural appearance and historic character of the building.</li> <li>• Sealing up of redundant flues can lead to dampness within the flues and reduce room ventilation.</li> </ul>
2. Dampness	<ul style="list-style-type: none"> <li>• Poorly maintained chimneys can be a significant cause of dampness and structural decay of masonry.</li> </ul>
3. New chimneys and flues	<ul style="list-style-type: none"> <li>• New metal chimneys installed within historic buildings can be destructive to historic fabric and character.</li> <li>• Modern metal chimneys fixed externally to the building can have an adverse impact on the architecture and character of the building.</li> <li>• Poorly sited flue terminals can affect the character of historic roofs.</li> <li>• Inserting flue terminals (balanced flues) through historic walls can affect adversely both the external façade and the wall construction.</li> </ul>

### 3.18.4 Recommendations to meet the standard

Often the only practical way to utilise an existing chimney flue-way in a historic building is to install a flexible metal liner. This addresses most of the problems outlined in the commentary and is a suitable solution for most combustion appliances, from open solid-fuel fires to oil-fired boilers. The diameter and material of the liner must be considered in relation to the type of combustion appliance, and the flue may also have a positive or negative pressure designation depending on the appliance. Generally, the most suitable material is double-skin stainless steel with a positive pressure rating and, provided the correct grade of material is used, such liners would be suitable for multi-fuel applications. BSEN 1856-1 and -1856-2: 2004 give the definitive guidance on this, and specialist flue manufacturers and installers will be able to provide advice based on the requirements of the British Standard.

Installing liners can be problematic. If the masonry flue is in poor condition it may have partially collapsed in places and there may also be local partial obstructions, which narrow the masonry flue-way and so restrict the diameter of the liner that can be installed.

Normal practice is to secure the assistance of a flue specialist to survey the flues by dropping mandrels of different diameters down the flues. If there is an obstruction which effectively blocks the flue or unduly restricts it, then a decision must be made as to whether it is necessary to remove the obstruction. This can be highly invasive, but if it is necessary to make the flue usable it may be, on balance, the correct thing to do if the alternative to using the flue is even more invasive (such as running a new metal flue down the outside of the building).

### 3.18.5 Related standards

Other related standards are:

- Standard 1.1 Structure
- Standard 2.2 Separation
- Standard 2.3 Structural protection
- Standard 2.4 Cavities
- Standard 3.13 Heating
- Standard 3.14 Ventilation
- Standard 3.19 Combustion appliances: relationship to combustion materials
- Standard 3.20 Combustion appliances: removal of products of combustion

## 3.19 Combustion appliances – relationship to combustible materials

### Standard 3.19

Every *building* must be designed and *constructed* in such a way that any component part of each fixed combustion appliance installation will not cause damage to the *building* in which it is installed by radiated, convected or conducted heat or from hot embers expelled from the appliance.

### 3.19.1 Type of standard

#### *Reasonably practicable standard*

Every *conversion*, to which these regulations apply, must be improved to as close to the requirement of the standard as is *reasonably practicable*, and in no case be worse than before the *conversion*.

**3.19.2 Commentary**

Many conversions of historic buildings will incorporate existing chimneys and hearths for combustion appliances, especially solid fuel appliances. These appliances generate considerable heat and, while this is a *reasonably practicable* standard, great care must be exercised to ensure that combustible materials are protected from temperatures sufficiently high to generate a risk of combustion. The greatest risk is to existing timber joists, beams, grounds and dooks (fillets), built in or adjacent to hearths and chimneys. It is not unusual to find existing combustible material incorporated into a building where the minimum separation from the surface surrounding a flue in a masonry chimney, or from the top surface of a constructional heart, is less than the distance specified in the standard. The construction hearth itself, which is likely to be either a concrete or a stone slab, may be less than the required 125mm thickness of non-combustible material.

Where a new hearth for a combustion appliance has to be constructed, this can usually be accommodated without too much disturbance to existing suspended timber floors. However, achieving a minimum air space of 50mm between the underside of a hearth and timber brackets supporting the ceiling may be difficult to achieve without alteration to the ceiling support system. Illustration 3.19.1 identifies some of the potential risks of combustion when existing hearths and flues are retained in use in a conversion.

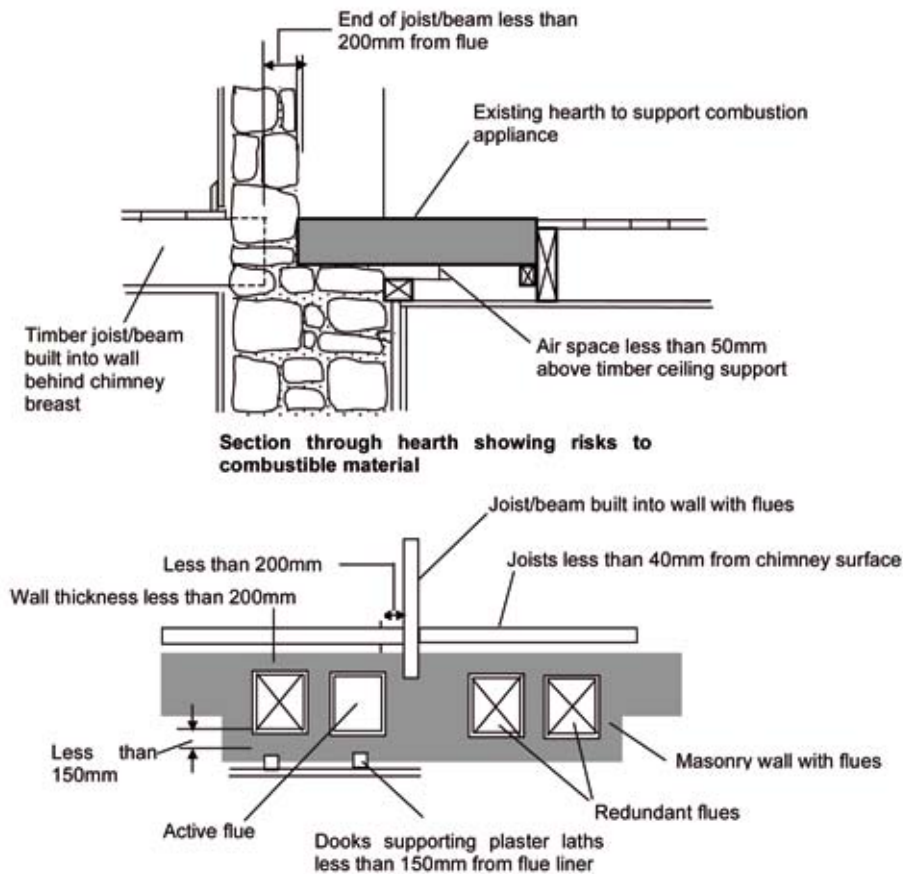

**Section through hearth showing risks to combustible material**

**Plan of wall with multiple flues showing potential risks to combustible material and lack of compliance with the standard (applies only to flues in use)**

**Note: mortar in masonry joints may have deteriorated, increasing the risk of combustion**

*Illus 3.19.1 Diagram showing the potential risks associated with timber built into and adjacent to walls containing hearths and flues.*

When existing flues have to be retained, or brought back into use, it is essential to establish the condition of the masonry walls surrounding the flues. Over time, and with the exposure to heat from the flues, there is a risk that mortar in the joints has deteriorated and become loose, or even been lost from the joint, allowing an easy access route for heat to combustible material. To establish the condition of masonry chimneys will normally require surfaces behind internal finishes to be inspected using a minimally-destructive method, such as endoscopy.

Many historic buildings have walls containing multiple flues. Whether or not some of the flues will be retained or returned to use it is essential to establish the routes and locations of all the flues, for both structural and fire safety reasons. Illustration 3.19.2, which is reproduced from TAN 23 (GBG 2001), *Non-destructive Investigation of Standing Structures*, gives a clear picture of the often complex arrangement of flues within a wall. A variety of techniques may be required to identify the routes of multiple flues in a party wall, including free electromagnetic radiation (FEMR).

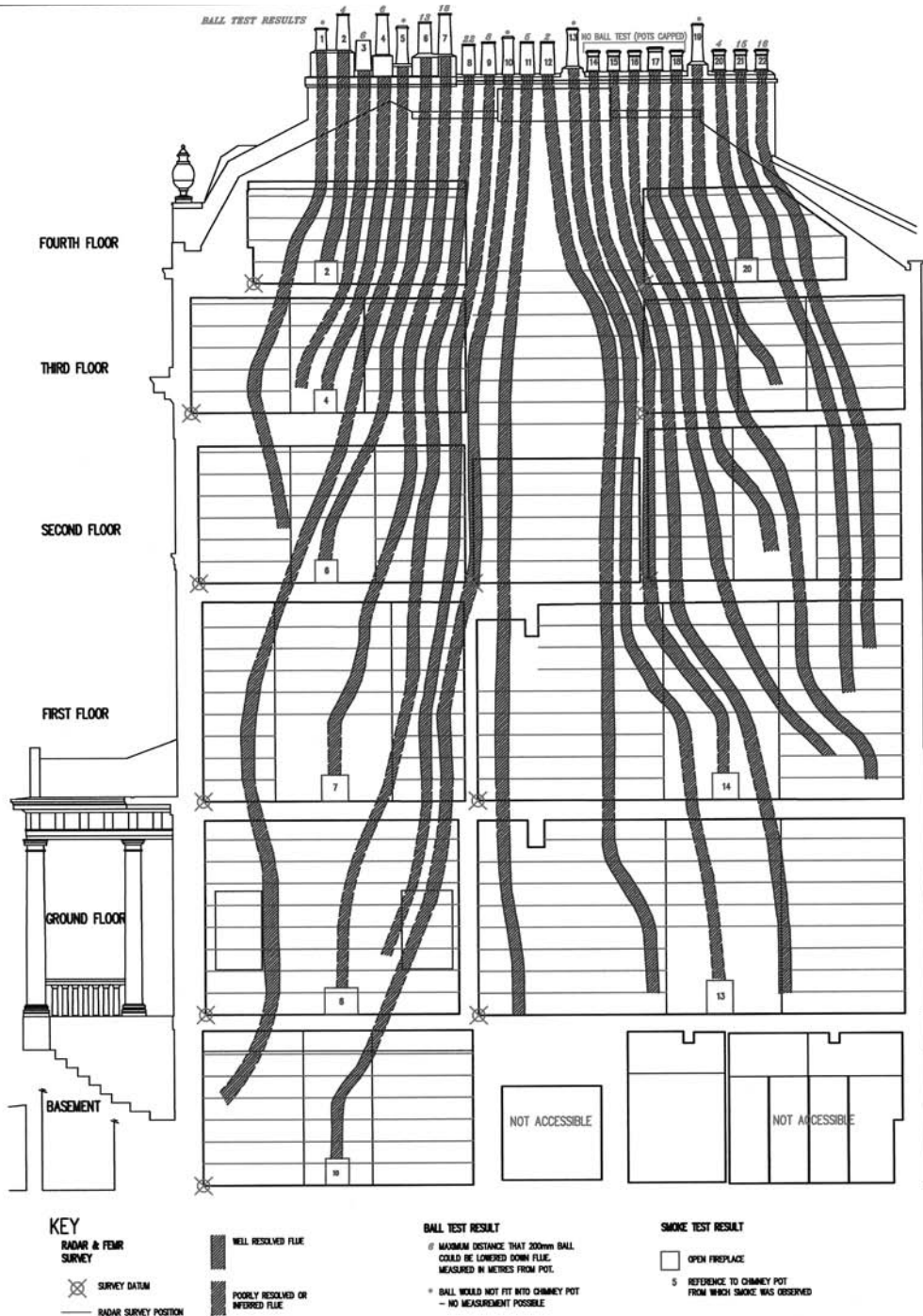

Illus 3.19.2 Results of an investigation to track flues in a party wall (reproduced from TAN 23).

The problems associated with the installation of metal chimneys in historic buildings are described in Standard 3.20. However, where such a chimney has to be installed, it will not normally create additional problems to maintain the minimum separation distances from combustible materials required by this standard.

**3.19.3 Issues to be considered**

Issue	Risks to historic/traditional buildings
1. Relationship of masonry chimneys to combustible materials	<ul style="list-style-type: none"> <li>• Built-in timber beams and joists may not comply with minimum separation distances from flues and remedial work can be destructive to historic fabric.</li> <li>• Mortar pointing to existing chimneys that are to be used for a combustion appliance may be in poor condition – remedial work will require the removal of wall finishes.</li> </ul>
2. Relationship of hearths to combustible materials	<ul style="list-style-type: none"> <li>• Maintaining the required air space below a hearth can require removal of either the hearth or the ceiling below to effect alterations to combustible ceiling support arrangements.</li> <li>• Timber beams or joists that penetrate the supporting hearth wall from the opposite side of the wall may present a risk of combustion. Remedial work can be destructive to historic fabric.</li> </ul>

**3.19.4 Recommendations to meet the standard**

The principal issue with respect to conversions is where an existing chimney is to be used to accommodate a flue for a combustion appliance. In such cases, the relationship of hearths and flues to combustible materials – usually timber beams, joists, dooks and ceiling support brackets – is a significant risk that must be properly assessed. An investigation to establish relationships between combustible materials and flues and hearths may involve the following tasks:

- some opening up of construction to establish the position of joist and beam ends (and other timber that may be built in) – carefully lifting floor boards adjacent to the chimney will usually suffice,
- inspecting the mortar joints in the masonry chimney to check their integrity and resistance to heat,
- inspecting the space below hearths supporting combustion appliances to check distances to combustible material,
- in the case of a listed building, listed building consent may be required before opening-up of historic fabric for inspection.

*Relationship of combustible material to existing flues and chimneys*

Where joists and beams are built into a chimney, and the thickness of the masonry wall is such that the distance from the end of the joist to the inside of the flue lining is less than 200mm, the end of the joist should be cut back to provide the appropriate gap. As a traditional stone-built chimney will generally have relatively slim construction surrounding the flue, it is likely that additional support, in the form of a metal bearer built into the wall, will be required to allow for a 200mm separation, as shown in Illus 3.19.3. There is a significant risk of combustion where the ends of beams and joists are built into slender masonry chimneys, as the gap between the end of the joist and the flue may be incompletely sealed. The temptation to avoid investigation and possible subsequent alteration to joist or beam support should be resisted.

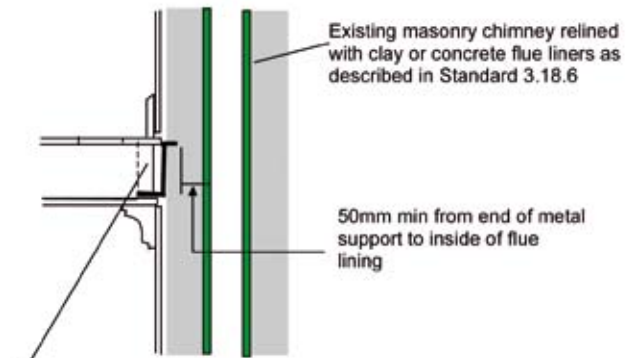

*Illus 3.19.3 Alterations to built-in floor joists to provide a minimum gap between the joist and flue where an existing masonry chimney is used for a combustion appliance.*

Floor joist cut back to at least 200mm from inside of flue liner supported on metal joist hanger with built-in tail 50mm min. from inside of flue liner. Ceiling reinstated at junction with chimney.

*Relationship of combustible material to hearths*

The space below a hearth should be investigated to determine the risk there to any combustible material. The most likely risk will be to timber supports to a lath and plaster ceiling. It is unlikely that the gap below the hearth can be increased, as this would mean either increasing the depth of the floor (or installing a suspended ceiling) or raising the height of the hearth. Either option will affect the historic character of the construction, thus it may be necessary to open up the space and replace the affected timber with metal support brackets where appropriate.

**3.19.5 Related standards**

Other related standards are:

- Standard 2.3 Structural protection
- Standard 3.18 Combustion appliances: protection from products of combustion
- Standard 3.20 Combustion appliances: removal of products of combustion

**3.20 Combustion appliances – removal of products of combustion****Standard 3.20**

Every *building* must be designed and *constructed* in such a way that the products of combustion are carried safely to the external air without harm to the health of any person through leakage, spillage, or exhaust nor permit the re-entry of dangerous gases from the combustion process of fuels into the *building*.

**3.20.1 Type of standard****Mandatory standard**

In the case of *conversions*, the *building as converted* must meet the requirement of this standard.

**3.20.2 Commentary**

The technical requirements for the construction and termination of flues from combustion appliances are very prescriptive in this mandatory standard and are well detailed within the guide to the standards, and also in the publications referred to within the guide. There can, however, be particular difficulties in complying with the requirements in historic building conversions. The notes below are intended to provide guidance on the range of options that are open to designers.

Two main categories of circumstance often arise:

1. Conversion to create a number of small units with independent heating systems and so a number of smaller boilers (eg a building converted into flats).
2. Conversion to provide a single user building with a central heating installation, usually incorporating a relatively large central boiler plant.

The options for flues are most flexible with natural gas or LPG fired boilers. Oil fired boilers have less flexibility, and the heavier the grade of oil used and the larger the boiler the less flexible the options become. Finally, solid fuel boilers have the most onerous restrictions on flue terminations and the least flexibility in terms of how the flues can be arranged.

The main issue with the creation of a number of small unit heating systems is finding a satisfactory way of terminating the flues from the individual boilers. It is most common now for domestic boilers to be wall mounted with fan assisted, balanced flues designed to be terminated at a wall. For conversions to create a number of separate

units, each with its own heating installation, the penetration of external walls to accommodate flues and flue terminals will usually be damaging to the character of historic walls.

The positioning of an outlet from a flue is strictly controlled, which may create difficulties in the following circumstances:

- a) Existing chimneys: Most traditional chimneys will comply with the minimum height requirements above the roofline, but where the height has to be increased the character of the roof may be compromised. This is more likely to be a problem with flammable traditional roof coverings, such as thatch and shingles.
- b) New chimneys: Unless very carefully located, the flue outlets can be very obtrusive and adversely affect the character of a historic roof.

New metal chimneys are required to be routed within the building to reduce the possibility of condensation in the chimney. Routing a chimney within a historic building can be difficult to achieve without considerable disruption to fabric and spaces. Alternatively, a metal chimney may be fixed externally if it is insulated and constructed of a material suitable for such use. However, such flues will inevitably be of quite large diameter and may be difficult to position on an external wall in a way that does not detract from the architectural and historic character of the building.

### 3.20.3 Issues to be considered

Issue	Risks to historic/traditional buildings
1. Installation of new flues	<ul style="list-style-type: none"> <li>• Both horizontal and vertical flues can be difficult to accommodate internally without disruption to historic spaces and fabric.</li> <li>• External chimneys and flues can be damaging to the character of historic buildings if poorly located.</li> </ul>
2. Location of flue terminals	<ul style="list-style-type: none"> <li>• Flue terminals to new chimneys are usually carried above roof level and can be visually intrusive within a historic roofscape.</li> <li>• Increasing the height of historic chimneys to meet the requirements of the standard may affect the architectural character of the building.</li> <li>• Multiple flue terminals (balanced flues), for example in a conversion to separate apartments, may be damaging to both the fabric and aesthetics of a historic wall.</li> </ul>

### 3.20.4 Recommendations to meet the standard

Natural gas or LPG fired boilers have the most flexible flue options. Many of these boilers now have the ability to run the flues for several metres horizontally, and so the boiler itself need not actually be located on an external wall. The location of the terminal must take into consideration the aesthetic impact on the building and the intervention with the fabric involved in forming the hole for the flue, as well as the normal technical requirements set out in the guide to the standards.

An alternative to the wall-mounted flue is a vertical flue arrangement. This can be individual flues for each boiler or, under certain circumstances, a combined flue arrangement for a number of boilers. Individual flues can be fan assisted, balanced flues working on a similar principle to the horizontal versions described above, but the range of boilers capable of utilising this system are more limited. They can also be conventional flues connected to open-flued boilers, but these are becoming less common in domestic sized boilers.

Combined flues can be designed for either conventional flues or fan-assisted balanced flue boilers. Proprietary systems now exist for this, and tend to handle up to ten or so boilers in each stack. Such systems have been in use on the Continent for a number of years but are new to the UK. Partly because they are new, these installations require special designs and, to be acceptable to verifiers, it is likely that detailed calculations would have to be submitted to demonstrate that the installations were satisfactory. Utilising these systems requires the boilers to be stacked, and this is often not possible in the irregular floor plans often required in historic building conversions. There are also several fire separation issues associated with vertical flues that pass through separating floors. The flues require to be housed within a fire-protected duct.

When dealing with a larger central boiler plant for a whole building, the options for boiler flues tend to be:

- a) Utilising an existing chimney by lining the flue and installing a conventional or fan-assisted conventionally



flued boiler. This is often a good solution in terms of minimising the visual impact on the building, but it does rely on finding and successfully lining an existing flue, which can be problematic if the flues are structurally unsound.

- b) Installing a fan-assisted flue terminal at the top of the flue, which is a variation on (a) above. Within limits, this can help overcome problems of the flue diameter being too small to permit a normal, conventionally flued boiler to operate correctly. The modern terminal fans can be quite neat, but they are usually clearly visible on the chimneystack and so the aesthetic impact of this would have to be assessed.
- c) Installing a commercially sized, fan-assisted balanced flue boiler. These are now available in much larger capacities than even five or six years ago, but require a suitable flue termination point on an outside wall within a few metres of the boiler location. They are also exclusively natural gas or LPG fired due to the restrictions on the height for terminals associated with large oil fired appliances. They are very useful where installing a vertical flue is not possible or would be highly disruptive.
- d) Utilising a flue dilution system is also possible for natural gas or LPG fired appliances only. In this system, the flues from conventionally flued boilers (natural draught or fan assisted) are connected into a duct and the combustion products are mixed with a large amount of fresh air, which is drawn through the duct by a fan to dilute the concentration of the combustion products to a level which can be discharged at a relatively low height. These installations require an intake and a louvered exhaust opening in a wall of the building. Silencers can be installed at the inlet and exhaust to reduce the noise from the fan, but, typically, these systems tend to create more noise than any of the other flue arrangements. Care must therefore be taken over planning restrictions and the like.

#### **3.20.5 Related standards**

Other related standards are:

- Standard 2.2 Separation
- Standard 2.9 Escape
- Standard 3.13 Heating
- Standard 3.19 Combustion appliances: relationship to combustion materials
- Standard 3.20 Combustion appliances: removal of products of combustion

## 4. SAFETY

### 4.1 Access to buildings

#### Standard 4.1

Every *building* must be designed and *constructed* in such a way that all occupants and visitors are provided with safe, convenient and unassisted means of access to the *building*.

Limitation:

There is no requirement to provide access for wheelchair users to:

- a) a *house*, where there are no *apartments* on the entrance *storey*;
- b) a *house*, where it is not *reasonably practicable* to construct a level or ramped access route between the point of access to, or from any car parking within, the *curtilage* of a *building* and an entrance to the *house*; or
- c) a *domestic building* not served by a lift, where there are no *dwellings* entered from a common area on the entrance *storey*.

#### 4.1.1 Type of standard

##### ***Reasonably practicable standard***

Every *conversion*, to which these regulations apply, must be improved to as close to the requirement of the standard as is *reasonably practicable*, and in no case be worse than before the *conversion*.

#### 4.1.2 Commentary

The implementation of this standard has the potential to make an adverse impact on the character of a historic building if changes to access are made without regard to the cultural significance of the building and its environment. In addition to the Building Standards, other legislation, which makes no allowance for the nature of historic buildings, should be taken into consideration. In particular, for conversions that will be used to provide a service, account should be taken of the Disability Discrimination Act 1995; the recommendations in the supporting Code of Practice, *Rights of Access, Goods, Facilities, Services and Premises* is particularly relevant to non-domestic buildings. This Guide, however, is intended to provide advice only on those elements specifically covered by the Technical Standards. The full range of provision required under the DDA can have far-reaching effects on historic buildings, and those with a duty within the DDA should be aware that their responsibility to cater for the needs of people with disability extends beyond matters addressed here.

Standard 4.1 is concerned with issues related to car parking, the approach to buildings, length of access routes, width of approach to houses and to buildings containing flats and maisonettes, and principal entrances, all of which have the potential to affect the historic environment. The provision of parking for houses is a matter for the planning authority.

From May 2007, draft amended standard 4.1 is:

Every *building* must be designed and *constructed* in such a way that all occupants and visitors are provided with safe, convenient and unassisted means of access to the *building*.

Limitation

There is no requirement to provide access for wheelchair users to:

- a) a *house*, between the point of access to, or from any car parking within, the *curtilage* of a *building* and an entrance to the *house*, where it is not reasonably practicable to do so; or
- b) a common entrance of a *domestic building*, not served by a lift, where there are no *dwelling*s entered from a common area on the entrance *storey*.

This standard will extend the requirements for access to more dwellings, but the guidance offered is still fully applicable.

**4.1.3 Issues to be considered**

Issue	Risks to historic/traditional buildings
1. Car parking	<ul style="list-style-type: none"> <li>• Parking within the curtilage of a historic building may be restricted by the nature of the historic environment, which may be damaged if parking recommendations are implemented fully.</li> <li>• Provision of parking (and associated construction works) may disturb hidden archaeology.</li> <li>• Historic surfaces may be unsuitable for car park purposes, or for travel over the surface by disabled people – replacement of such surfaces with modern materials may be unacceptable.</li> </ul>
2. Approach to buildings	<ul style="list-style-type: none"> <li>• The provision of a level or ramped access to the principal entrance can mean loss of historic features at the entrance, such as steps, railings and paving.</li> <li>• Existing surfaces to the access route may be of historic importance and their replacement with modern 'access-friendly' surfaces could result in loss of historic character.</li> <li>• Replacement of historic surfaces may disturb hidden archaeology.</li> </ul>
3. Length of access route	<ul style="list-style-type: none"> <li>• Reducing the length of an access route for disabled people by extending the road or car park may adversely affect the historic environment and any hidden archaeology.</li> </ul>
4. Width of approach to buildings	<ul style="list-style-type: none"> <li>• Creating an unobstructed width for an access route of 1.2m (or 1000mm for 1 or 2 dwellings) may not be practically possible without unacceptable alteration to historic surfaces or other features.</li> </ul>
5. Principal entrances, accessible entrances to houses	<ul style="list-style-type: none"> <li>• Altering the principal entrance of a building to comply with this standard is likely to have a significantly adverse effect on historic features and character.</li> </ul>

**4.1.4 Recommendations to meet the standard**

Historic buildings and their immediate environment do not lend themselves easily to alteration that will satisfy the functional requirements of this standard. However, the flexibility offered by the standard does mean that action may be taken in most situations to ameliorate the access difficulties of disabled people without damage to the historic environment or building. Every historic building is unique and, therefore, each building and its access must be subjected to an access audit, drawn up in conjunction with the conservation plan for the building, to ensure that the needs of both disabled persons and building are catered for as far as possible. As with other standards of this type, a 'do nothing' approach will not be acceptable. Additional guidance on accessing historic properties is contained in Young and Urquhart 1996 Technical Advice Note 7, *Access to the built heritage* and Jester et al, Preservation Brief 32: *Making historic properties accessible* and CADW Welsh Historic Monuments 2002, *Overcoming the Barriers: providing physical access to historic buildings*.

*(a) Parking*

The provision of parking within the curtilage of a historic building, with a proportion of spaces designated for use by disabled people, may or may not be possible. However, where space is available for parking, due regard must be paid to the design of the facility to reduce the possibility of accidental damage to the historic environment from careless parking of vehicles. The use of upstand kerbs and bollards that are sympathetic to the building may be required to prevent contact with historic fabric.

*(b) Approach to buildings*

In the approach to buildings, the nature of the surface of the access route should allow unassisted access for everyone. Surfaces are of considerable importance to people with mobility impairments, as are routes between car parks, or setting down points, and the principal entrance. The approach should be graded as appropriate with a stable, firm and slip resistant surface. Existing paths should be modified to provide a suitable surface wherever possible, without adversely affecting the historic character or destroying historic materials and features. The most easily negotiated, slip resistant surfaces are:

- tarmacadam,
- asphalt,
- concrete paving blocks or slabs,
- bricks,
- natural stone slabs with a droved or rough finish.

For many conversions, the use of these modern surface materials may be acceptable. However, selection of the surface should recognise the importance of the particular historic setting and the use of the above materials may have to be reconsidered, in favour of a surface more appropriate to the setting. Some traditional surface finishes found within the curtilage of a historic building may be unsuitable for disabled access. It is usually possible to replace part of such surfaces, when they form an access route, with a more appropriate firm surface that will allow ease in manoeuvring. Existing surfaces can often be made accessible by providing a new base and resetting the paving materials, or otherwise modifying the surface.



*Illus 4.1.1 Natural stone paving forming access for disabled people to Duff House (Photo: D Urquhart).*

Examples of traditional historic surfaces that may present barriers to wheelchair access include:

- loose gravel,
- rubble paving,
- hononising,
- setts (with or without recessed joints) unless they are modern smooth-finished setts with flush joints,
- cobbles.

Obstructions to access should be carefully assessed. Kerbs, steps and steep gradients (exceeding 1 in 12) are obvious hazards for people with ambulatory difficulties. The needs of people with visual impairments must also be considered, where features such as chain link fences and bollards, which can cause problems for this group, should be removed from the access route.

The introduction of drop kerbs can usually be accommodated without difficulty. However, many historic buildings have steps forming part of the approach to the principal entrance. Such features are often an essential part of the character of the building and their removal or alteration may be unacceptable. However, it may be possible with sympathetic design to retain the original historic feature while introducing an alternative ramped approach.

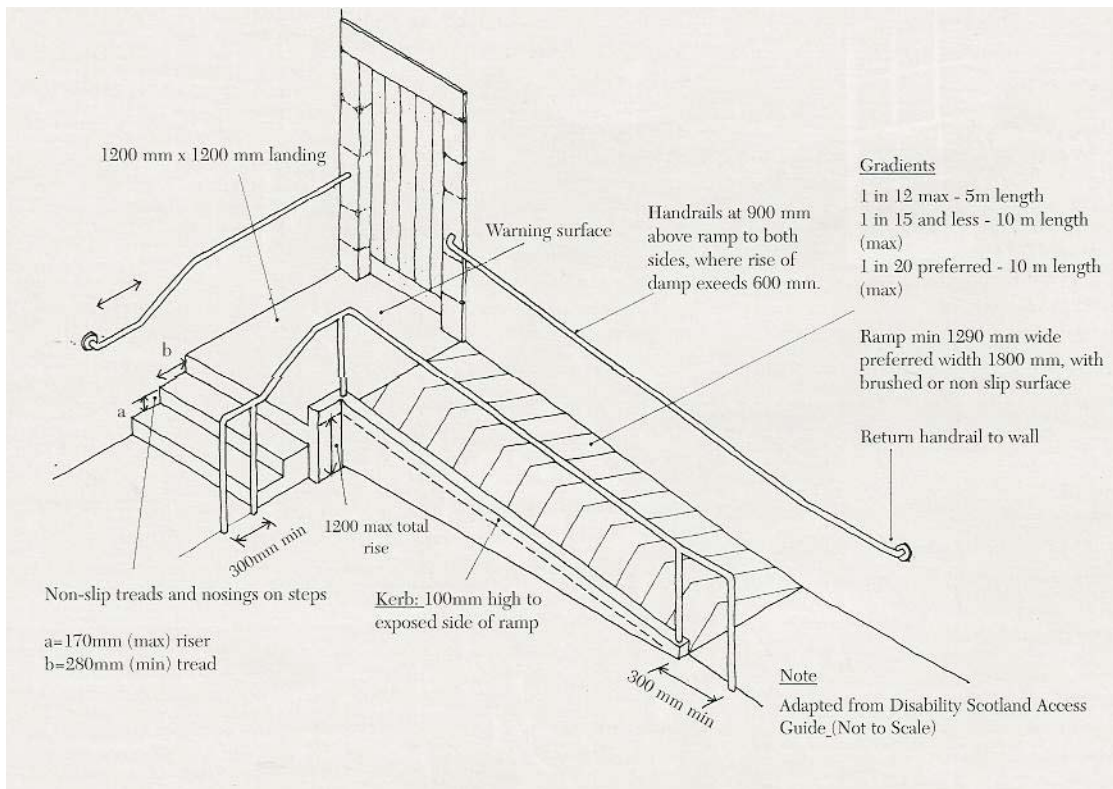

Illus 4.1.2 Design recommendations for ramped approach to a main entrance (from TAN 7 Fig 5).



*Illus 4.1.3 Sympathetically designed access ramp and steps to 1801 Category A listed converted bank building (Photo: D Urquhart).*

*(c) Platform lifts and ramps*

Many Georgian and Victorian properties, with direct access from street level, have a flight of steps spanning over an open basement well. Such an approach to a building will present a particularly difficult challenge to achieve a solution that provides access to wheelchair users and retains the historic character of the entrance. In such a case, the use of a platform lift constructed within the basement well may be an acceptable solution (Illus 4.1.4). Platform lifts tend to be visually intrusive but can be readily removed when necessary. Platform lifts can be used when it is not possible to construct an access ramp. For very sensitive situations, a more expensive solution is to provide a lift with retracting railing that lowers into the ground, minimising the visual impact. A significant drawback with an external platform lift is their exposure to the elements and the need for frequent maintenance.

Ramps are typically employed at principal entrances. In addition to the normal access design features (such as gradient, surface materials, kerbs and handrails), the location of the ramp, its materials and its detailing are critical for its compatibility with a historic building. For compatibility, the ramp should be arranged adjacent and parallel to the main façade where possible. The exposed sides should be constructed of the same material as the façade and have similar materials, colours, textures, proportions and scale to the main wall of the building.

*(d) Length and width of access route*

The 45m maximum travel distance from a road or parking space may not be achievable in some situations. Where this is the case it may be possible to construct a dropping-off point that is closer to the principal entrance. Where this cannot practically be achieved, and the length of access route exceeds 45m, either the width of access route should be increased or a passing area for wheelchairs or pushchairs be provided (which can also act as a rest area for people with disabilities).



*Illus 4.1.4 Access to platform lift installed at Bute House, Edinburgh. Note the reuse of iron railings to form the access gate to the lift. (Photo: NTS).*

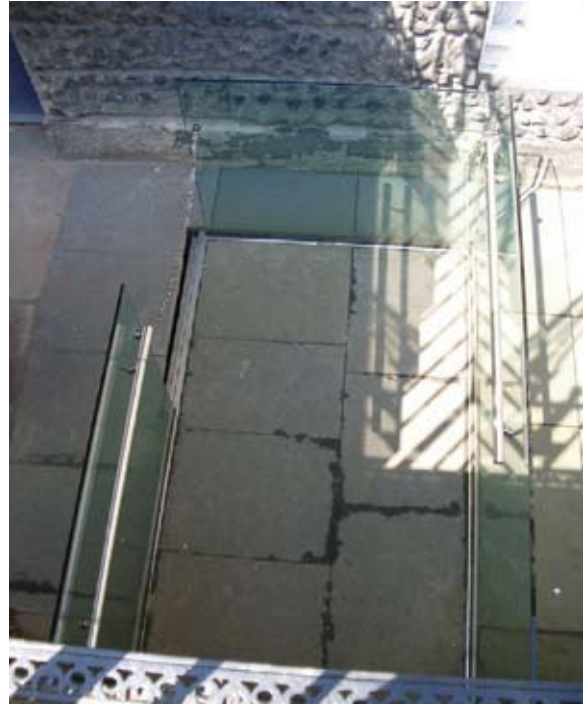

*(e) Principal entrances*

The principal entrance to a historic building is the feature that is likely to present the greatest difficulty to designers in achieving accessibility while conserving the cultural integrity of the entrance. The main difficulties that may have to be addressed are:

1. A raised threshold, either in the form of a step or deep threshold plate. Where the entrance steps are not historically significant, a step at the threshold may be overcome by the provision of a platt, laid to a slight gradient to provide a smooth entrance to the building (Illus 4.1.5(a)). Where the steps are of historic masonry, and there is no alternative to providing a smooth level entrance, the steps should be retained wherever possible and buried under the new accessible entrance (Illus 4.1.5(b)). Where a door threshold exceeds the recommended height, it can be altered or removed and replaced with one that meets the standard and is compatible with the historic entrance. However, if the threshold is historically significant it can be made accessible by adding a bevel to each side to eliminate the raised step.

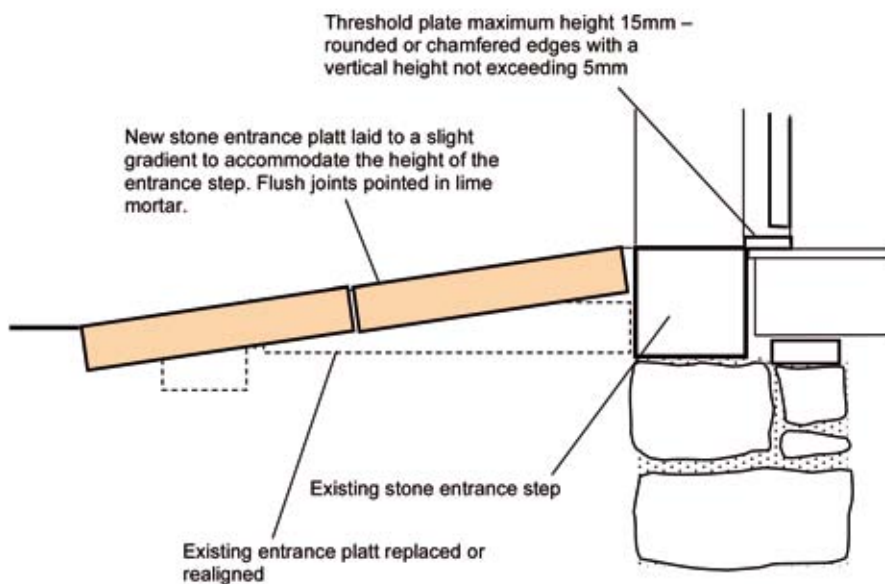

*Illus 4.1.5(a) Typical arrangement at a principal entrance to prevent a trip hazard.*

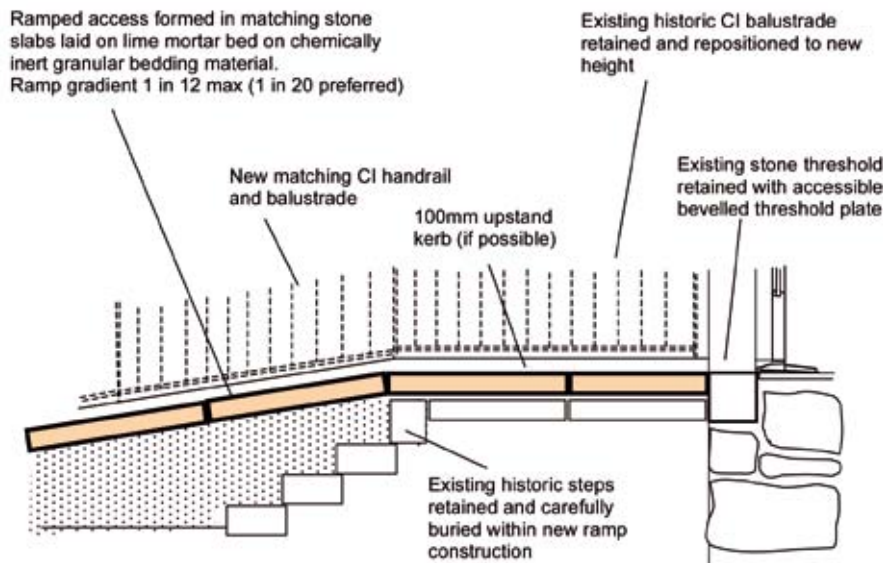

*Illus 4.1.5(b) New ramped entrance that preserves the existing historic entrance steps.*

2. The recommended door leaf width to provide a clear opening width of at least 800mm may not be achievable without major alterations to the historic door opening. In such a case, it may be possible to gain a few millimetres of width by reducing the depth of doorstops. As a general rule, historic doors should not be replaced and door openings and frames should not be altered.
3. Many historic doors contain a glazed panel that will meet the requirements of the standard. However, in the case of other panelled doors, each situation must be individually assessed and, where the character of the door is not compromised, it may be possible to insert a glazed panel or panels into the door. In other cases where the historic character of the door will be affected, the door should be fitted with an automatic opening mechanism, which can make single or double-leaf doors fully operational by disabled people.
4. In a situation where it is not practically possible to alter an existing entrance, there may be a case for forming a new entrance in an appropriate location, which does not affect the historic character. Alternatively, a window opening may be modified to form an accessible entrance. Such solutions should, however, be considered only as a last resort and after all other possibilities have been exhausted.

#### **4.1.5 Related standards**

Other related standards are:

- Standard 2.9 Escape
- Standard 3.6 Surface water drainage
- Standard 4.3 Stairs and ramps
- Standard 4.4 Pedestrian protective barriers
- Standard 4.8 Danger from accidents



## 4.2 Access within buildings

### Standard 4.2

Every *building* must be designed and *constructed* in such a way that:

- (a) in non-domestic *buildings*, safe, unassisted and convenient means of access is provided throughout the *building*;
- (b) in *domestic buildings*, safe and convenient means of access is provided to each *dwelling* and throughout the common areas;
- (c) in *residential buildings*, a proportion of the *rooms* intended to be used as bedrooms must be accessible to wheelchair users;
- (d) in *dwellings*, safe means of access is provided for occupants throughout the *dwelling*; and
- (e) in *dwellings*, safe and unassisted means of access is provided for visitors throughout at least one *storey* and to *sanitary facilities*.

#### Limitation

There is no requirement to provide access suitable for wheelchair users:

- (a) in a non-domestic *building* not served by a lift, to a *room*, intended to be used as a bedroom, that is not on an entrance *storey*; or
- (b) in a *domestic building* not served by a lift, to common areas, other than on an entrance *storey*.

### 4.2.1 Type of standard

#### **Reasonably practicable standard**

Every *conversion*, to which these regulations apply, must be improved to as close to the requirement of the standard as is *reasonably practicable*, and in no case be worse than before the *conversion*.

### 4.2.2 Commentary

The application of this standard to the conversion of historic buildings has the potential to cause significant disruption to the historic character and fabric of a building. While this standard is one that is classified as a '*reasonably practicable*' standard, there is a danger that, in trying to satisfy the requirements of the standard and other related legislation, such as the provisions and supporting Code of Practice of the Disability Discrimination Act 1995, access provision takes precedence over preservation of historic character. Historic buildings and landscapes were not designed to be readily accessible to disabled people and thus introduce complex contradictions when attempting to adapt such buildings to modern accessibility needs while preserving their historic character.

However, with careful analysis of the building and sympathetic design it should be possible, in most conversions, to make the building (or parts of the building) accessible to people with disabilities. It is obvious that most difficulties will be caused by the need to make the building accessible to wheelchair users, such as in the provision of:

- a) Corridors of sufficient unobstructed width (the standard is 1.2m for common access to dwellings within buildings and for non-domestic buildings).
- b) Internal doors of sufficient clear opening width (750mm minimum width) may be impracticable. Even when this minimum width is available, there is the potential for damage to historic fabric as wheelchairs are manoeuvred through narrow openings.
- c) Unassisted access at changes in level. Many historic buildings have been extended over the years with floors between various parts having differences in level. Accommodating wheelchair access between changes in level may be difficult or even impossible.

- d) Access for wheelchair users in public areas such as in self-service restaurants.
- e) Access to storeys above and below the main entrance level, usually through the provision of a lift. The accommodation of a passenger lift within many historic building conversions may be problematic, possibly causing serious disruption to character and fabric.

Experience suggests that most buildings can be successfully and effectively altered as part of the conversion process, but this does require a good knowledge and understanding of both historic building conservation and the needs of people with disability. For the successful implementation of this standard it is recommended that an *access audit* is undertaken, which considers both the features of the building and the wide range of disabilities likely to be encountered.

Every effort should be made to preserve the features that make the building historically important. These features include:

- materials,
- form and style of the property,
- principal elevations,
- major architectural features and
- significant spaces both inside and outside the building.

From May 2007, draft amended standard 4.2 is:

*Every building must be designed and constructed in such a way that:*

- a) *in non-domestic buildings, safe, unassisted and convenient means of access is provided throughout the building;*
- b) *in residential buildings, a proportion of the rooms intended to be used as bedrooms must be accessible to a wheelchair user;*
- c) *in domestic buildings, safe and convenient means of access is provided within common areas and to each dwelling;*
- d) *in dwellings, safe and convenient means of access is provided throughout the dwelling; and*
- e) *in dwellings, unassisted means of access is provided to, and throughout, at least one level.*

*Limitation*

*There is no requirement to provide access for wheelchair users:*

- a) *in a non-domestic building not served by a lift, to a room, intended to be used as a bedroom, that is not on an entrance storey; or*
- b) *in a domestic building not served by a lift, within common areas and to each dwelling, other than on an entrance storey.*

This standard will extend the requirements for access within dwellings, though it makes more allowance in dwellings for changes in level within a storey. Otherwise, the guidance offered is still applicable.

### 4.2.3 Issues to be considered

Issue	Risks to historic/traditional buildings
1. Access between storeys	<ul style="list-style-type: none"> <li>• The unsympathetic installation of lifts and accessible stairs can be destructive to historic fabric and visually intrusive within important spaces.</li> <li>• Accommodation of lift cars and lift motors etc. may require structural strengthening of the building, with associated damage to historic fabric.</li> </ul>
2. Common access to dwellings within buildings containing flats and maisonettes	<ul style="list-style-type: none"> <li>• While a building of up to four storeys may be constructed without a lift, stairs in common access areas should be accessible to ambulant disabled people (designed to standard 4.3 – refer to guidance in Part II, 4.3 of this book). Alteration of existing stairs to comply with this standard may result in unacceptable damage to historic fabric and spaces.</li> <li>• Where lifts are installed – see note 1 above.</li> </ul>
3. Internal doors	<ul style="list-style-type: none"> <li>• The standard states that the minimum clear opening widths of doors are required to be between 750mm and 800mm, depending on the situation. Increasing the opening width of a historic door may require extensive alterations to the supporting structure, doorframe and door leaf.</li> <li>• In non-domestic buildings, the provision of a 300mm unobstructed space on the side next to the leading edge of an internal door accessible to disabled people may not be possible without major alterations to spaces.</li> <li>• The requirement for a door across a corridor or passageway to have a clear glazed vision panel may have a deleterious effect on the historic character of the door.</li> </ul>
4. Accessible storeys and lobbies	<ul style="list-style-type: none"> <li>• In domestic buildings, the provision of an accessible storey to allow access to all apartments may result in the loss or damage of historic features. In particular, the provision of level or ramped access throughout the storey needs to be treated carefully. Minimum corridor and internal door widths may not be achievable without significant damage to historic finishes.</li> </ul>

### 4.2.4 Recommendations to meet the standard

In addressing this standard, and also Standard 4.1, the first step must be to conduct an access audit of the existing building, to identify barriers to accessibility and the potential impact on historic fabric and character of any improvements to access that may be required. It is outside the scope of this guide to identify all the features of an access audit, as this will cover issues that are unlikely to impinge directly on the requirements of the standard. For further information, reference should be made to the Code of Practice of the Disability Discrimination Act 1995 and to the Code of Practice BS 8300: 2001, *Design of buildings and their approaches to meet the needs of disabled people*. For larger and more complex buildings an access audit should be conducted by a person experienced in this work. Persons with disabilities can be particularly helpful in assessing specific barriers.

The extent to which a historic interior can be modified depends on the cultural significance of the building and features such as its materials, doors, finishes (panelling, decorative plaster work and the like), and the importance of spaces and their arrangement. The principal rooms and spaces (such as entrance halls) are likely to be difficult to alter without affecting their character. Less significant rooms and spaces may generally be changed without adversely influencing the building's historic character.

#### *Providing access to and between storeys*

It is the installation of accessible stairs, ramps and passenger lifts that creates the greatest challenge to designers.

Stairs in common areas should be designed to be accessible by ambulant disabled people. Stairs often present insurmountable barriers to many people with disabilities and it may be difficult to modify the physical characteristics of existing historic stairs. However, some relatively simple improvements can be made that will improve their accessibility, such as:

- adding a handrail if none exists – ends of rails should return to the wall to avoid catching on clothing or bags,
- filling-in open risers,
- fitting colour contrasting, non-slip strips for people with visual impairments.

To accommodate differences in level within a storey, a moveable ramp is sometimes employed. This is unlikely to be an acceptable long-term solution for historic buildings and a 'permanent' ramped access will be required. However, the design of the ramp should respect the principle of reversibility and avoid the destruction of important historic features. Historically important steps should be retained where possible and hidden within the design of the ramp.

As an alternative to a ramp, a wheelchair platform stairlift or a powered lifting platform may be appropriate for some situations where a stair cannot be altered. Provided space is available, such installations can often be accommodated without disruption to historic features. Inclined stairlifts, which carry a wheelchair on a platform up a flight of stairs, tend to be visually intrusive. They are, however, a reversible installation.

The recommended clear opening width for internal doors, which may be between 750mm and 800mm depending on the situation, may not be achievable without major alterations to the historic door opening. In such a case, it may be possible to gain a few millimetres of width by reducing the depth of doorstops. As a general rule, historic doors should not be replaced and door openings and frames should not be altered.

Many historic doors contain a glazed panel that will meet the requirements of the standard. However, in the case of other panelled doors accessible to disabled people in non-domestic buildings, each situation must be individually assessed and, where the character of the door is not compromised, it may be possible to insert a glazed panel or panels into the door. Where it is not possible to provide an unobstructed space of at least 300mm next to the leading edge of the door, the door should be fitted with an automatic opening mechanism, which can make single or double-leaf doors fully operational by disabled people.

There will be many conversions of both domestic and non-domestic buildings where access to storeys will require the installation of a passenger lift. The viability of the conversion will frequently depend on such a provision. The positioning of the lift is one of the key decisions that will have to be addressed at the earliest stage in the design process if an accessible building is to be achieved with the minimum disturbance of historic fabric. Clearly there can be no standard solution to this problem and each situation must be assessed on its individual circumstances. Ideally a lift installation should be located within a secondary space, such as a store or office, and not in a primary space.

The most recently developed lifts use lightweight, flexible, polyurethane-covered steel belts to replace conventional steel ropes. These weigh up to 20% less than conventional ropes and are more flexible. This means that the system eliminates the need for a separate, costly machine room because the mechanism can fit on top of the shaft and may offer significant advantages where weight and space saving are necessary in a historic building conversion. All the bearing loads can be transferred to the pit, thus reducing loads at roof level and reducing structural costs. Where it is not possible to install a lift within the existing envelope without serious disruption to historic spaces and fabric, it may be appropriate to accommodate a passenger lift within a sympathetically designed extension to the building.

Some buildings may have existing historic passenger lifts that do not comply with the standard required because of their size (too small for a wheelchair), operational features or detailing. These lifts are part of the history of the building and should be retained whenever possible, provided their use does not compromise safety. It is usually possible to upgrade them to improve their accessibility; for example, control panels can be made more accessible and modern signalling systems installed.

#### **4.2.5 Related standards**

Other related standards are:

- Standard 2.9 Escape
- Standard 4.1 Access to buildings
- Standard 4.3 Stairs and ramps
- Standard 4.4 Pedestrian protective barriers
- Standard 4.8 Danger from accidents

### 4.3 Stairs and ramps

#### Standard 4.3

Every *building* must be designed and *constructed* in such a way that every level can be reached safely by stairs or ramps.

#### 4.3.1 Type of standard

##### *Reasonably practicable standard*

Every *conversion*, to which these regulations apply, must be improved to as close to the requirement of the standard as is *reasonably practicable*, and in no case be worse than before the *conversion*.

#### 4.3.2 Commentary

This regulation covers the provision of stairs and ramps to give safe access between different levels within and adjacent to a building. It covers the geometry of stairs and ramps, giving maximum and minimum dimensions for flights, treads, risers, landings, pitch line, handrails and headroom. In the conversion of a historic building, it is possible to satisfy the requirements of Standard 2.9 'Escape' by building a completely new stair or ramp within a new enclosure (for instance as an extension to the existing historic fabric), this new stair or ramp will be expected to fulfil all the requirements of the standard. Where it is necessary to insert the new stair or ramp into the fabric of the historic building, it will have to fulfil as many of the numerous requirements of this regulation as is '*reasonably practical*'.

Where an existing stair or ramp is being retained in the conversion it should be improved as much as possible to satisfy as many of the numerous requirements of this regulation as practicable, taking into account the limitations imposed by its historic shape and geometry. However, it is likely that many important historic stairs, which it is necessary to retain in any conversion, will not meet all the requirements of this regulation. It is important, therefore, to assess carefully all the various features of a historic stair to ensure that, in introducing alterations, the important character of the stair is retained.

#### 4.3.3 Issues to be considered

Issue	Risks to historic/traditional buildings
1. Width of stair flights	<ul style="list-style-type: none"> <li>The space available for a new stair or the width of a retained existing stair may not comply with the widths prescribed in this regulation.</li> </ul>
2. Rise, going, tread & pitch of stairs	<ul style="list-style-type: none"> <li>The space available for a new stair and the existing retained floor levels may mean that the rise, going, tread or pitch dimension cannot be made to match those given in this regulation. Similarly, where an existing stair is retained in a conversion, its rise, going, tread or pitch are quite likely to vary from the criteria recommended in this regulation.</li> </ul>
3. Number of rises in a flight	<ul style="list-style-type: none"> <li>It is common to find open risers in industrial and in some humble commercial and residential historic buildings. These are not recommended in the regulations but it is often damaging to the historic fabric and aesthetically unacceptable to close them in.</li> <li>The requirement to have contrasting nosings to assist those with visual impairment can be damaging to the historic fabric and be aesthetically unacceptable in most important historic buildings.</li> </ul>
4. Stair Landings	<ul style="list-style-type: none"> <li>The requirement to provide a landing at the top and bottom of every flight should not cause difficulty in most conversions of historic buildings, as most original and historic stairs were so provided.</li> <li>Providing a landing to comply with the requirements of Standard 4.3.7 may, however, be impossible given the existing dimensions of the stair or space available within the historic fabric for a new stair.</li> </ul>

5. Width of stair landings	<ul style="list-style-type: none"> <li>The requirement to provide a landing equal to the width of the stair should not cause difficulty in most conversions of historic buildings, as the landings to most original and historic stairs do match the width of the stair.</li> </ul>
6. Lengths of stair landings	<ul style="list-style-type: none"> <li>In some cases, it may not be possible to achieve a landing length of 1200mm due to the geometry of the existing stair or the space available within the historic fabric for a new stair.</li> </ul>
7. Tapered Treads	<ul style="list-style-type: none"> <li>Many historic buildings are served by existing taper-tread stairs, many of which will be built of stone or brick and will not comply with the geometric requirements of this regulation.</li> </ul>
8. Pedestrian Ramps	<ul style="list-style-type: none"> <li>Many historic buildings incorporate ramps to connect one part on one level with another part at another level. Often these will be 'short and steep' and will not comply with this regulation.</li> <li>Existing ramps within historic buildings may be less than the recommended effective width of 1m and it is likely that it will be impossible to increase this width without severe damage to the historic fabric.</li> </ul>
9. Ramp landings	<ul style="list-style-type: none"> <li>The requirement to have a landing at the top and bottom of every ramp flight should not cause difficulty in most conversions of historic buildings as most original and historic ramps were so provided.</li> </ul>
10. Width of ramp flights	<ul style="list-style-type: none"> <li>The requirement to provide a landing at least the width of the flight should not cause difficulty in most conversions of historic buildings, as the existing landings are likely to be of this width.</li> </ul>
11. Length of ramp landings	<ul style="list-style-type: none"> <li>The requirement to provide landings of a minimum length of 1.2m or 1.0m, where serving only 1 or 2 dwellings, may be impossible given the existing dimensions of the ramp or space available within the historic fabric for a new stair.</li> </ul>
12. Handrails to stairs & ramps	<ul style="list-style-type: none"> <li>Where a new stair is being constructed either in an extension to the historic building or within a new stairwell within the historic building, it is likely that a handrail or handrails can be provided to satisfy the requirements of this regulation.</li> <li>Where, however, an existing stair is to be incorporated into the conversion it is quite possible that the height and geometry of the existing handrails will not match the requirements of this regulation.</li> </ul>
13. Headroom on stairs and ramps	<ul style="list-style-type: none"> <li>Fitting a new stair into a historic building can be geometrically extremely challenging to the designer, especially where it is needed to serve many different floor levels and when the distance between floors is not regular. Where the stair serves a top attic floor within existing roof pitches it is possible that the requirements of this regulation will be breached over part of the width of the stair.</li> </ul>

#### 4.3.4 Recommendations to meet the standard

As stated above, new stairs or ramps constructed in new-build extensions to historic buildings should comply with all the requirements of this regulation.

Where an existing stair is being retained within a historic building conversion each individual regulation must be studied and, where possible, the existing stair should be improved to come as close to the regulation as reasonably practicable. The following points should be noted:

- a) It is usually impossible to change the major geometry of the stair or ramp and things like the width, rise, going, tread, pitch, number of rises in a flight, and the location, width and length of landings will all have to remain as existing.
- b) It may be possible to re-hang doors so they do not swing out across the stair, ramp or landings.
- c) It may be possible to form lobbies to contain doors so that they do not swing out across the stair, ramp or landings, as illustrated in the diagrams in Standard 4.3.1.
- d) For less historically important stairs, where some change is aesthetically and historically acceptable, subtle changes to the pitch and rise can be made by adding material to each tread, but this needs great care not to compromise any adjacent stringer, balustrade or panelling design.
- e) For less historically important stairs, open risers can be closed by the simple addition of a new riser board or

boxed in by plating the underside of the whole flight.

- f) The requirement to have contrasting nosings can be effected by:
- paint,
  - tape (not recommended as it has a very short wear-life and looks very untidy when worn),
  - a proprietary metal nosing, or
  - for particularly sensitive locations a carpet with a woven-in strip can be used.
- g) It is rarely possible to increase the width or length of a landing but it is sometimes possible to remove obstructions that encroach onto the arc of the 'effective width of landing'
- h) Stairs incorporating tapered treads are usually narrow and may not comply with the requirements for width or minimum tread width at the narrow end. Where a taper tread stair is actually **wider** than required under Standard 4.3.2, and where acceptable historically and aesthetically, a handrail can be added at the narrow end to stop people using the innermost part of the tread and thus complying with the requirement for a minimum tread width at the narrow end.
- i) It may be preferable to substitute single steps for short steep ramps or in other situations to substitute sharp shallow ramps for very low steps which are deemed a trip-hazard.
- j) It may be possible to raise the height of existing balusters or handrails to comply with attractive and sympathetic additions.

Where a new stair is being inserted into a historic building it should comply as closely as possible with the requirements of this regulation. Some leeway may be acceptable for one or more of the following aspects provided some others comply:

- width,
- rise,
- going,
- tread,
- pitch,
- number of rises,
- location, width and length of landings and
- heights and positions of handrails.

#### **4.3.5 Related standards**

Other related standards are:

- Standard 2.9 Escape
- Standard 4.1 Access to buildings
- Standard 4.2 Access within buildings
- Standard 4.4 Pedestrian protective barriers
- Standard 4.8 Danger from accidents

## 4.4 Pedestrian protective barriers

### Standard 4.4

Every *building* must be designed and *constructed* in such a way that every sudden change of level that is accessible in, or around, the *building* is guarded by the provision of pedestrian protective barriers.

#### Limitation

This standard does not apply where the provision of pedestrian protective barriers would obstruct the use of areas so guarded.

### 4.4.1 Type of standard

#### Reasonably practicable standard

Every *conversion*, to which these regulations apply, must be improved to as close to the requirement of the standard as is *reasonably practicable*, and in no case be worse than before the *conversion*.

### 4.4.2 Commentary

This regulation covers the provision of walls or balustrades ('barriers') at the edges of sudden changes of level between adjacent floor levels, specifying when they are required, their height and the resistance to penetration by children.

Many historic buildings incorporate partially guarded changes of level, which are the very essence of the building, its history and importance. Also, many historic buildings are actually groups of separate buildings of the past brought together over decades or centuries to form the 'building' we know today. In many cases, the separate buildings were on different levels and joining them together has resulted in sudden changes in level at the interface. In domestic and commercial buildings balustrades of some sort or other guarded most of such sudden changes of levels because the owners wanted safe buildings for their family or staff.

### 4.4.3 Issues to be considered

Issue	Risks to historic/traditional buildings
1. Partially unguarded changes of level in existing buildings.	<ul style="list-style-type: none"> <li>The improvement of the existing balustrade or barrier to comply fully with this standard may be unacceptable spatially, historically or aesthetically.</li> <li>Many historic buildings incorporate partially guarded changes of level which are the very essence of the building, its history and importance. Many historic buildings are actually groups of separate buildings of the past brought together over decades or centuries to form the 'building' we know today. In many cases the separate buildings were on different levels and joining them together has resulted in sudden changes in level at the interface.</li> </ul>
2. Unguarded changes of level in existing buildings	<ul style="list-style-type: none"> <li>Historic industrial buildings often incorporate sudden totally unguarded changes of level due to the industrial process they were designed for, or the requirement for the easy movement of goods. These tend to be less sensitive historic environments and suitable barriers can usually be incorporated to comply with this standard.</li> </ul>
3. Introduction of ramps to provide accessible routes about the building to satisfy Standard 4.1	<ul style="list-style-type: none"> <li>The introduction of ramps within a historic building often means that there is a change in level between the edge of the ramp and the surrounding floor or ground and, where this exceeds 600mm, a balustrade or barrier is required. Visually this may be unacceptably intrusive within an important historic building.</li> </ul>

### 4.4.4 Recommendations to meet the standard

Whether an existing balustrade or barrier can be improved to comply fully with this standard will depend on the status and importance of the historic building and its sensitivity to change.



- a) Existing balustrades can be made safer, particularly for young children, by inserting additional balusters between existing widely spaced balusters. Usually it is better to insert strong, thin, plain and simple, obviously modern bars rather than to try to replicate the historic fabric. When painted a dark colour the new bars can almost merge inconspicuously with the other components of the balustrade. Safety may also be improved by inserting thin tensioned wires into the balustrade, although the balustrades may require alteration.
- b) Existing non-compliant balustrades can be made safe by the application of steel or non-ferrous mesh to one side but this has to be carefully chosen to accurately fit the opening or to fit between framing members.
- c) Existing balustrades can be raised in height by the addition of secondary raised handrails of a similar design to the original or of an overtly modern design that does not pretend to be part of the original.
- d) New balustrades at the edges of very slight changes in level and where the 100mm sphere rule does not apply can be both functional and decorative and contribute to the space.
- e) Balustrades with horizontal members are tempting and easy for young children to climb. Such balustrades in historic buildings, used as schools, can be made safer by the addition of fine grid metal mesh or glass sheeting (laminated or toughened) applied to the stair side.
- f) At the edges of ramps for wheelchair users, and where it is spatially, historically or aesthetically unacceptable to provide a full height barrier or balustrade to comply with this standard, it may be reasonable to provide a sufficiently high upstand to the edge of the raised area that will stop a wheelchair running off the edge.
- g) The need for full height barriers or balustrades to the edges of new external ramps can often be avoided by adjusting the surrounding groundscape to reduce the difference in height to less than 600mm. The edges of such ramps should still be provided with a raised kerb sufficient to prevent a wheelchair running off that edge.

#### **4.4.5 Related standards**

Other related standards are:

- Standard 2.9 Escape
- Standard 4.1 Access to buildings
- Standard 4.2 Access within buildings
- Standard 4.3 Stairs and ramps
- Standard 4.8 Danger from accidents

## 4.8 Danger from accidents

### Standard 4.8

Every *building* must be designed and *constructed* in such a way that:

- (a) people in and around the *building* are protected from injury that could result from fixed *glazing*, projections or moving elements on the *building*;
- (b) fixed *glazing* in the *building* is not vulnerable to breakage where there is the possibility of impact by people in, and around, the *building*;
- (c) both faces of a window and rooflight in a *building* are capable of being cleaned such that there will not be a threat to the cleaner from a fall resulting in severe injury;
- (d) a safe and secure means of access is provided to a roof; and
- (e) manual controls for windows and rooflights can be operated safely.

Limitation

Standards 4.8(d) & 4.8(e) do not apply to *domestic buildings*

### 4.8.1 Type of standard

#### **Reasonably practicable standard**

Every *conversion*, to which these regulations apply, must be improved to as close to the requirement of the standard as is *reasonably practicable*, and in no case be worse than before the *conversion*.

### 4.8.2 Commentary

The guidance is intended to prevent the creation of dangerous obstructions, to allow safe cleaning of windows and to provide safe access to roofs. It is therefore specifically intended for the design of new buildings. The conversion of historic buildings, where existing features may present an inherent risk of accidents, will set challenges to the designer that will not occur in new build. While the requirement is to make improvements to as close as reasonably practicable to the standard, a safe environment must be achieved without adversely affecting the historic character of the building. Glazed features on roofs, typically cupolas and rooflights, may require special measures such as access ladders, walkways and protective barriers to be incorporated to provide safe access for cleaning and maintenance. These features can be disruptive to the historic roof and, where permanent access is not required, alternative access options may be considered, for example the use of a hydraulic platform.

From May 2007, a draft amended standard 4.8 is being considered:

An amendment to require manual controls for all ventilation, not just windows and rooflights, is being considered. It may also apply to domestic as well as non-domestic buildings. The guidance offered remains applicable.

### 4.8.3 Issues to be considered

Issue	Risks to historic/traditional buildings
1. Collision with projections	<ul style="list-style-type: none"> <li>• Many historic buildings have important projecting features where their alteration or removal would damage the historic character of the building. Examples include: <ul style="list-style-type: none"> <li>- low door lintels,</li> <li>- a balcony projecting over a path,</li> <li>- a stone oriel window where the base of the projecting stonework intrudes into the circulation space.</li> </ul> </li> <li>• The standard states that a door that swings both ways across a route of passage should be glazed or have a vision panel. The alteration of a historic door in this way may be unacceptable.</li> </ul>
2. Collision with glazing	<ul style="list-style-type: none"> <li>• Glazing in doors or in glass screens should be designed to resist impact. However, the replacement of historic glass (such as crown or plate glass) with modern impact resistant glass will result in a loss of authenticity.</li> </ul>
3. Cleaning of windows and rooflights	<ul style="list-style-type: none"> <li>• A window or rooflight that is more than 4m above the adjacent ground or internal floor level, and which is to be cleaned from inside the building, may require anchor points for safety harness. Fixing of anchor bolts may cause damage to sensitive surfaces.</li> <li>• Fitting external window access systems to walls and roofs may be unacceptable.</li> </ul>
4. Guarding of windows for cleaning	<ul style="list-style-type: none"> <li>• For windows on the second floor and above, where cleaning is from the inside, require permanent guarding to be fixed 1.1m above floor level. This will be invasive within a historic space and may be unacceptable on an external façade.</li> </ul>

### 4.8.4 Recommendations to meet the standard

#### 1. Collision with projections

Obstructions may be indicated by way of warning signs or markings, additional lighting and mirrors.

The technical standard refers to a door that swings both ways across a route of passage and the requirement is that the door should be glazed or have a vision panel. Difficulties may arise in converting an existing building. The existing door may be of particular significance and altering it may be unacceptable in relation to the appearance of the existing building. A 'peep' hole may be less damaging than a vision panel to comply with clauses 4.1.5 (non-domestic building) or 4.1.8 (domestic building – common entrance to flats or maisonettes).

#### 2. Collision with glazing

Where collision with historic glazing is a risk and the glass has to be retained, it may be possible to reduce the risk of collision by applying:

- a clear polycarbonate screen in front of the glass, which can be removed at a later date if appropriate – the disadvantage is its flammability;
- a removable wire guard;
- a clear safety film to the glass to prevent shattering in the event of a collision;
- hazard warnings attached to the glass.

#### 3. Cleaning of windows and rooflights

The method of cleaning traditional sash and case windows, using simplex fittings is illustrated in Historic Scotland's Guide for Practitioners 3 *Conservation of Timber Sash and Case Windows* (2002). Diagrams show how a sash and case window may be safely cleaned from the inside, following guidelines in BS 8213. The guide also illustrates a system that allows an upper sash to open inwards for cleaning.

Compliance with the Technical Standards may be difficult and alternative methods of cleaning may have to be considered in conversion. Risk assessments and method statements may be required to demonstrate that cleaning operations can be carried out safely for cleaning windows that are difficult to access.

Anchor points for safety harnesses and lanyards may be used. The anchor points must be professionally installed, and

routinely examined and tested. Careful consideration should be given to the mounting positions of anchor points. Anchor eye bolts should not be fixed to the external façades of listed buildings. Internal mounting is preferable to external mounting on a window inband rybat. Within historic interiors, bolting the eyebolt into a floor joist is less obtrusive and less damaging to interior finishes than, for example, forming a recess in lath and plaster so that the eyebolt can be secured to the inside face of the stone wall. One specialist supplier and installer of safety systems includes a demountable door jam kit for installation between door stiles, which allows window access. This is used in conjunction with a harness, front and rear anchorage D-rings, a lifeline and rope grab.

Every effort should be made to clean windows safely from indoors and, if this is not possible, the use of extension pole systems and of mobile elevating work platforms should be explored. If, due to the design of the existing windows or their positions on roofs, these alternatives to cleaning from indoors are not possible, leaving certain windows uncleaned may be the only option.

#### *4. Guarding of windows for cleaning*

In BS 8213: 1991 it is noted that windows in historic buildings may be exempt from some of the recommendations contained within the BS. Guarding of windows as required by the Building Standards will, where this standard applies, entail the introduction of some form of guard to the window. This can be very damaging to the historic character of existing windows and may be an unacceptable addition to a window opening.

No system of guarding is available that will not disturb the original appearance of the window. However, the use of externally-fixed grilles or guard rails may be appropriate in cases where, after careful assessment of the impact on the historic character of the window and its opening, it is considered appropriate to provide a window guard (see Illus 3.16.1). This option tends to be less intrusive than options such as laminated glass, acrylic or polycarbonate sheets, which tend to be reflective. The guards should be set into the window opening and not flush-mounted on the outer surface of the wall. They can also be colour matched to the window or walling, as appropriate; for example, a dark colour tends to get 'lost' against the black appearance of window glass. Guard grilles (screens) and rails should be so designed that the structure of the window behind can be clearly 'read', that is, they unobtrusively merge into the overall façade of the building. Where a mesh guard is used, the pattern of the mesh should be square rather than diagonal.

It is sometimes appropriate for a window guard to be located internally, although this can make cleaning of an inward opening window difficult. Should an internal guard be considered, a laminated glass guard is unobtrusive and may be appropriate in some circumstances.

#### *5. Building maintenance*

Health and safety is a complex issue and the Health and Safety Executive has published guidance which is available on their website. Under the CDM Regulations, designers have to ensure that the design of the conversion does not cause unnecessary danger to those who will build, maintain and repair the building. Employers of tradesmen and craftsmen, who will be carrying out the conversion and maintenance of the building in the future, face increasingly tough guidelines and the opportunity should be taken during a building conversion contract to improve safe access to all parts of the building to enable the building to be properly altered and maintained in the future.

A range of specialist equipment is available including roof anchors, horizontal lifeline systems, and fixed vertical ladders with safety systems and edge protection. Whenever these are suggested for installation on listed buildings designers should seek specialist advice to ensure that the system proposed is appropriate to the location. A system suitable for one particular situation may be impractical elsewhere. The impact of fixings into the historic fabric should be considered in visual terms and in relation to the damage that may be done to the fabric itself. Any access and safety system that is installed will need to be fully tested and regularly inspected to comply with all current legislation.

While not a requirement of the Building Standards, safe access in order to clean and paint cast iron gutters and downpipes where, for example, a person could fall a distance of 2m or more may involve the use of fall arrest equipment and, possibly, high-level specialists. A wide range of fall arrest blocks for rope and wire rope, both manual and automatic, are available, as well as a variety of harnesses, lanyards, karabiners, shock absorbers, connectors and snap hooks. Specialist advice is required to specify descenders and ascenders for rope work. All equipment must comply with European Standards and carry the CE mark.

Ladders and their method of use should comply with HSE guidelines. Ladders may only be used for short duration tasks. The operative must have sufficient protection equipment and maintain three points of contact on the ladder.

Ladder-safe equipment is available to stop outward slip, reduce bounce, ensure the correct ladder angle and improve stability. At General Register House on Princes Street in Edinburgh, a specialist safety system (a continuous horizontal lifeline system with wire passing through carriers, with carriers mounted against lead inserts with welded joints to the existing lead to allow movement) was installed as a retro-fit round the main dome to allow safe access to clean the perimeter lead gutter (Illus 4.8.1). Ladder ties to the building secure a removable ladder, which hangs on an adjacent wall. Access to the gutter is by means of a removable ladder, which when not in use hangs on an adjacent wall. Ladder ties to the building secure the ladder while it is being used to provide access to the gutter.



*Illus 4.8.1 Continuous horizontal lifeline fixed to lead-work at General Register House, Edinburgh (Photo: J Cunliffe).*

#### **4.8.5 Related standards**

Other related standards are:

- Standard 4.1 Access to buildings
- Standard 4.2 Access within buildings

# 5. NOISE

## 5.1 Resistance to sound transmission

### Standard 5.1

Every *building* must be designed and *constructed* in such a way that each wall and floor separating one *dwelling* from another, or one *dwelling* from another part of the *building*, or one *dwelling* from a *building* other than a *dwelling*, will limit the transmission of noise to the *dwelling* to a level that will not threaten the health of the occupants of the *dwelling* or inconvenience them in the course of normal domestic activities provided the source noise is not in excess of that from normal domestic activities.

#### Limitation

This standard does not apply to:

- fully detached *houses*; or
- roofs or walkways with access solely for maintenance, or solely for the use, of the residents of the *dwelling* below.

### 5.1.1 Type of standard

#### **Mandatory standard**

In the case of *conversions*, the *building as converted* must meet the requirement of this standard.

### 5.1.2 Commentary

The issue of sound insulation in the conversion of a building to dwellings, or in the conversion of a single dwelling into separate apartments, presents significant challenges to the designer. The recommendations set out in the Napier University Report (2005), *Improving the sound insulation in dwellings*, provide a good basis for meeting the requirements of this essential standard. The most common type of development for a historic building is its conversion into smaller residential units, which makes this standard particularly important.

Designers should recognise that as historic buildings are not of a standard design or construction, each building will display unique characteristics as far as sound transmission is concerned. The presence of hidden voids within the construction, back-to-back fireplaces and cupboards, gaps between construction elements in floors and walls and similar unpredictable features mean that to use standard sound-insulating construction, selected from manufacturers' product specification information sheets, may prove to be unsatisfactory when the conversion has been completed. The costs of post-construction remedial treatment will be significant, both in terms of direct labour and material costs and in the loss of time, which adds to development costs. It is therefore strongly recommended that a pre-conversion or deterministic sound test be carried out prior to the start of conversion work, ideally during the site survey process. The acoustic performance of the existing construction can then be established and problems defined, which will allow the design of tailored acoustic solutions and costs to be determined at an early stage in the project.

Planning of the accommodation can go some way to reducing noise nuisance, for example:

- a) Locate rooms of similar use above and below each other (living rooms and kitchens located above bedrooms are a major source of complaint).
- b) Arrange, if possible, for each apartment to occupy the full height of the building to avoid the need for sound insulation in separating floors: separating walls are required to resist airborne sound only. The treatment of a

separating floor to resist airborne and impact sound transmission can be particularly destructive to historic fabric.

Lightweight timber floors will tend to be the most commonly encountered floor type in the conversion of a historic building into individual flats or apartments. The guidance offered here will, therefore, place emphasis on how best to deal with this floor type, as these floors provide little sound insulation and will usually require substantial intervention to achieve a satisfactory performance.

Conversions of buildings with concrete and fireproof brick-arched floors are typically encountered where former warehouses, office buildings, hospitals etc. offer opportunities for conversion to flats. The mass of concrete floors generally provides good airborne sound insulation. The Napier Report advises that *'where the floor slab has a mass per unit area greater than 300kg/m<sup>2</sup> and a minimum thickness of 150mm, it is likely that airborne sound insulation will achieve the requirements of...the Building Regulations.'* However, impact sound insulation will require to be upgraded.

In the case of separating walls, existing masonry walls normally found in historic buildings, which are likely to be of either stone or brick construction, will normally meet sound insulation standards if they are over 215mm in thickness. Pre-1919, heavy, thick stone rubble walls perform well in sound tests. Walls below this thickness, for example half-brick thick with 30mm lath and plaster finish, will not achieve the required standard. A number of factors influence the sound insulation of party walls:

- joists spanning into separating walls (particularly thin spine party walls),
- flues, fireplaces, recessed cupboards and other recesses in separating walls provide concentrated weak spots for sound transmission,
- damage to lath and plaster finishes, or their replacement with plasterboard, reduces the acoustic performance of the wall,
- penetration of services,
- poor workmanship, such as partially filled mortar joints.

### 5.1.3 Issues to be considered

Issue	Risks to historic/traditional buildings
1. Flanking transmission	<ul style="list-style-type: none"> <li>• The major risk to historic buildings from flanking sound transmission is the need to provide sound insulation at external wall-separating floor junctions. The fire stopping at such junctions is also a factor. Sealing these junctions reduces or prevents air movement within cavities and behind dry linings and may lead to stagnant air conditions promoting raised moisture contents in adjacent timber. Prevention of conditions conducive to dry rot must be a priority.</li> </ul>
2. Separating floors	<ul style="list-style-type: none"> <li>• Potential loss of floor finishes when a floating floor is used to combat impact sound,</li> <li>• Alterations to historic doors (door heights and proportions) and wall finishes due to raised floor levels,</li> <li>• Potential loss of ceiling finishes and decorative features when an acoustic ceiling is installed,</li> <li>• Reduction in floor to ceiling heights may affect historic character,</li> <li>• Increased floor loading may mean structural intervention to strengthen floor,</li> <li>• Reduced air movement in voids (see above).</li> </ul>
4. Separating walls	<ul style="list-style-type: none"> <li>• The risks are mainly associated with lightweight or slender party walls where the application of sound insulation will mean loss of existing finishes and changes in room dimensions.</li> <li>• The application of acoustic wall lining to lightweight common access stairs where a large house, for example, is converted to flats can mean the loss of decorative cornicing to both sides of the wall.</li> <li>• Blocking up of doorways that are no longer necessary. False openings, however, can be constructed within the acoustic wall to house the original door and its architraves.</li> </ul>
5. Ventilation of voids	See 1. above.

**5.1.4 Recommendations to meet the standard**

In many situations where a building is being converted into a number of separate apartments, alterations to the floor to improve the sound insulation will almost certainly be required if the standard is to be met. Where the historic importance and character of the construction is such that the loss of features is unacceptable, this form of development may not be a viable option for the building.

Upgrading an existing separating floor, which may or may not already have some form of sound insulation, for example ash pugging, will not be a common requirement in a conversion involving a change of use and is not addressed here. This guide concentrates only on separating floors in buildings being converted to flats or apartments and separating walls.

The Building Standards identify three means of meeting the standard, refer to Part I, Section 6.2.2 of this guide for further information:

- a) Specified constructions (walls and floors),
- b) Performance testing and
- c) Robust Details Scheme

The use of specified constructions is not usually directly applicable to conversions (especially of historic buildings) and is essentially designed for new build, but may be adopted for some separating-floor situations. The Robust Details Scheme does not cover conversions or alterations. To satisfy the standard it will normally be the case, that due to the unique nature of historic buildings, performance testing will be required. This should include pre-conversion testing of the existing construction, so that sound insulating construction is designed that will cause least disruption to historic finishes, and post-conversion testing of the completed conversion.

The details illustrated below are for guidance only and may have to be amended to suit particular site conditions.

**Separating floors**

*Timber separating floor*

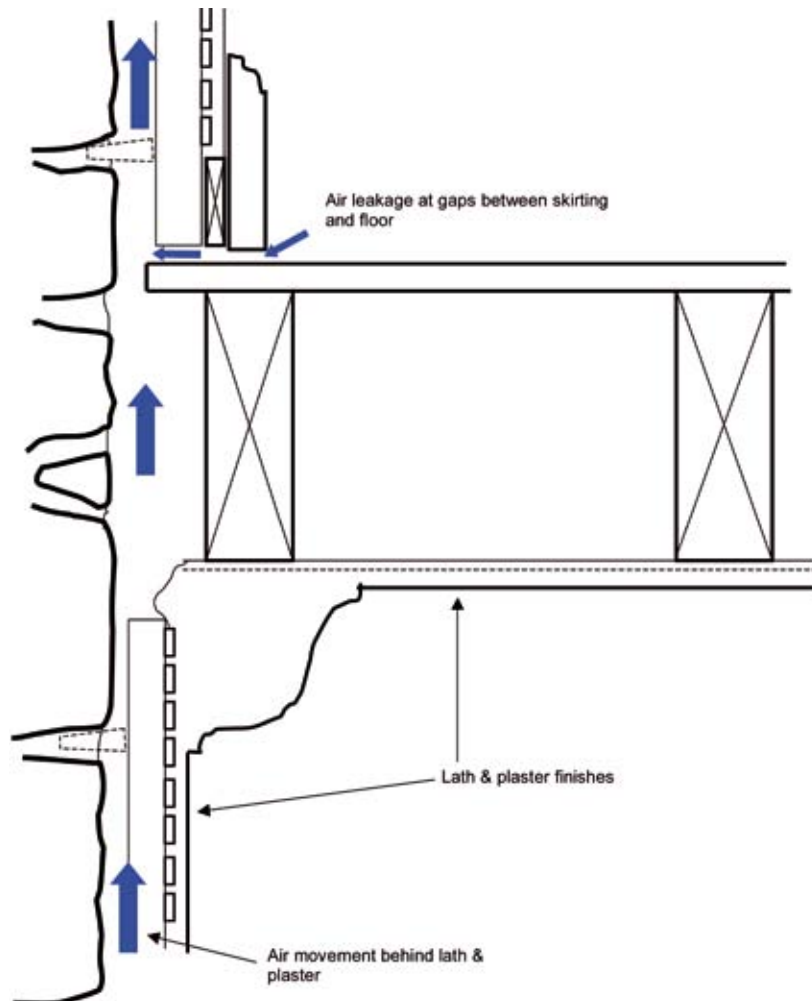

*Illus 5.1.1 A historic timber floor that is to become a separating floor.*



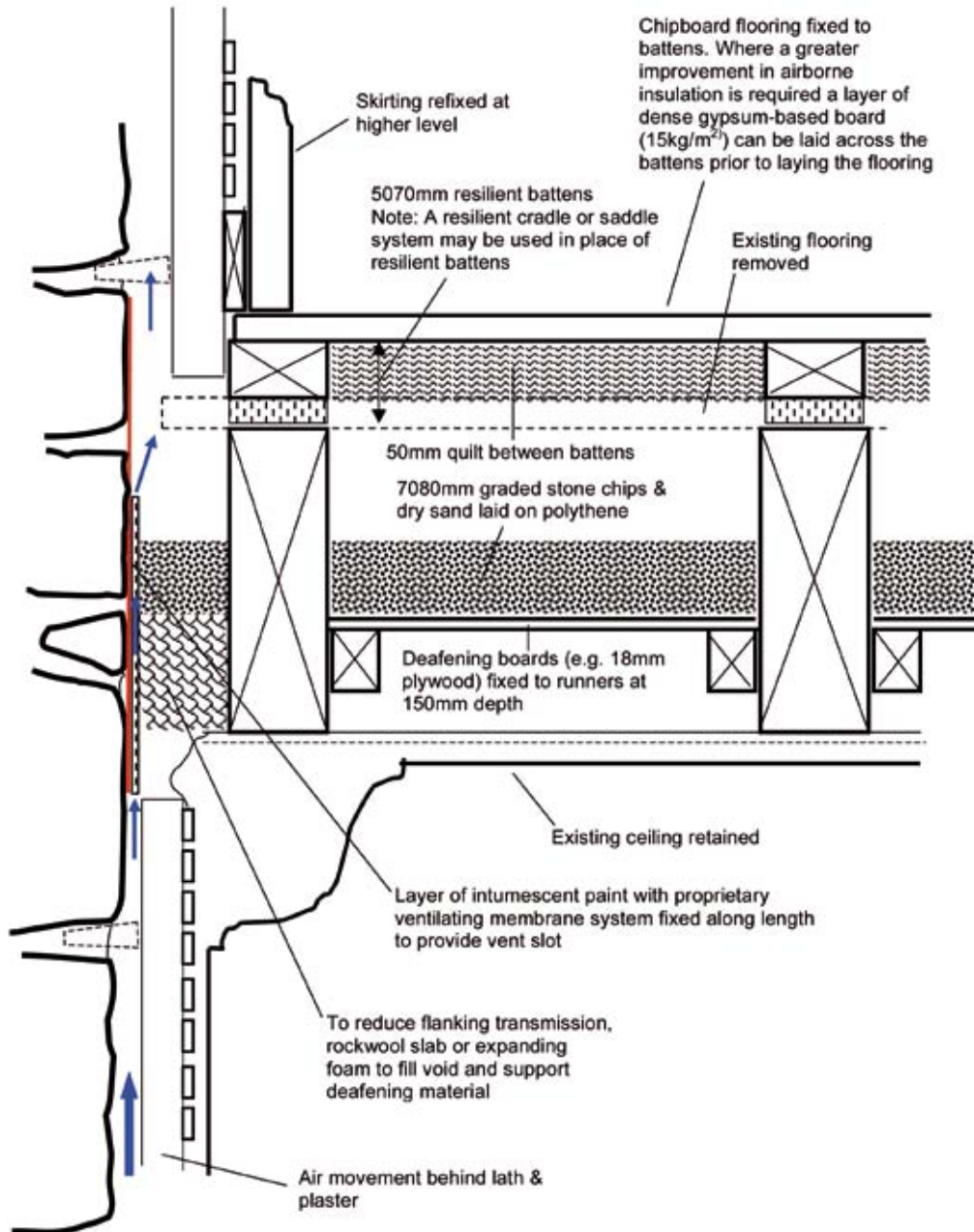

*Illus 5.1.2(a) Sound insulation of existing timber floor using resilient battens where the floor level can be raised. Note: the use of an intumescent strip and vent slot at wall floor junction, as shown here, will only be acceptable with a very narrow gap and the construction passes a sound insulation test.*

Notes associated with Illus 5.1.2(a).

- a) The floor level has been raised and will present problems at internal doors, which will have to be reduced in height.
- b) The entrance door to the apartment will require a shallow ramp to be constructed inside the entrance to accommodate a possible difference in floor level between the common access and the apartment.
- c) The use of heavy-weight granular material between the joists will be possible only where the timber floor structure can carry the additional loads.

- d) Sealing the junction between wall and floor will reduce flanking sound transmission and act as a fire stop. However, there is the potential to create stagnant air voids behind the plasterwork and skirting-level where ventilation may have to be introduced to maintain a low level of air movement. **The use of a proprietary ventilating membrane, as shown here, is a source of weakness in the sound insulating properties of the floor.** This construction will be acceptable only if it passes appropriate sound tests.

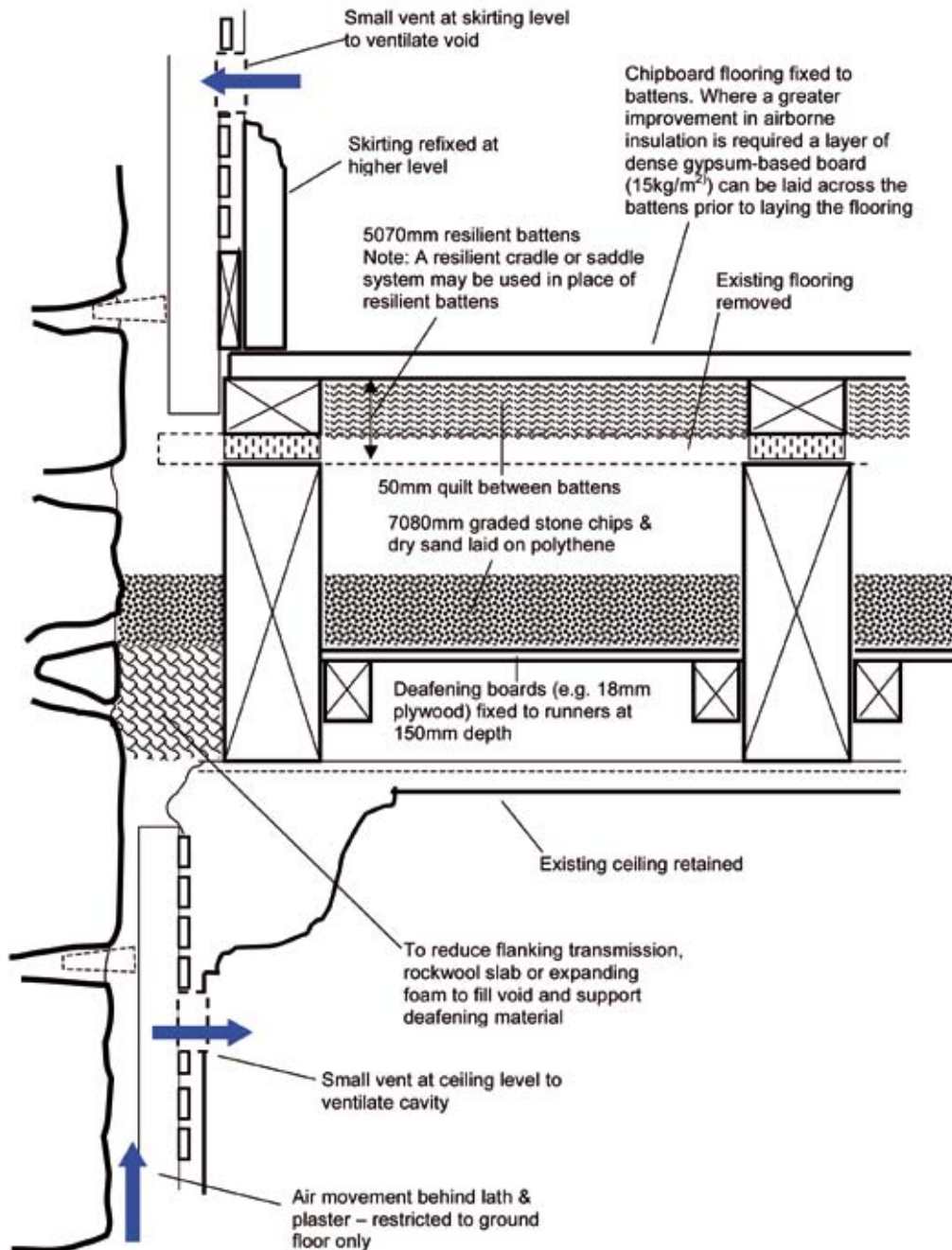

Illus 5.1.2(b) Alternative floor-wall junction to that shown in Illus 5.1.2(a). Note the air-tight seal at floor perimeter and the use of vent slots at ceiling and skirting level to permit ventilation of void behind lath and plaster.

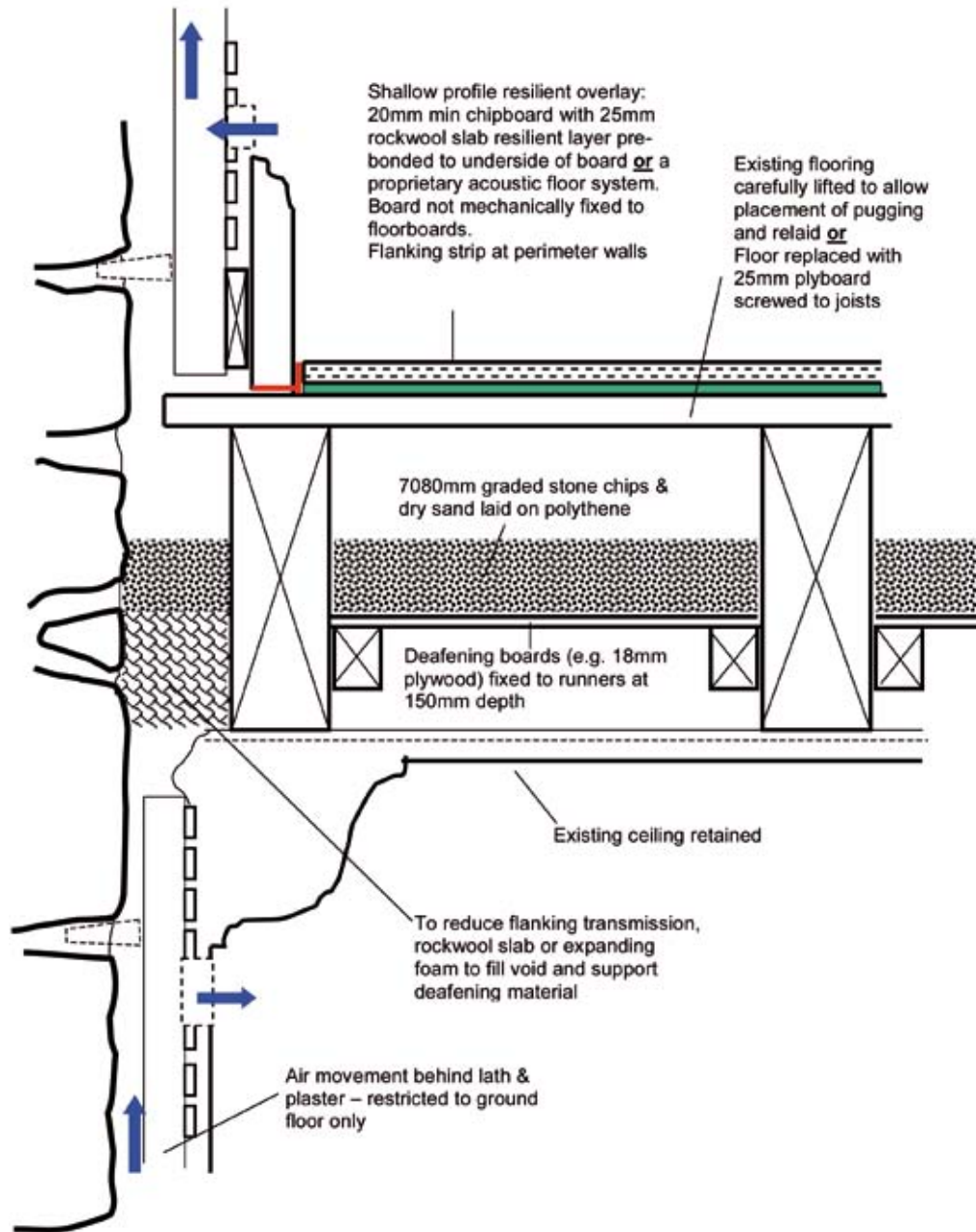

Illus 5.1.3 Alternative floor finish using a resilient layer to minimise the increase in floor level and retain the existing ceiling.

Notes associated with Illus 5.1.3.

- a) The use of a resilient layer on top of the existing flooring may, when combined with other sound insulating measures, provide a minimum level of impact sound insulation **and will be the preferred option for most timber floor situations.**
- b) The resilient overlay should not be screwed or nailed to the flooring.
- c) A resilient flanking strip must be installed at the perimeter of the overlay at the junction with skirting or wall.

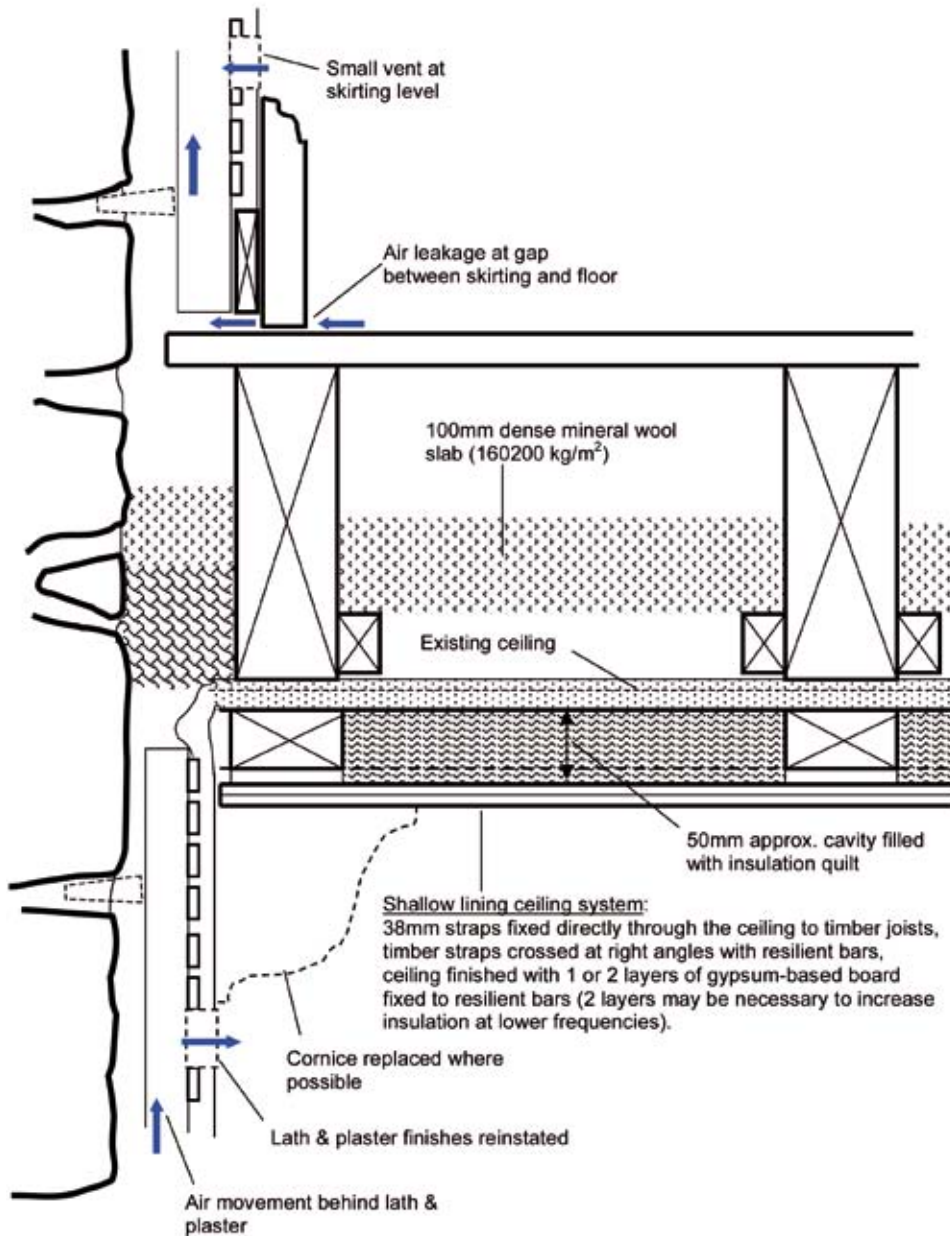

*Illus 5.1.4 Sound insulation of existing timber floor with reduced ceiling height.*

Notes associated with Illus 5.1.4.

- a) This system is used where an alteration to the floor level cannot be accommodated.
- b) The dense mineral wool insulating slab may be used where additional imposed loads must be kept to a minimum.
- c) The existing ceiling is retained (where it is in sound condition).
- d) The shallow lining ceiling system will reduce the floor to ceiling height by approximately 70–75mm.
- e) Existing plaster work to walls is reinstated and any feature cornices that have to be removed are replaced with a matching replica cornice, run in situ.
- f) Alternative ceiling treatments are suspended from an independent frame. The independent frame provides the most substantial level of improvement.

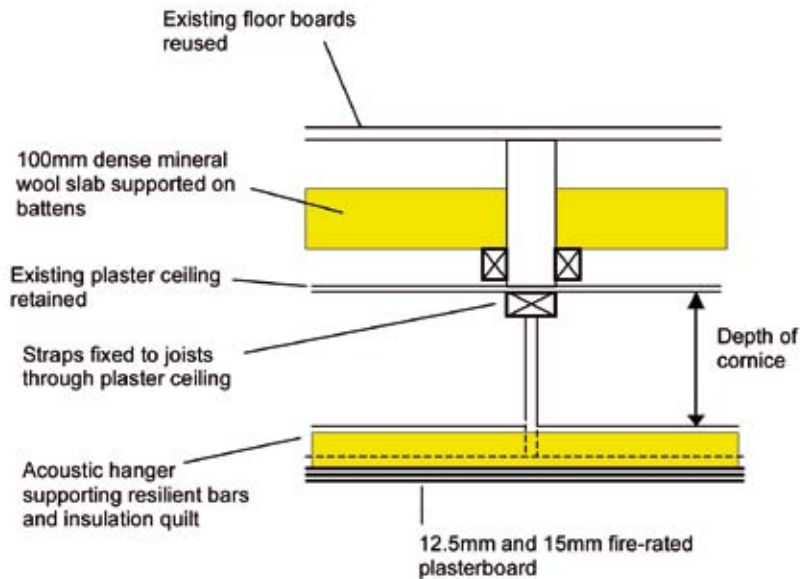

*Illus 5.1.5 Lowered acoustic ceiling to cover but retain historic finishes.*

Where an existing ceiling contains important features that have to be retained (Illus 5.1.5), such as ornate cornices, but where the installation of a sound insulating ceiling would result in their loss, an acoustic ceiling system using acoustic hangers may be adopted as a reversible measure if all other options are first explored. This is a form of suspended ceiling in which the existing ceiling, together with its important features, is retained in place but covered by a new ceiling suspended below the cornice level using an acoustic hanger support system fixed to the joists through the plaster lath. While the original ceiling is lost from view, it remains in place and may be exposed at a later date should the use of the building change. However, such an approach may be only possible where there is sufficient height between the head of a window opening and the cornice to accommodate the new ceiling. Where it is possible to raise the level of the floor, the preferred solution, which retains in view the important ceiling features, is shown in Illus 5.1.3.

#### *Concrete separating floors*

Concrete separating floors are often encountered in the conversion of historic buildings: typical examples being the conversion of industrial, warehouse and office buildings into flats dwellings. With respect to noise transmission, the conversion of such buildings may be less disruptive to historic fabric than the conversion of other types of historic buildings, due to the normally high floor-to-ceiling heights, the utilitarian nature of floor and ceiling finishes and the inherent structural strength and stability of the floor.

Floors will generally have adequate airborne sound insulation but improvements will be required to the impact sound insulation. A number of options are available to improve impact performance:

- a) Where there is a restricted floor-to-ceiling height, a resilient floor overlay, as described in Illus 5.1.3, can be laid on the concrete floor surface. However, any gaps within the concrete floor construction must be sealed up, to reduce airborne transmission, before the overlay is placed.
- b) Where the floor-to-ceiling height is not an issue, a floating floor, consisting of chipboard set on resilient battens as shown in Illus 5.1.6, may be constructed on top of the concrete slab. This is the preferred method and has the added advantages that the floor can be levelled and services can be accommodated within the floor void. Impact resistance is also better than for the resilient overlay system.
- c) If the concrete slab does not provide the required level of airborne sound insulation, the installation of an acoustic ceiling system will be necessary, such as the shallow lining ceiling system shown in Illus 5.1.4.

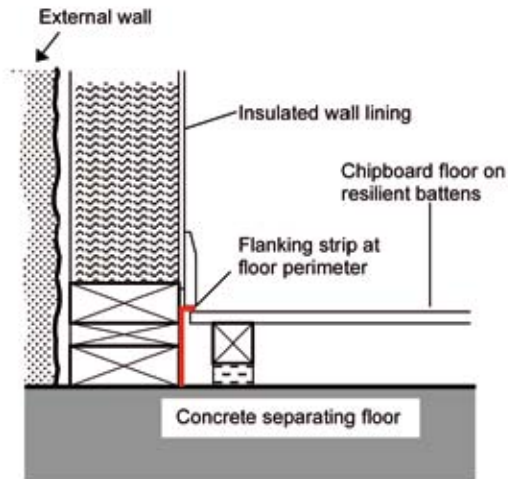

Illus 5.1.6 Floating floor on existing concrete slab.

*Separating walls*

Masonry separating walls over one brick (215mm) in thickness will generally provide sound insulation that will meet the requirements of the Building Standards, provided that there are no open joints in the masonry and the plasterwork is sound.

Masonry walls that are less than 215mm in thickness, for example a half-brick wall plastered 'on the hard' or with lath and plaster, will not meet the required standard of sound insulation. Any remedial treatment to improve sound insulation will necessitate the use of a mineral fibre backed board, resilient wall lining or the construction of a free-standing partition on one side of the wall (as shown in illus 5.1.7), which will encroach into the room and result in loss of original finishes and features.

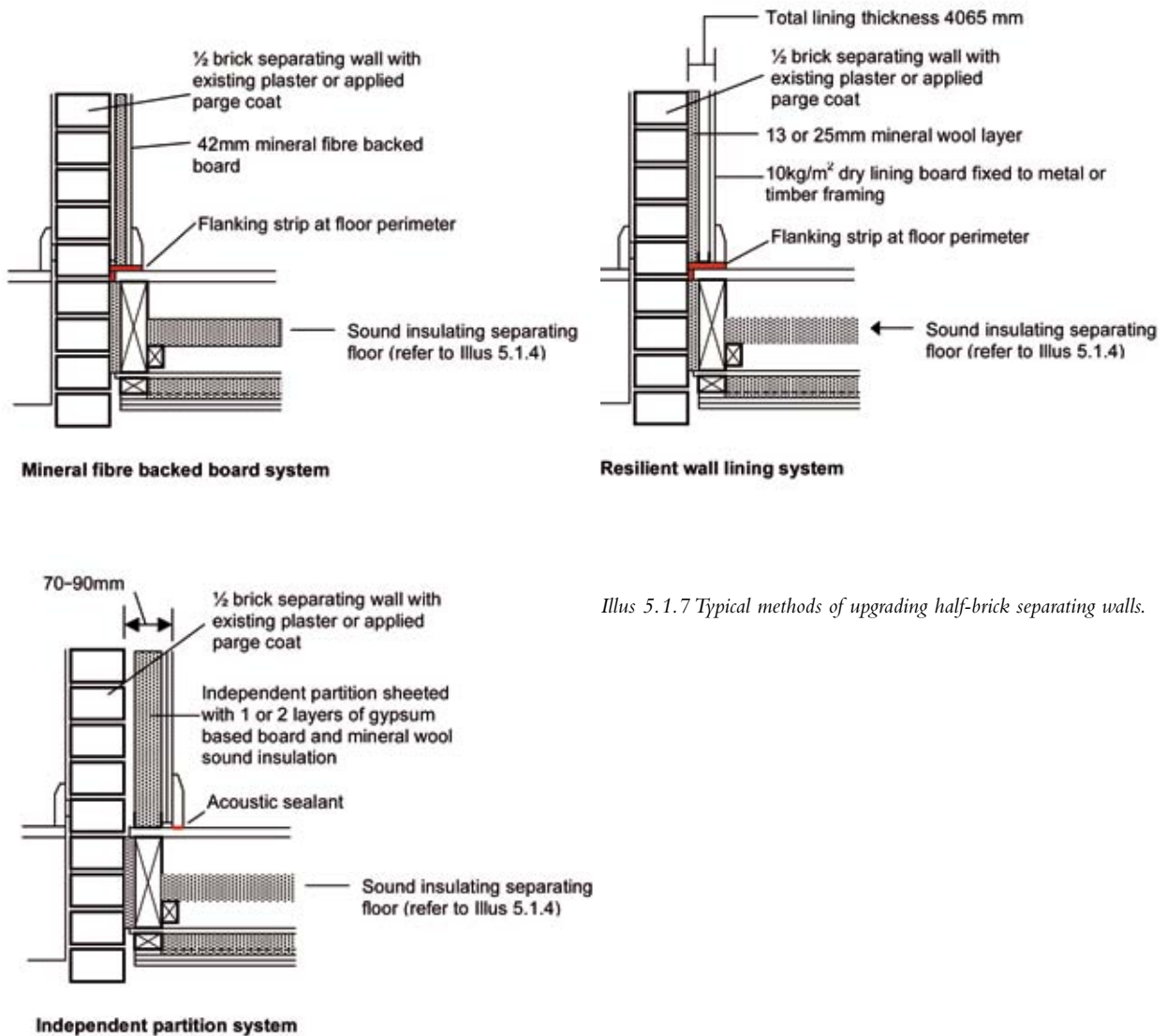

Illus 5.1.7 Typical methods of upgrading half-brick separating walls.

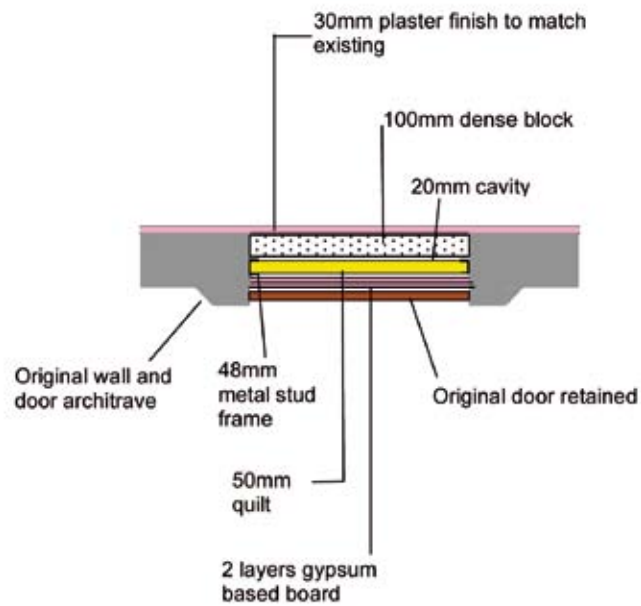

*Illus 5.1.8 Blocking up an existing door opening in a wall that is changed to a party wall (from Napier University Report 2005).*

Illus 5.1.8 is an example of a door opening in what is now a party wall. The door is to be retained as a feature, complete with all the original features, and the in-fill to the door opening on the other side is matched to the existing finish. In this example the airborne test performance was 54 dB DnT,w.

#### **5.1.5 Related standards**

Other standards that may be influenced by this standard, or which may have an influence on this standard are:

- 1.1 Structure
- 2.2 Fire separation
- 2.3 Structural protection
- 2.4 Concealed spaces
- 3.14 Ventilation (air movement in voids)
- 3.15 Condensation
- 4.2 Access within buildings (thresholds)

## 6. ENERGY

### 6.1 Policy

#### Standard 6.1

Every *building* must be designed and *constructed* in such a way that provision is made for energy conservation in accordance with the Building Standards Circular on Energy, 2004.

#### 6.1.1 Type of standard

##### *Mandatory standard*

In the case of *conversions*, the *building as converted* must meet the requirement of this standard.

#### 6.1.2 Commentary

This standard sets out the thinking underlying all the standards within the Energy section of the Building Standards, where the aim is to achieve a total saving in terms of carbon emissions. The application of the standards is designed to achieve a 25% improvement on the energy performance of buildings as required by 5th Amendment to the 1990 Building Standards Regulations. Standard 6.1 therefore requires that '*new buildings, conversions, extensions to buildings and alterations should be designed and constructed so that the energy performance is 25% more efficient than would have been the case if the construction or conversion had been under the standards in force on 3 March 2002.*'

This standard, as worded, does not seem to provide the opportunity to allow a reduction in the standard when addressing the conversion of a traditional building. There are therefore potentially serious implications for the building if the prescribed levels of envelope insulation have to be implemented. However, the idea that this is a standard that must be met has been included to set a level of performance and to make all the other standards in the Energy section (Section 6) apply. It is considered that the wording of this standard is in essence couched in terms of a national objective.

The intention of the Scottish Building Standards Agency, with respect to the conversion of historic buildings, is that Schedule 6 will allow the energy standards to be applied to conversions in a flexible way. In other words, in the case of conversions, a common sense approach to this standard, while requiring improvements to be made as close as reasonably practicable, will recognise the need for protection of historic character. Annexes 6H (Alterations and Extensions) and 6N (Conversions) of the Building Standards make specific reference to historic buildings and stress that each case will have to be dealt with on its own merits. This approach may reduce the impact of the 25% improvement in energy performance requirement over the standards in force on 3 March 2002 for some conversions, but should be compensated by others. However, it is important to recognise that, although standards 6.2 to 6.6 can be viewed with a degree of flexibility, in the application of all standards a 'do nothing' approach should not be considered as the starting point. It is only in very exceptional cases that the use of innovative and practical solutions on energy efficiency will not be able to be incorporated to provide an overall improvement in performance. Therefore, the opportunity exists within Section 6 to address the conversion of a traditional building in a holistic way, which will result in an alternative package of energy measures that will provide improvements in energy efficiency.

For further advice on methods of achieving energy savings in the conversion of historic buildings, reference should be made to the following sections contained within Part II, Section 6, Energy. The under noted points summarise some of the key considerations:

- a) A detailed assessment of the energy performance of the existing building, prior to conversion, is



recommended so that a holistic energy plan for the conversion of the building is established. This plan should be read in conjunction with the conservation plan before the detailed design is completed, to ensure that the historic character of the building is retained.

- b) All new buildings or conversions of existing buildings for which warrant applications are submitted after May 2007 will require *energy certificates*. This is a requirement of Article 7 of the Energy Performance in Buildings Directive 2002/91/EC, in which buildings are required to have energy ratings produced using national calculation methodologies. For dwellings, a reduced version of the Standard Assessment Procedure (SAP) will be used. This requirement for an energy performance certificate will also apply to the conversion of historic buildings where the total useful floor area is over 1000m<sup>2</sup>.
- c) The insulation of the building envelope will, in most cases, fall short of the requirements set out in the Standards (Annex 6N2) and emphasis will have to be placed on improvements to energy efficiency and carbon emission reductions in other areas. It is appropriate to recognise that for many conversions – such as for residential and commercial buildings – modern standards will be expected by users. For some other types of buildings, or parts of a building, a less demanding standard of comfort (and therefore energy use) may be acceptable; for example parts of a building used for display or storage.
- d) Energy efficiency measures are likely to include;
- improvements to envelope insulation where this can be achieved without loss of historic fabric,
  - zoning of buildings for heating to reflect use and orientation of spaces (taking account of the effect of solar gain),
  - high-efficiency central heating boilers with a minimum SEDBUK rating of band A for domestic buildings,
  - controls on boilers, emitters and hot water systems to manage effectively temperature and operational timing,
  - reduced pipe runs to hot water installations whenever possible and consider the use of local water heaters – usually most appropriate for buildings with low/intermittent occupancy,
  - efficient insulation of pipes and hot-water vessels,
  - installation of energy-efficient ventilation,
  - avoiding the installation of air-conditioning systems whenever possible (to save energy use and to avoid damage to historic fabric),
  - use of dedicated energy-efficient lighting (fittings may, however, be incompatible with the historic character of the building),
  - Use of renewable energy sources where appropriate (refer to the Energy Saving Trust for further information).

The constraints imposed by a traditional building on energy saving measures will affect the choice of options available – options that would be normal in a new-build situation.

From May 2007:

The whole of Section 6 is being rewritten. Standard 6.1 will no longer apply to conversions, but the other standards in this guidance will apply, as will two additional standards. For details see comments after each standard in this section. The general comments made in this guidance remain applicable

### **6.1.3 Related standards**

Other related standards are:

- Standard 3.13 Heating
- Standard 3.14 Ventilation
- Standard 3.15 Condensation

- Standard 6.2 Envelope insulation
- Standard 6.3 Heating systems
- Standard 6.4 Insulation of pipes and ducts
- Standard 6.5 Artificial and display lighting
- Standard 6.6 Mechanical ventilation and air conditioning.

## 6.2 Building envelope insulation

### Standard 6.2

In order to comply with Standard 6.1 every *building* must be designed and *constructed* in such a way that the *insulation envelope* resists thermal transfer.

#### Limitation

This standard does not apply to:

- buildings*, other than *dwelling*s, which will not be heated nor cooled, other than heating provided for the purpose of frost protection; or
- buildings* which are ancillary to a *dwelling* which will not be heated, other than heating provided for the purpose of frost protection.

### 6.2.1 Type of standard

#### Reasonably practicable standard

Every *conversion*, to which these regulations apply, must be improved to as close to the requirement of the standard as is *reasonably practicable*, and in no case be worse than before the *conversion*.

### 6.2.2 Commentary

Refer to Commentary in Section 6.1.2, which provides an overview of the approach to this standard.

While Standard 6.2 is concerned with new building work and consequently the design of the insulating envelope of new buildings, it nevertheless offers considerable flexibility in how the standard will be met. The wording of the standard, and the associated Annexes 6H (Alterations and Extensions) and 6N (Conversions), will mean that, in nearly all situations involving the conversion of historic buildings, it will be possible to allow a reduction in the thermal transmittance of the envelope in exchange for a heating system with improved energy efficiency. The approaches specified in the standards for domestic and non-domestic buildings, Elemental Method, Target U-value Method (domestic), Heat Loss Method (non-domestic) and the Carbon Index Method are applicable only to new buildings and are not appropriate for use in the conversion of historic buildings. In most cases, upgrading of fabric insulation will be done on an elemental basis, only upgrading where it can either be hidden or accommodated in keeping with the historic nature of the building and where there is very little or no technical risk associated with the work.

When considering the envelope insulation it is possible to consider the potential reduction in carbon dioxide emissions and energy efficiency benefits that can be achieved by

- high efficiency central heating boilers with a minimum SEDBUK efficiency as defined in Table 2 of the standard,
- including solar heat gains,
- community heating schemes,

- photo-voltaic systems<sup>†</sup> (will need to be carefully located in consideration to their impact on historic buildings),
- wind-power generated electrical heating (Note: wind power is unlikely to be used for electric heating unless the turbine is substantial and, if used, will need to be carefully located in consideration to their impact on historic buildings),
- energy efficient artificial lighting and air conditioning systems,
- solar water heating,
- heat pumps etc.

It is thus important to think about the building in a holistic way and adopt an integrated approach that considers the interaction of insulation, heating (including solar gains) and ventilation in providing satisfactory internal conditions and improving energy efficiency. Improvements to envelope insulation should not consider each element in isolation, as improvements to one element may lead to surface temperature differentials with an adjoining element and result in cold bridging and related condensation problems. The application of internal insulation to walls should be considered only when little or nothing of historic importance survives.

In the majority of buildings, the least problematic means of improving the envelope insulation is by applying insulation at roof level. For pitched roofs with ventilated roof spaces (cold roof), it will not be practicable to install a vapour check on the warm side of the insulation (unless it is to an inclined roof surface in an attic room), which makes efficient roof-space ventilation essential if moisture levels in the roof are to be controlled. However, for flat and low-pitched roofs improving insulation may be more difficult.

Most historic flat and low-pitched roofs are covered with lead, but copper and zinc coverings are also encountered. Providing that these historic metal coverings and the supporting decks are in sound condition they should be retained, which will reduce the options available for improving the roof insulation. Frequently, however, repairs and replacements to such roofs have involved the use of felts and bitumastic materials, which are not compatible with the metal roof coverings or the historic character of the roof. In this case, the opportunity is available to both improve the thermal performance of the roof and reinstate the roof covering with a more sympathetic material. Historic flat roofs have a variety of designs and many are contained behind an upstand parapet or blocking course that may influence the design and construction of applied insulation, especially roof ventilation. Most historic flat roofs may be described as 'cold roofs', having a small roof space that may or may not be ventilated (apart from fortuitous air leakage).

Upgrading the insulation of a flat roof using a cold roof design, where the insulation is placed at ceiling level, is not normally the best option. Stirling (BRE 2002) makes the following points:

- *'The cold deck roof is a poor option in the temperate, humid climate of the UK, where sufficient ventilation may not be achieved in sheltered locations or in windless conditions, even when the roof is correctly designed.'*
- *'It is usually not possible to upgrade the thermal insulation value of an existing cold deck roof. The preferred option is to convert it to a warm deck flat roof.'*

To be effective, a cold roof must have efficient cross-ventilation, which usually means open eaves-type vents at each end of the roof span. Ventilation of this form is therefore extremely difficult to achieve if the roof is contained within parapets or abutment walls. The fact that historic lead roofs of this type have survived for centuries with little (usually fortuitous) ventilation does not mean that insulation may be installed with impunity. Adding insulation and increasing roof ventilation can upset the previous balanced environment within the roof space, increase the moisture content of roof timbers and induce corrosion of the lead.

Stirling (2002) recommends either a warm deck or an inverted warm deck flat roof construction. Ventilation is not required as the insulation is bedded on a continuous vapour control layer. This type of construction works well with modern felt and asphalt roof membranes, but where a sheet metal roof covering is used 'thermal pumping' effects can occur where moisture is drawn into the sandwich resulting in decay of timber and underside lead corrosion (ULC). The problem of ULC is described in the English Heritage and Lead Sheet Association advisory note (1997). The thermal upgrading of a metal-covered flat roof needs great care and the Lead Sheet Association recommends the use of a ventilated warm roof, with the creation of a new insulated and ventilated roof deck structure that is completely isolated from the underlying structure. However, there will be situations where the raised roof level will not be acceptable, either because it will obstruct another roof feature or where detail and appearance are important.

<sup>†</sup> For further guidance on micro-renewable systems refer to Scottish Executive PAN 45 Planning for micro-renewables.

From May 2007, draft amended standard 6.2 is:

Every *building* must be designed and *constructed* in such a way that an insulation envelope is provided which reduces heat-loss.

Limitation

This standard does not apply to *buildings* and to *ancillary buildings*, other than conservatories, which will not be heated other than by heating provided solely for the purpose of frost protection.

The guidance offered remains applicable.

**6.2.3 Issues to be considered**

When considering the application of the energy standards to historic buildings, the potential impact of increased insulation, reduced ventilation rates and more tightly sealed buildings, resulting in possible timber decay, should be considered. These effects may create a potential conflict with other aspects of the regulations, for example, Regulation 8 Durability and Section 3 Environment.

Issue	Risks to historic/traditional buildings
1. Improving insulation to walls	<p>Externally applied insulation.</p> <ul style="list-style-type: none"> <li>• As the external appearance is one of the most important features of a traditional building, the application of externally applied insulation systems will change the character of the building and will not be acceptable in most situations.</li> <li>• Moisture transpiration to external air will be reduced and may cause raised moisture levels in embedded timbers.</li> </ul> <p>Internally applied insulation.</p> <ul style="list-style-type: none"> <li>• Loss of historic finishes such as plaster, paint, panelling and mouldings.</li> <li>• Dimensional changes to room sizes may affect historic character.</li> <li>• Applied insulation at window and door openings may affect features such as shutters, window and doorframe dimensions.</li> <li>• Reduced thickness of insulation (or no applied insulation) at openings and junctions can produce thermal bridges.</li> <li>• Incorporation of vapour checks and reduction (or elimination) of air movement behind the insulation can trap moisture within the construction.</li> <li>• Sealed construction as a result of applied insulation and draught stripping of doors and windows can reduce levels of ventilation leading to higher vapour pressures in rooms and an increased risk of interstitial condensation.</li> <li>• Very few historic buildings will have cavity walls, and while envelope insulation will be improved by the insertion of cavity fill insulation, this may increase the risk to construction of this type through moisture transfer from the outside and interstitial condensation from the inside, leading to wall-tie corrosion.</li> </ul>

<p>2. Improving insulation to roofs</p>	<p>Pitched roof: ventilated roof space.</p> <ul style="list-style-type: none"> <li>• Improved insulation at ceiling level results in a colder roof space and increased risk of condensation.</li> <li>• Insulation may reduce air infiltration at eaves.</li> <li>• In low-pitched roofs additional ventilation has the potential to further reduce roof space temperature without reducing sufficiently the humidity level of the roof space to control condensation.</li> <li>• Installation of roof ventilators can affect the appearance and character of the roof.</li> </ul> <p>Pitched roof: sarking level insulation.</p> <p>Used where rooms are provided within the roof space.</p> <ul style="list-style-type: none"> <li>• For a traditional building with a slate or tile roof, the installation of insulation within the depth of the rafters will be destructive to existing internal finishes.</li> <li>• The provision of additional roof vents at wallhead level to ventilate the space above the insulation may be difficult to achieve without adversely affecting the historic character of the wallhead detail.</li> <li>• Modern roof vents for slated roofs will be aesthetically damaging when installed in a historic roof structure.</li> <li>• Where the roof is penetrated by dormer windows or rooflights, maintaining airflow over insulation may be difficult.</li> <li>• Modern roof insulation details may be acceptable only when applied to the conversion of utilitarian buildings and attic spaces.</li> <li>• Sprayed insulating foams can lead to decay of timber and prevent reclamation of slates and tiles – not recommended for historic buildings.</li> </ul> <p>Flat roof: cold roof.</p> <ul style="list-style-type: none"> <li>• Underside lead corrosion.</li> <li>• Introduction of ventilation may be damaging to appearance.</li> <li>• Installation of insulation will normally require removal of ceilings.</li> </ul> <p>Flat roof: warm roof</p> <ul style="list-style-type: none"> <li>• Removal of the original (historic) metal covering.</li> <li>• Raised roof level can affect appearance and detail.</li> </ul>
<p>3. Improving insulation to floors</p>	<p>Solid floors.</p> <ul style="list-style-type: none"> <li>• Traditional floors such as flagstone, brick etc cannot be insulated without lifting, excavating to a new level and relaying the original finishes on rigid insulation and DPM. This should generally be avoided unless required to remedy an existing defect.</li> <li>• Installation of a damp proof membrane can drive moisture up porous walls at the perimeter of the floor.</li> <li>• The only practicable method of insulating an existing concrete floor is to add insulation to the top of the concrete and a new floor deck: the raised floor height means adjustments to doors and wall finishes. Unequal step heights at stairs and raised thresholds at doors are likely to be unacceptable.</li> </ul> <p>Suspended floors.</p> <p>In most situations, the installation of underfloor insulation will be possible and is a key method of improving envelope insulation.</p> <ul style="list-style-type: none"> <li>• Possible damage to existing flooring if insulation cannot be applied from below. Some types of historic boards cannot be lifted and re-laid without damage.</li> <li>• Ventilation pathways may be sealed off, particularly at the perimeter walls where air movement behind lath and plaster is required. Underfloor ventilation must be checked.</li> <li>• Lifting floorboards may affect the structural integrity of the floor where the flooring acts as a structural membrane.</li> </ul>

<p>4. Windows</p>	<p>The standard of insulation recommended for windows cannot be achieved with historic sash and case timber windows or metal windows.</p> <ul style="list-style-type: none"> <li>• Draught stripping existing windows and sealing gaps around windows can reduce ventilation rates within rooms and hidden voids.</li> <li>• Installation of secondary glazing can be visually unacceptable and/or may adversely affect internal finishes.</li> <li>• In most historic buildings the use of thermally efficient double-glazing in replica sash and case or casement windows will result in unacceptably thick glazing bars and frames.</li> <li>• Modern replacement windows, whether timber, PVCu or aluminium, are not appropriate for historic buildings.</li> <li>• Improved envelope insulation can lead to increased condensation on single glazed windows and encourage wet rot in timber frames.</li> </ul>
<p>5. Reduced air infiltration</p>	<p>See notes in Issues 1 to 4 above.</p>

**6.2.4 Recommendations to meet the standard**

While this is a standard that must be achieved to as close as is reasonably practicable, and therefore gives a degree of flexibility in its compliance, it provides significant challenges to the designer of a conversion. The aim is to improve envelope insulation without loss or damage to building fabric that is of historic value. The advice contained in the following diagrams and descriptions cannot cover all situations but addresses the issues outlined in Section 6.2.3 above. In addition, the broad guidance contained within Annex 6N (6N3, *Conversion of historic buildings*) of the Technical Handbooks are relevant to assessing the level of fabric insulation (if indeed any) necessary to comply with standards.

*Note: The details given below are composite details and are not confined to advice on envelope insulation alone. They are designed to show the interaction of issues such as insulation, ventilation, moisture transfer etc. with historic construction. For this reason, key junctions of walls and ground floors, and walls and roofs are provided to enable the reader to fully appreciate the combined influence of various standards. The details, where relevant, are repeated in other parts of the guide.*

**Walls and floors**

*Illus 6.2.1(a) Insulation of a wall with no pre-existing historic finishes and treatment of a traditional stone flag floor. Note: This illustration is relevant to a situation where a traditional flagstone floor has to be retained. No insulation has been added and improvements to energy conservation are achieved elsewhere.*

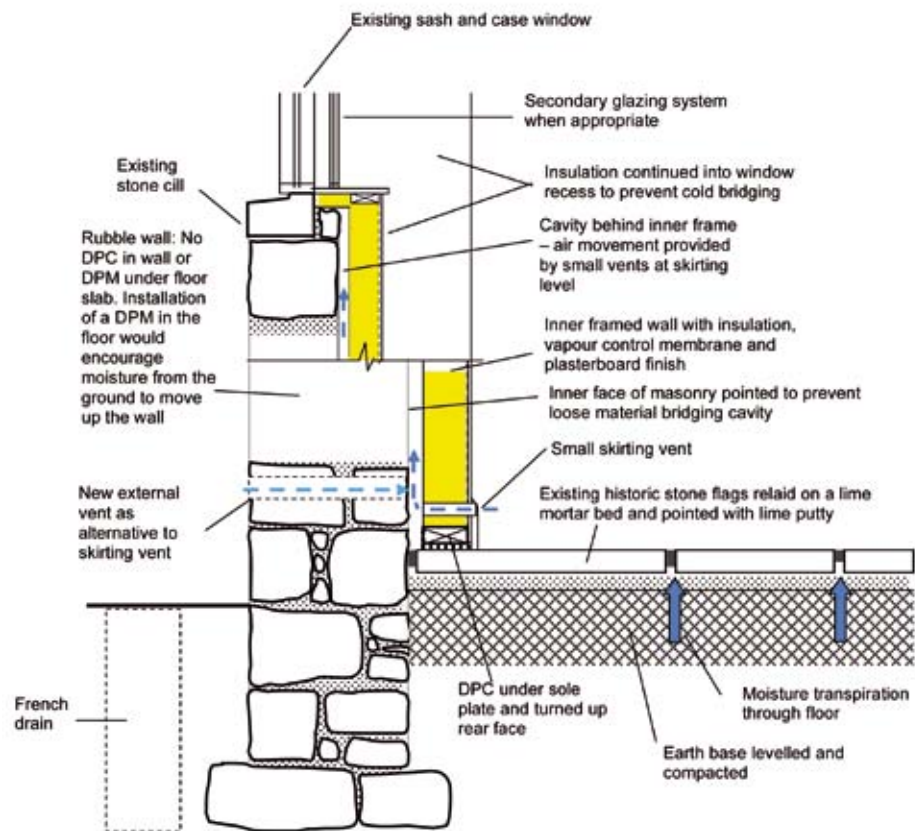

Notes associated with Illus 6.2.1(a).

- i. The insertion of a DPC within the wall is not recommended.
- ii. No DPM is inserted under the re-laid stone-flag floor to prevent excessive moisture rise within perimeter walls. Installing insulation below this floor will require the use of a DPM and is not recommended in this case. In the same way, laying flagstones on a concrete base will create a similar effect.
- iii. Applying insulation to a wall may be acceptable where the existing wall finishes and features are of no significant historic value.
- iv. Insulation must be continued into recesses in the external wall, such as window and door openings and under lintels, to prevent the formation of cold bridges.
- v. In the case of solid floors, air movement behind the insulation is likely to be very low or non-existent. There may be fortuitous air leakage at skirtings, door and window openings but, as this is not always the case, it is important to ensure that external stonework and roof drainage is kept in good repair to minimise rain water penetration into walls.
- vi. A French drain and/or surface paving may be required to control ground water adjacent to external walls and to limit moisture transfer to the wall from the ground.

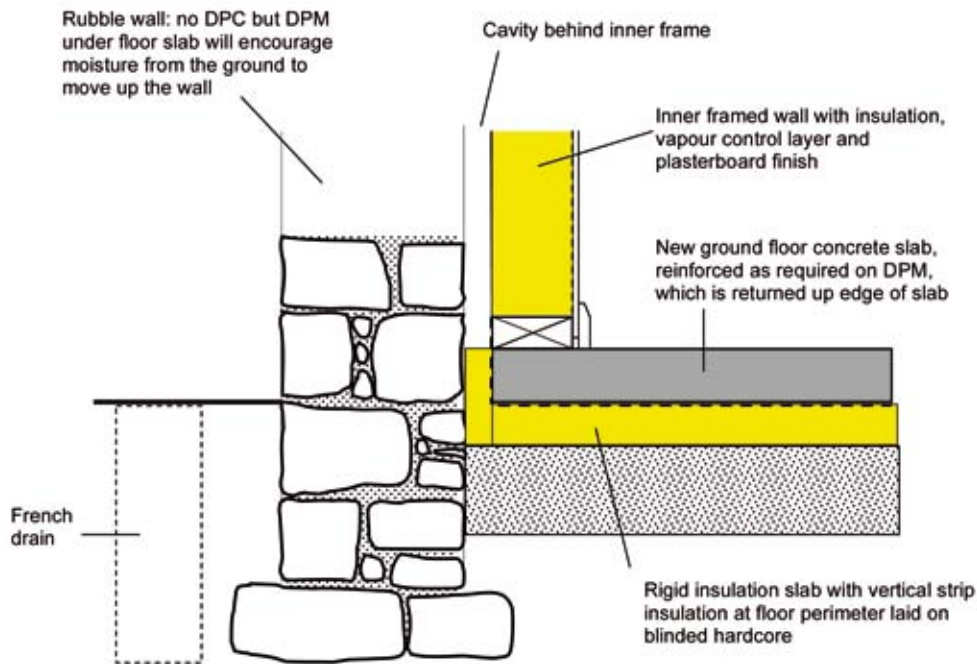

*Illus 6.2.1(b) Floor and wall insulation when existing wall and ground floor finishes are replaced.*

Notes associated with Illus 6.2.1(b).

- i. Notes associated with Illus 6.2.1(a) apply, with the exception of note (ii).
- ii. Insulation at the floor slab perimeter is required.
- iii. The DPM, positioned under the concrete slab, should be returned up the edges of the floor and lapped with a DPC dressed up behind any timber sole plates forming part of an inner-framed wall.

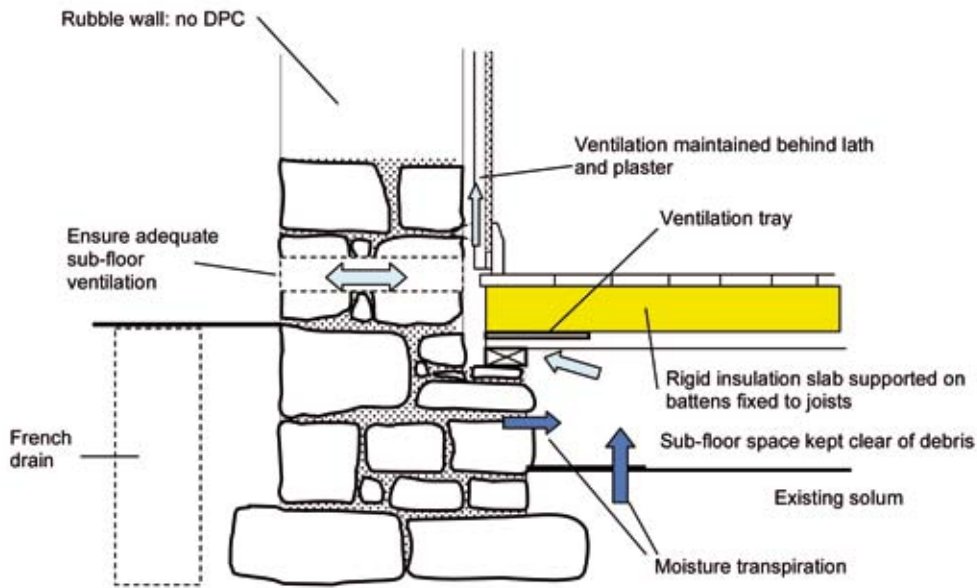

Illus 6.2.1(c) Insulation of suspended timber floor with all existing structure and finishes retained.

Notes associated with Illus 6.2.1(c).

- i. Insulation applied in this way is appropriate when access can be obtained to the sub-floor space.
- ii. Maintaining a flow of air in the sub-floor space and behind lath and plaster finishes on external walls is an important feature of the construction. Ensure that installation of the insulation does not obstruct free movement of air. This construction is not the most thermally efficient approach, but maintains an essential moisture balance within the construction.
- iii. Moisture from the wall and from the solum is able to transpire into the ventilated spaces.
- iv. Because insulation of the wall is not improved, energy efficiency gains can be achieved by the installation of heat-reflective films fixed behind radiators.

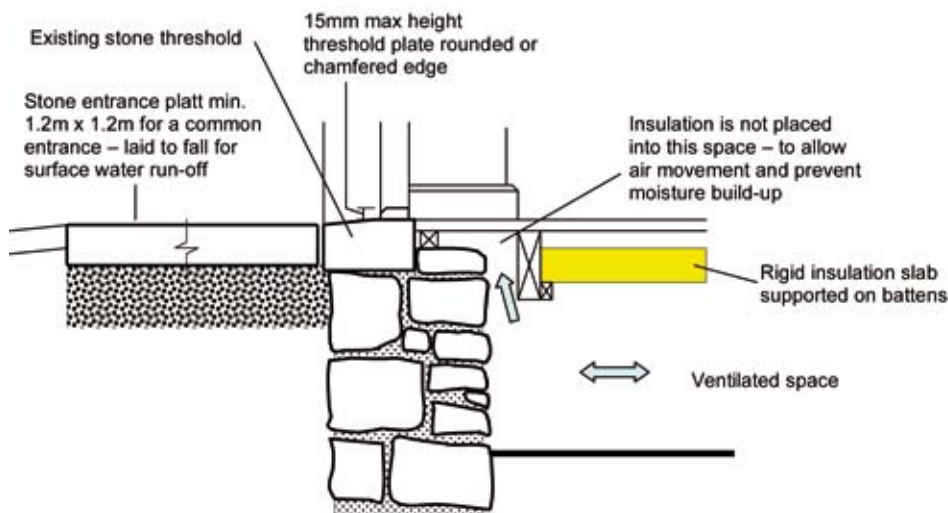

Illus 6.2.1(d) Suspended timber floor insulation at a common entrance with an accessible threshold (see also Standard 4.1.8 for thresholds).

Note associated with Illus 6.2.1(d)

It is recommended that insulation is not packed into the space below the floor at the threshold. This would prevent air movement in the void and raise the moisture content of adjacent timbers.



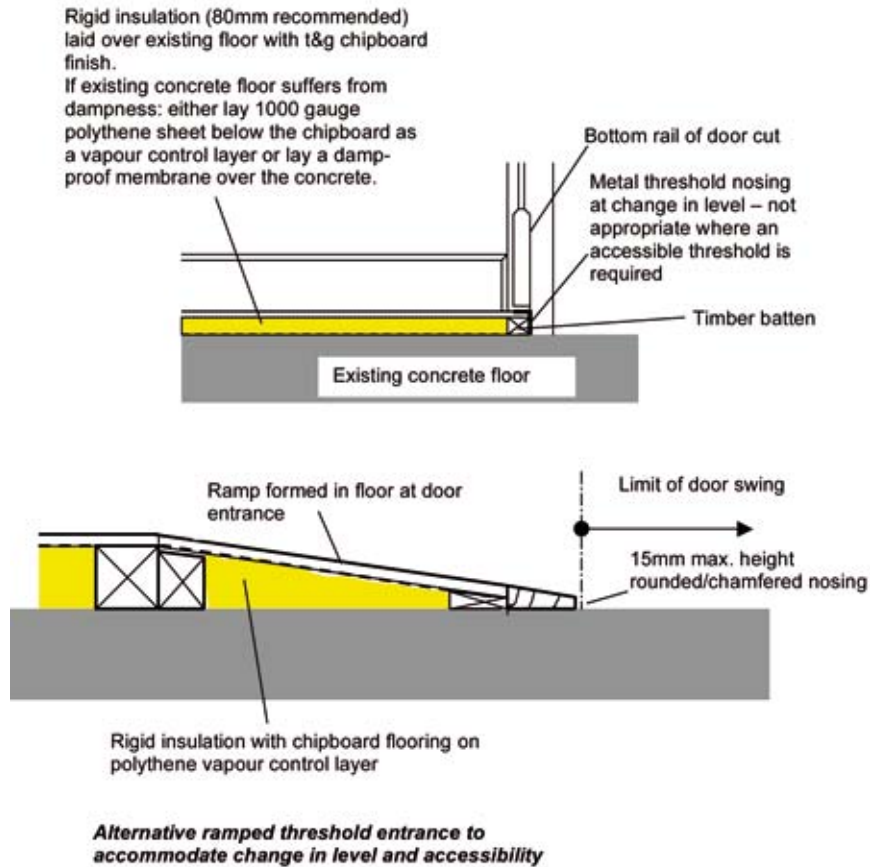

*Illus 6.2.1(e) Insulation applied to an existing concrete floor.*

Notes associated with Illus 6.2.1(e).

- i. Doors will have to be cut to accommodate the thickness of the applied floor finish. Skirtings will have to be removed and re-fixed, which may affect other wall finishes such as wood panelling.
- ii. A change in floor level at entrances may be difficult to accommodate.
- iii. Where a staircase rises from the floor, the alteration in the height of the bottom riser will create uneven rises and will be unacceptable without further major adjustments.
- iv. Leave a 10mm gap between the edge of the chipboard flooring and the room perimeter to accommodate thermal and moisture movement of the flooring (this will be covered by the skirting).
- v. If polystyrene insulation is used, ensure that any electrical cables do not come into contact with the polystyrene.

**Roofs**

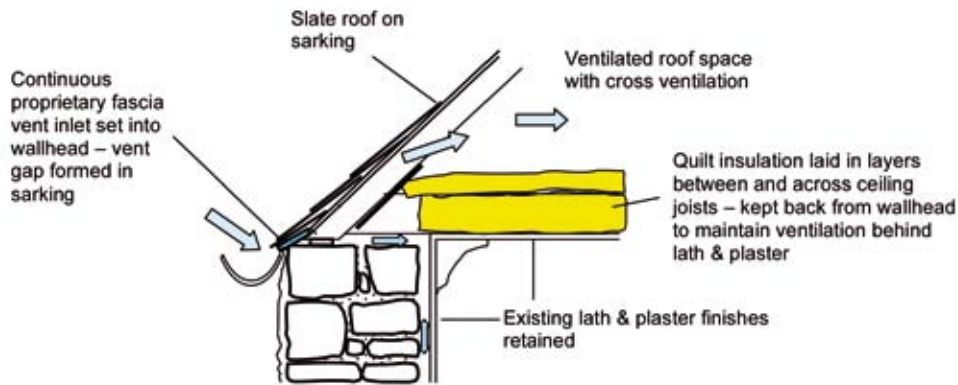

*Illus 6.2.2(a) Cold roof: Traditional wallhead detail with ceiling level insulation.*

Notes associated with Illus 6.2.2(a).

- i. Traditional roofs do not normally have built-in ventilation, but the nature of the construction is such that a degree of fortuitous air leakage is normal.
- ii. The quilt insulation is most effective when laid in two layers, with one layer laid between the ceiling joists/ties and a second layer laid across the joists/ties.
- iii. Roof space ventilation is essential. In this case a continuous proprietary vent inlet is built into the wallhead, and sarking is cut back to allow a free flow of air into the roof space. A ventilator of this type is least damaging to the character of the slated or tiled roof.

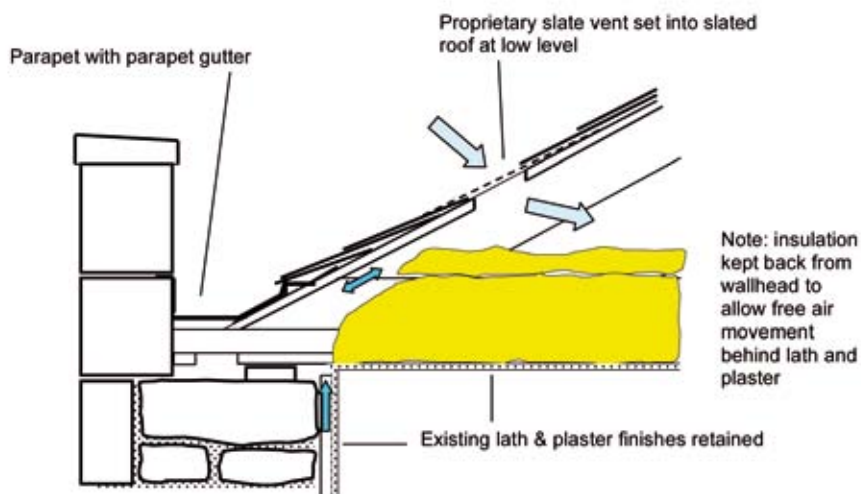

*Illus 6.2.2(b) Cold roof: Parapet wallhead detail with ceiling insulation.*

Notes associated with Illus 6.2.2(b).

- i. The raised parapet influences cross ventilation of this roof. Ventilators therefore have to be installed on the roof slope, which may affect the historic character of the slated or tiled roof.
- ii. Ventilators should be installed at as low a level as possible to prevent stagnant air pockets forming under the sarking, below vent level.
- iii. Ventilators should not be located directly opposite each other on opposite sides of the roof, to prevent the occurrence of a ‘wind-tunnel effect’.

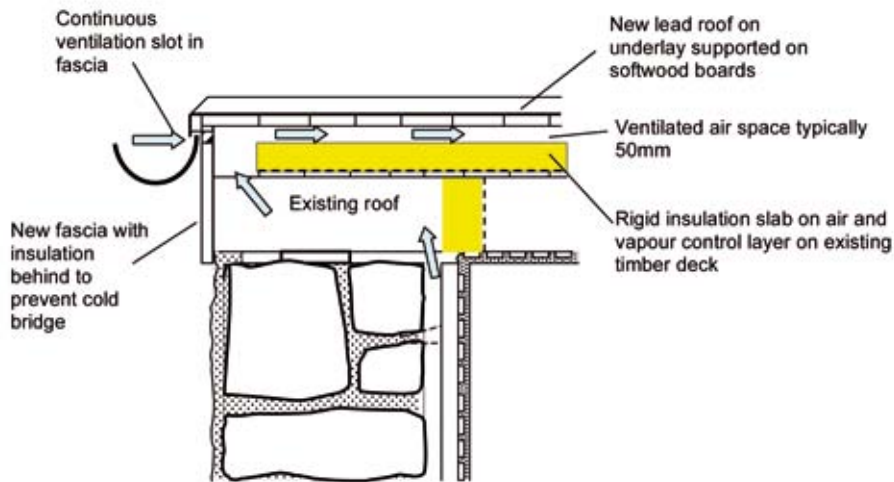

Illus 6.2.2(c) Flat roof: ventilated warm roof with lead covering.

Notes associated with Illus 6.2.2(c).

- i. In warm roof construction incorporating a sheet lead roof covering, ventilation below the boards supporting the lead is required to prevent underside lead corrosion (ULC).
- ii. The incorporation of insulation and a ventilation space above the insulation will mean that alterations will be required to the roof fascia to accommodate the increased depth of roof.

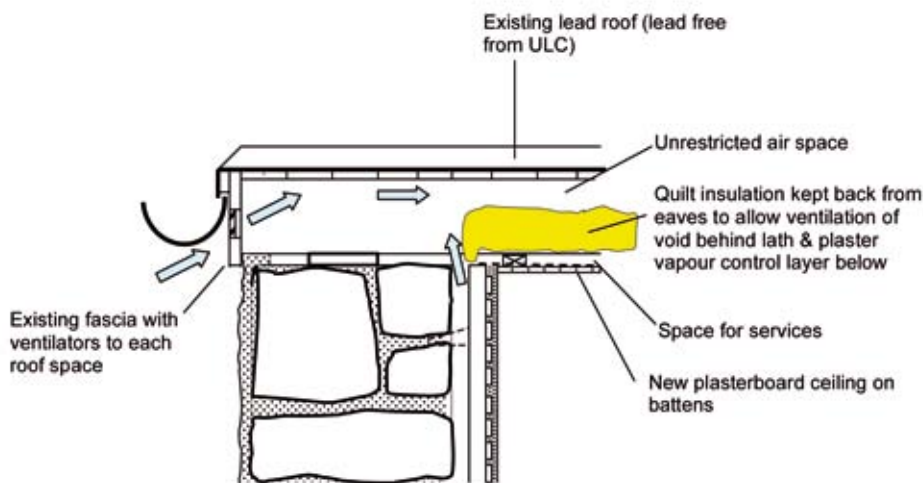

Illus 6.2.2(d) Flat roof: ventilated cold roof. Used where lead roof is retained and removal of existing ceiling is appropriate.

Notes associated with Illus 6.2.2(d).

- i. This form of insulated roof may be used when the existing lead is retained and when removal of the existing ceiling can be achieved without adversely affecting the historic character of the building.
- ii. All voids within the roof must be ventilated, which will require either a continuous vent at fascia or eaves soffit level, or individual fascia vents with ventilation between individual roof joists.

**Windows and doors**

As a rule, during the conversion process, traditional windows and doors in historic buildings should be retained, and repaired where appropriate. Window openings and frames are a significant factor in establishing the character of a building's elevation and should not be altered in their proportions or design. Where new openings have to be formed, the new openings and frames should match the proportions, materials and design on the existing windows. For further information on issues relating to windows, refer to Part I, Section 3.2.5.

In the case of a conversion, windows, doors and rooflights will form part of the insulation envelope. Although required to be 'improved to as close to the standards as is reasonably practicable', the guidance on compliance gives advice not only on whether it is necessary to upgrade but also different values depending on whether the existing building was heated or not. The values are also area weighted averages, so not all parts of an element such as windows has to meet the standard. Therefore, although the standard is to be met, the standard is applied to conversions in a very flexible way. Note that historic buildings have special guidance indicating some elements may not be suitable for upgrading at all.

In situations where unsuitable high-performance double-glazed windows have to be replaced, the advice set out in Part 1, Section 3.2.6 should be followed. Where this is the case, compensatory measures will be required elsewhere because, to comply with the standard, envelope insulation must be no worse than before the conversion.

The following steps to improve the thermal performance of windows and doors can be considered:

- a) Air infiltration through old windows and doors is often significant and modern draught proofing systems can be very effective in reducing air leakage and heat loss. For advice on upgrading the performance of timber sash and case windows, refer to the Historic Scotland Guide for Practitioners: *Conservation of timber sash and case windows* (2002). Draught strips for doors and windows are covered by BS 7386. However, care is required to ensure that adequate ventilation is maintained to remove moisture and pollutants from internal spaces and to achieve the minimum number of air changes per hour (ach).
- b) Secondary glazing may be acceptable if its design and construction are unobtrusive. However, such installations may not be suitable where internal window sills or window reveals have insufficient width, where shutters are present or where windows are oddly-shaped.
- c) Night-time heat loss may be reduced by bringing back into use traditional shutters, or replacing shutters that have been lost. Shutters can be draught stripped to improve further their performance.
- d) Insulated and/or reflective blinds may be used where their installation can be accommodated without seriously affecting the character of the window.

**6.2.5 Related standards**

Other related standards are:

- Standard 3.13 Heating
- Standard 3.14 Ventilation
- Standard 3.15 Condensation
- Standard 6.1 Energy Policy
- Standard 6.3 Heating systems and
- Standard 6.6 Mechanical ventilation and air conditioning

## 6.3 Heating systems

### Standard 6.3

In order to comply with standard 6.1 every *building* must be designed and *constructed* in such a way that the heating and hot water service systems are designed, installed, and capable of being controlled to achieve optimum energy efficiency, having regard to the thermal transfer of the *insulation envelope*.

#### Limitation

This standard does not apply to:

- (a) *buildings* which do not use fuel or power for controlling the temperature of the internal environment;
- (b) *buildings*, or parts of a *building*, which will not be heated, other than heating provided for the purpose of frost protection;
- (c) heating systems provided for the purpose of frost protection; or
- (d) individual, solid-fuel stoves or open-fires, gas or electric fires or room heaters (excluding electric storage and panel heaters) provided in *domestic buildings*.

### 6.3.1 Type of standard

#### **Reasonably practicable standard**

Every *conversion*, to which these regulations apply, must be improved to as close to the requirement of the standard as is *reasonably practicable*, and in no case be worse than before the *conversion*.

### 6.3.2 Commentary

Refer to Commentary in Section 6.1.2, which provides an overview of the approach to this standard. This standard is concerned with the design, installation and control of heating and hot water systems and, as such, is primarily designed for new building work and consequently new buildings. However, the use of energy-efficient heating and hot water systems is an essential feature of a holistic approach to the conversion of a traditional building, where deficiencies in the insulating envelope can be partially offset by energy savings in the heating and hot water systems. It is important to demonstrate that everything else that reasonably could be done to improve the energy performance of the building has been considered.

The guidance within the standards for domestic systems and the table within the non-domestic system guidance to Standard 6.3 (which indicates the carbon emission factors for natural gas and other fuels) have the effect of setting a preference order for different types of fuel. Everything else being equal, it can be seen by inspection that the forms of heating fuel preferred on purely carbon dioxide emissions grounds would be:

- biogas (eg methane generated from decay of organic material) and biomass (eg wood chips/pellets from sustainable sources),
- mains natural gas,
- liquid petroleum gas,
- oil,
- coal,
- mains electricity.

To this could be added any form of energy from completely renewable sources such as electricity generated by wind power or photovoltaic cells, or water heating by solar panels.

The exclusive use of biogas, biomass or energy from renewables alleviates all concerns on carbon intensity because the net carbon emissions of these energy sources is zero. It would be unusual however, to find that it was possible

to rely exclusively on these. How practical and how economically viable it is to utilise these energy sources, and to what extent they should be used in a development, depends very much on the particular circumstances.

Controls for heating and hot water systems are unlikely to have a direct, significant impact on historic fabric, provided they are discreet in both design and location. In assessing the energy needs of the building as converted, the heating regime of each part of the building should be determined. For example, the heating requirements of storage areas such as basements will be different from living rooms and office accommodation. For buildings other than small dwellings it is normal to fit zone controls that will maximise the energy efficiency of the installation. This, in turn, may mean that smaller diameter pipework can be used, which can result in a reduction of the impact on historic fabric through the use of smaller holes in walls and fixings.

The physical installation or replacement of services must be carefully planned to prevent unnecessary damage to historic fabric. It is also essential to recognise the relatively short service life (in relation to historic buildings) of service elements, and therefore the need for future upgrading and replacement, which may damage fabric if the principles of reversibility and minimum intervention are not recognised in the design of installations. This means that in the design of the systems great care must be taken to ensure that pipe runs, for example, do not cause direct and indirect damage to fabric and that holes, chases and fixings are designed in a way that is least damaging to the building.

In the case of hot water systems, the opportunity should be taken to simplify and reduce the lengths of pipe runs, provide effective controls and enhance the insulation of pipes to improve the overall energy efficiency of the conversion. In some situations it may be desirable to install more local water heaters to reduce the need for damaging pipework installations.

From May 2007, draft amended standard 6.3 is:

Every *building* must be designed and *constructed* in such a way that the heating and hot water service systems are designed, installed, and capable of being controlled to achieve optimum energy efficiency.

Limitation

This standard does not apply to:

- a) *buildings* which do not use fuel or power for controlling the temperature of the internal environment;
- b) heating provided solely for the purpose of frost protection; or
- c) individual, solid-fuel stoves or open-fires, gas or electric fires or room heaters (excluding electric storage and panel heaters) provided as secondary heating in domestic buildings).

This standard is simplified, but the guidance remains applicable.

**6.3.3 Issues to be considered**

Issue	Risks to historic/traditional buildings
1. Compensating for reduced envelope insulation	<ul style="list-style-type: none"> <li>• Increased size/capacity of heating systems may be more intrusive and affect historic character. However, efficient, modern installations are likely to be more compact than existing systems that are being replaced.</li> <li>• Increased number of heat emitters of larger size (as a result of only limited improvements to the envelope insulation).</li> <li>• In replacing existing heat emitters, for example cast-iron radiators, with more efficient modern appliances, there may be a loss of part of the history of the building.</li> <li>• Some alternative energy solutions may affect the character of the building, for example, solar panels on roofs.</li> </ul>
2. Zoning of buildings	<ul style="list-style-type: none"> <li>• Only becomes a risk if existing spaces are altered to meet zoning requirements.</li> </ul>
3. Location of controls	<ul style="list-style-type: none"> <li>• Require to be carefully sited to avoid adversely affecting character of spaces.</li> </ul>
4. Condensing boiler flues	<ul style="list-style-type: none"> <li>• Condensation plumes can damage historic fabric.</li> </ul>

### 6.3.4 Recommendations to meet the standard

As a rule, the requirements of this standard may be achieved without significant impact on historic fabric or character. The following points, however, should be considered:

- a) Electrical heating systems are cheap to install and maintain, but running costs and environmental impact are higher than for other fuels. For this reason, electrical systems for space and hot water heating are discouraged. Energy Saving Trust Good Practice Guide 192 (2003), which goes some way beyond minimum building regulation standards, recommends that *'buildings with electrical heating will need to have better insulation levels. Only small sheltered dwellings... are likely to meet the relevant minimum CI rating given in the Good and Best Practice standards using the maximum U-values given in the standards. For buildings other than dwellings where the CI targets do not apply, electric heating should only be used if the fabric U-values are no worse than those given in the Best Practice standard.'* The main advantage of electrical systems is that, in the case of historic buildings, their installation will be less destructive to building fabric and, in some situations, may be the only viable system.
- b) When designing for heating plant and controls for larger buildings, or groups of buildings, consideration should be given to the user patterns and periods of occupation. If a large single or centralised plant is used the plant may be operating inefficiently for long periods of time. An alternative approach may be to use hybrid or multiple boiler systems, which could be more efficient. In commercial-scale buildings it may be cost effective to separate the domestic hot water heating from space heating. However, the particular layout and characteristics of a traditional building may influence the choice of heating system as, for example, a multiple boiler system may not be able to be accommodated within the available spaces.
- c) Zone controls should be properly integrated to take into account the influence of solar gain and user patterns in the building. In zoning the building and its controls, the different aspects of the building and any shading effects should be taken into account. Zone controls will limit overheating effects in well-insulated buildings and will produce energy savings in those historic buildings where improvements to envelope insulation are, of necessity, limited.
- d) Improvements in the condensing performance of space-heating boilers can be secured by sizing the heating system radiators and pipework on a greater than normal water temperature difference between the flow to return pipes. The conventional temperature difference in the industry is 10°C or 11°C. By increasing this to 20°C, the return water temperature to the boiler is reduced and so the condensing performance further enhanced. This means that the size of the system pipework can be reduced in many areas. In historic buildings the advantage of this is that it can ease problems associated with pipework distribution, especially the depth of notches in joists. The disadvantage of this is that radiator sizes must increase somewhat to give the same heat output. Generally the order of increase over a radiator sized on conventional flow and return temperatures is 20 – 25% in nominal output.
- e) There are some important issues relating to the flues from condensing boilers, which must be considered when locating the terminals. The normal requirements for terminals under the standards are set out in Sections 3.19 and 3.20, but these provisions only address safe discharge of combustion gases. Condensing boiler flues produce a very prominent plume of condensation, particularly in cold weather. These plumes can be damaging to the historic fabric if they result in parts of the building being almost permanently wet. They are mildly acidic and so the reaction with materials (such as lime mortar) must also be considered. For example copper is known to corrode rapidly when exposed to this condensate. Then there are the aesthetic implications of these plumes, which can appear intrusive, and can cause a nuisance to those located in such a way that the plume is particularly obvious.

In larger buildings with a relatively large central boiler plant, the flues will normally be vertical with outlets at roof level. In these instances the plumbing is usually less problematic.

In smaller buildings, or buildings divided into a number of smaller individual units, the associated smaller boilers will often have wall terminals and the location of these is very important. This is of special concern in flats, where the plume from a wall terminal located in the flat below can become an almost permanent feature passing the window of a flat above (whilst still complying with all of the requirements for safe location of the terminal). One possible solution to this problem is to utilise a proprietary vertical flue system which gathers the individual boiler flues into a combined stack which then discharges at roof level. This creates other practical problems with aligning boiler locations on different floors and so on. This is often problematic in historic building conversions, but may be possible in certain buildings. The penetration of walls with

individual flues is, however, also destructive to the character and fabric of historic buildings.

- f) Alternative energy solutions, of which there are a number of possibilities, may be used to reduce carbon dioxide emissions and, while not directly related to this standard, could be appropriate for some historic building conversions. Perhaps the most viable solution is the use of biomass and bio-gas-burning boilers. This is not a 'low-tech' solution: it requires specialist design and installation. At 2006 energy costs, wind power and photovoltaic cells are rarely cost effective unless the capital cost of the equipment is heavily subsidised. Also to be considered, in the case of listed buildings, is that listed building consent may be required for such installations. Refer to Section 4.6.2 of this guide for further information on alternative energy solutions.
- g) There may be a desire to eliminate the use of open-flued appliances by sealing up fireplace openings and replacing them with modern, energy efficient balanced-flue appliances. While this will be appropriate in some situations, it is possible that the effects of such installations will be damaging to historic fabric. The risks associated with such a change may be from damage caused by forming the hole for the flue, the potential disturbance within a rubble-filled wall, the aesthetic damage of the external flue terminal and excessive drying of an earth wall where the flue passes through the wall (i.e. disturbing the moisture balance within the wall).

### 6.3.5 Related standards

Other related standards are:

- Standard 3.19 Combustion appliances; relationship to combustible materials,
- Standard 3.20, Combustion appliances: removal of products of combustion,
- Standard 6.1 Energy policy,
- Standard 6.2 Envelope insulation,
- Standard 6.6 Mechanical ventilation and air conditioning.

## 6.4 Insulation of pipes ducts and vessels

### Standard 6.4

In order to comply with standard 6.1 every *building* must be designed and *constructed* in such a way that temperature loss from heated *pipes, ducts* and *vessels*, and temperature gain to cooled *pipes* and *ducts*, is resisted.

#### Limitation

This standard does not apply to:

- (a) *buildings* which do not use fuel or power for heating or cooling either the internal environment or water services;
- (b) *buildings*, or parts of a *building*, which will not be heated, other than heating provided for the purpose of frost protection;
- (c) *pipes, ducts* or *vessels* that form part of an isolated industrial or commercial process; or
- (d) cooled *pipes* or *ducts* in *domestic buildings*.

### 6.4.1 Type of standard

#### Reasonably practicable standard

Every *conversion*, to which these regulations apply, must be improved to as close to the requirement of the standard as is *reasonably practicable*, and in no case be worse than before the *conversion*.



### 6.4.2 Commentary

It will normally be the case in a conversion of a traditional building that, where the building is to be heated, upgrading of the heating and hot water system will be necessary. As a result, the insulation of all heating pipes and ducts and hot water pipes and vessels will require to be insulated to as high a degree as is possible, within the constraints of the historic fabric. However, it is recognised that complete insulation of all pipes and ducts will not always be possible where services penetrate walls, pass through or around other structural elements and where minimal damage to surface finishes is required. The planning of service routes to achieve the most efficient performance, while respecting historic fabric, needs to be carefully carried out at design stage to ensure that buildability is achieved. The routing of pipes and ducts should not be left to the discretion of site operatives, who may not have the necessary understanding of the needs of historic buildings.

From May 2007:

The draft amended Standard 6.4 removes the link to Standard 6.1, so the standard remains applicable to *conversions*, as does the guidance given.

### 6.4.3 Issues to be considered

Issue	Risks to historic/traditional buildings
Routing of pipes and ducts.	The routing and insulation of new pipework may be disruptive to fabric in the following ways: <ul style="list-style-type: none"> <li>• Covering up historic features or details,</li> <li>• Causing direct damage during installation or subsequent maintenance,</li> <li>• Inducing pattern staining of plaster finishes (improved pipework insulation will reduce this effect),</li> <li>• Increasing the diameter of pipework, by adding insulation, which may make it more intrusive and may create dirt traps when pipes are close to the surface.</li> </ul>

### 6.4.4 Recommendations to meet the standard

Insulating pipes and ducts is one of the key energy conservation options available in a historic building conversion. Where improvements to envelope insulation may have to be limited, it will be essential to provide energy reduction measures elsewhere as a trade-off when this can be achieved without loss of historic character, including the insulation of pipes and ducts.

In historic buildings the key concern in complying with the requirements of this standard is that insulation of pipework increases the diameter of the pipes and so exacerbates the problems with routing of the services through the building. The best way to minimise the impact of the insulation is to select high-performance insulation material that is manufactured in convenient pre-formed sections. High performing materials have low thermal conductivities and so the same insulation value can be obtained using thinner layers. The guidance to the standard is worded pragmatically and it is acknowledged that where pipes and ducts pass through parts of the building fabric such as walls or floor joists the insulation need not be carried through. Using the thinnest insulation layer that will meet the standards will allow notches in floor joists to be somewhat shallower than they otherwise might have been.

### 6.4.5 Related standards

Other related standards are:

- Standard 3.13 Heating
- Standard 6.1 Energy Policy
- Standard 6.2 Envelope insulation,
- Standard 6.3 Heating systems and
- Standard 6.6 Mechanical ventilation and air conditioning.

## 6.5 Artificial and display lighting

### Standard 6.5

In order to comply with standard 6.1 every *building* must be designed and *constructed* in such a way that artificial or display lighting must operate and be capable of being controlled to achieve optimum energy efficiency.

#### Limitation

This standard does not apply to:

- (a) process and emergency lighting components of a *building*; or
- (b) *domestic buildings*.

### 6.5.1 Type of standard

#### **Reasonably practicable standard**

Every *conversion*, to which these regulations apply, must be improved to as close to the requirement of the standard as is *reasonably practicable*, and in no case be worse than before the *conversion*.

### 6.5.2 Commentary

Given the possibility that improvements to envelope insulation are likely to be limited, energy saving measures must be sought elsewhere. While this standard is applicable to only non-domestic buildings, artificial lighting can account for a significant proportion of the electricity used in both domestic and non-domestic buildings and, in the case of some non-domestic buildings this can also apply to lighting used for display purposes. The use of energy-efficient lighting for domestic buildings, although not a requirement of this standard, must be considered along with other energy reduction measures.

By considering the total lighting needs of a building, including natural light, appropriate lighting design can reduce energy requirements and costs. In addition, the heat gain in well-insulated buildings from artificial lighting can be a significant proportion of the total heat gain in the building, leading to the need for air conditioning. Good energy efficient design of lighting can reduce the need for air conditioning, which, as well as creating an energy demand, can be both difficult to install and destructive to historic buildings.

Most historic buildings were constructed before electric lighting became common in buildings, therefore any electric lighting that is present is not likely to be contemporary with the building and fittings, and wiring will have been renewed several times since the original installation. However, the design of energy-efficient lighting must recognise the impact that a modern system could have on the character of a traditional building, be designed in a way that minimises the aesthetic impact and, as far as possible, be compatible with its character.

There may be temptation to concentrate on the aesthetics of lighting design and select 'traditional' incandescent tungsten filament lighting (the oldest form of electric lighting) in the belief that these are more compatible with historic character. This, however, is probably more a matter of personal taste rather than a true reflection of historic accuracy. Modern compact fluorescent lamps (CFLs), and the even more efficient fluorescent tube lighting, will normally not be readily accommodated by existing tungsten light fittings. It is important to consider the character of each space and to design an installation that achieves the correct balance between aesthetic and efficiency criteria.

From May 2007, draft amended standard 6.5 is:

Every *building* must be designed and *constructed* in such a way that artificial or display lighting are designed, installed and capable of being controlled to achieve optimum energy efficiency.

#### Limitation

This standard does not apply to:

- a) process and emergency lighting components of a *building*; or
- b) alterations in *domestic buildings*.

This standard will now require some energy efficient lighting in dwellings as well as non-domestic buildings. The guidance given remains applicable.

**6.5.3 Issues to be considered**

Issue	Risks to historic/traditional buildings
Detrimental effect of historic character	<ul style="list-style-type: none"> <li>• Good design and selection of lamps and fittings should mean that their impact on character is minimal (refer to notes in 6.5.2 above), with little risk to historic buildings.</li> </ul>

**6.5.4 Recommendations to meet the standard**

As each building is unique, the design of the lighting should recognise the historic character of the individual spaces. However, the use of energy efficiency lighting and controls, as identified in Standard 6.5, will be an important feature of improved energy efficiency in the conversion and can, in most situations, be implemented in full.

When considering an energy efficient lighting installation the following key areas must be considered (for further guidance refer to Good Practice Guide 192):

- the use of daylighting to reduce artificial lighting needs,
- lighting design that balances the functional needs of the user with the aesthetics of the space,
- luminaire and lamp choice and
- lighting controls to ensure that artificial lighting is used only when it is required.

There are sometimes aesthetic concerns over the use of luminaires that use efficient light sources such as compact or linear fluorescent lamps in historic buildings. In conversions to commercial uses such as offices it is usually possible to design new lighting schemes using efficient luminaires which are clearly modern, but not intrusive or incongruous.



*Illus 6.5.1 Discreet, energy-efficient lighting supplements natural light to a gallery in a converted historic building (Photo: courtesy of iGuzzini).*

**6.5.5 Related standards**

Other related standards are:

- Standard 3.13 Heating
- Standard 6.1 Energy Policy
- Standard 6.2 Envelope insulation
- Standard 6.3 Heating systems and
- Standard 6.6 Mechanical ventilation and air conditioning.

## 6.6 Mechanical ventilation and air conditioning

### Standard 6.6

In order to comply with standard 6.1 every *building* must be designed and *constructed* in such a way that the form and fabric of the *building* minimises the use of mechanical ventilating or cooling systems for cooling purposes, and the ventilating and cooling systems are designed, installed, and capable of being controlled to achieve optimum energy efficiency.

Limitation:

This standard does not apply to:

- (a) *domestic buildings*; or
- (b) *buildings* which do not use fuel or power for ventilating or cooling the internal environment.

### 6.6.1 Type of standard

#### ***Reasonably practicable standard***

Every *conversion*, to which these regulations apply, must be improved to as close to the requirement of the standard as is *reasonably practicable*, and in no case be worse than before the *conversion*.

### 6.6.2 Commentary

For most Scottish historic buildings, compliance with this standard should not present significant difficulties, or pose unmanageable risks to historic character. The aim of the standard is to reduce the installed capacity of mechanical ventilation and cooling equipment. As traditional buildings normally have high thermal mass, high levels of natural ventilation and relatively small areas of external glazing, they have a slow thermal response to solar gains. Thus the thermal mass of the fabric acts as an effective control and reduces the need for excessive air conditioning and mechanical ventilation (ACMV) installed capacity, which should be designed accordingly. Care, however, has to be exercised in the case of conversions that retain only the external walls, which are then insulated to current standards. While solar gains may still remain modest, the highly insulated nature of the fabric when associated with large thermal gains from occupants and equipment, such as in offices, call centres and the like, will increase the need for mechanical ventilation and cooling.

However, the installation of ACMV within a traditional building will generally mean very careful handling of the design of the installation to minimise the impact of features such as extract vents and roof-located plant on historic character. New ACMV systems must be able to be installed with minimum damage to existing fabric and should be aesthetically compatible with the spaces in which they are located. The system should be sized to work within the physical constraints of the building as oversized plant in small spaces are difficult to install and maintain, and there is a risk of damage to fabric during these operations.

The use of through-wall air conditioning units for individual spaces is visually disfiguring, destroys historic fabric and should be avoided. In addition, condensation run-off from these units can cause further damage to historic materials. Condensation can also be a problem where humidification is required, for example in museums, as condensation can occur on single glazing, and interstitial condensation can be encouraged.

Because ACMV systems will tend to change the natural moisture balance within the building and its fabric, it is advisable to set up a system of regular monitoring to ensure that deterioration of historic fabric is not accelerated. This may be either a manual system or an automatic system for complex buildings. Whenever possible, natural ventilation systems are the preferred option.

Where a traditional building already has an ACMV system, the opportunity should be taken to assess the form and fabric of the building from the viewpoint of both energy efficiency and historic character. The condition, energy efficiency, capacity of, and controls for, the system should be evaluated and, if necessary, a new system installed that is more energy efficient. Plant, ducts and other equipment may be reduced in scale, which should minimise the impact of the installation on historic fabric. It may even allow for the restoration of previously hidden or damaged fabric.

From May 2007, draft amended standard 6.6 is:

Every *building* must be designed and *constructed* in such a way that:

- a) the form and fabric of the building minimise the use of mechanical ventilating or air conditioning systems for cooling purposes; and
- b) in *non-domestic buildings* the ventilating and cooling systems are designed, installed, and capable of being controlled to achieve optimum energy efficiency.

Limitation

This standard does not apply to *buildings* which do not use fuel or power for ventilating or cooling the internal environment.

This standard has been extended to dwellings as it is intended to discourage the use of air conditioning. The guidance however remains applicable.

**6.6.3 Issues to be considered**

Issue	Risks to historic/traditional buildings
1. Location and installation of plant, ducts and extractors	<ul style="list-style-type: none"> <li>• Oversized plant in small spaces may damage fabric during installation and maintenance.</li> <li>• Installation may damage historic finishes or obscure historic features.</li> <li>• Vents in external wall are visually disfiguring and destroy historic fabric.</li> <li>• Accommodation of ducts can be very damaging by visual intrusion into spaces or by the use of suspended ceilings.</li> <li>• Systems operate more efficiently when the fabric is sealed, but sealing of traditional windows and other means of preventing infiltration can be damaging to historic fabric.</li> <li>• Condensers, stacks, vents or other equipment can be damaging to character if poorly sited on roofs or at other significant locations on the site.</li> <li>• Plant may overload the existing structure, and strengthening work must be carefully planned and executed.</li> <li>• Vibration from the plant must be dampened to avoid damage to fabric.</li> </ul>
2. Humidification	<ul style="list-style-type: none"> <li>• Humidification, if used, can cause condensation (surface and interstitial) that is damaging to fabric.</li> </ul>

**6.6.4 Recommendations to meet the standard**

Because this standard is concerned with reducing the excessive installed capacity of mechanical ventilation and cooling systems, and due to the nature and construction of historic buildings, it is probable that the standard can be met without too much difficulty. However, the successful installation of any new ACMV system into a traditional building can present significant challenges. There are situations that require a highly controlled climate – such as in museums and for operations housing large, complex computing equipment generating large amounts of heat – where both the visual and physical damage to historic character can be considerable.

In converting a traditional building careful consideration should be given to minimising the potential for over heating of the spaces, which might result in the need for mechanical ventilation or air conditioning to reduce unacceptably high temperatures. This is primarily a problem in non-domestic buildings, to which this standard mainly relates. While being good practice, and a requirement of the technical standards, it should also be appreciated that the installation of mechanical ventilation or air conditioning usually requires significant interventions with historic fabric, and so they are to be avoided whenever possible for this reason.

A major contributor to overheating is solar gain through windows. Often in conversion work the size and orientation of windows is fixed. However, while space planning the converted interiors, consideration should be given to the potential for over-heating due to large south-to-west-facing windows. It may be possible to arrange circulation spaces and the like such that they are next to the southern or western elevations, so that higher internal temperatures are less concerning than for the normally occupied areas.

Solar shading should also be considered. External shading designed to block direct sunlight at high sun angles (in summer), but admit sunlight at lower angles (in winter) are most effective, but incorporating such shading devices

into a historic façade is rarely possible. The next most effective methods for shading are blinds and internal ‘light shelves’. Light shelves are reflective horizontal panels, typically positioned between one quarter and one third of the way from the top of the window and projecting into the room by between 600mm and 1200mm. These shelves provide shading to much of the building interior while reflecting some light upwards to the ceiling. They are a prominent feature in any room however, and the effect of these on the enjoyment of any historic building interior would need to be assessed.

A further major contributor to heat gains is artificial lighting and equipment (eg office machines) within the space. Selecting the most energy efficient light sources and other possible equipment can reduce the heat output from these. Also, being realistic when planning the occupancy of spaces is essential so that attempts are not made to cram too many occupants (and their heat-producing equipment) into rooms.

There are sometimes aesthetic concerns over the use of luminaires that use efficient light sources, such as compact or linear fluorescent lamps, in historic buildings. In a domestic context this concern is sometimes justified, but in historic building conversions to commercial uses, such as offices, it is usually possible to design new lighting schemes using efficient luminaires that are clearly modern, but not intrusive or incongruous.

If, after doing everything practicable to limit the heat gains, it is still thought that ventilation is required, the first option that should be considered is maximising natural ventilation opportunities. Ensuring that as much as possible of the area of each window can be opened is an obvious first step, although in historic buildings this will often be determined by existing window configurations. The practicality of using openable windows also depends upon the location of the building and the immediate external environment. In noisy and/or polluted urban areas, for example, it may not be possible simply to open windows.

If openable windows alone are insufficient for one reason or another then other forms of natural ventilation can be considered. Generally these will rely on creating other ventilation openings in the building, and ducting air from these openings into the spaces. These ventilation openings will often be at roof level to avoid pollution, noise, and to minimise interference with the historic fabric. These installations may work on a purely ‘passive’ basis, relying upon the natural forces created by wind movements and temperature differences to draw fresh air into the building and then up an exhaust stack to discharge at roof level. For further information on ventilation systems, refer to Part II of this guide, Standard 3.14 Ventilation. If there are periods during which these natural forces are not adequate to generate the necessary air movement, fans can be installed at the head of the exhaust stack to draw the air through the system. This is one type of what can be termed a ‘mixed mode’ system. Mixed mode systems utilise comparatively low fan power, and then only when fan assistance is required, and so can assist in achieving the requirements under this section which relate to the efficiency of mechanical ventilation systems.

Passive or mixed mode ventilation systems require complex calculations and usually dynamic thermal modelling to ensure that they will work correctly, and so suitably qualified engineers would be required to prepare the designs.

Where the installation of an ACMV system is likely to cause serious disruption to a traditional building, the planned conversion to the new use must be questioned. However, should an ACMV system be necessary, the design of the system will involve a compromise between conflicting requirements. The design must be matched to the physical constraints and historic character of the building. ***It is therefore essential that, to achieve a balance between the conservation needs of the building and an energy-efficient ACMV system, specialist advice is sought from an ACMV engineer who has knowledge and experience of working with historic buildings.***

It is also essential to recognise that ACMV systems have a relatively short life and must be designed with planned obsolescence in mind. Future removal or replacement must be able to be carried out without loss of historic fabric.

#### **6.6.5 Related standards**

Other related standards are:

- Standard 3.13 Heating
- Standard 3.14 Ventilation
- Standard 3.16 Natural lighting
- Standard 6.1 Energy policy
- Standard 6.2 Envelope insulation
- Standard 6.3 Heating systems
- Standard 6.5 Artificial and display lighting.

**Draft amended standard 6.10 and new Regulation 17**

From May 2007 there is a further draft standard that applies to conversions.

**Standard 6.10**

6.10 Every *building* must be designed and *constructed* in such a way that each part of a *building* designed for different occupation is fitted with fuel consumption meters.

## Limitation

This standard does not apply to:

- a) domestic buildings;
- b) communal areas of buildings in different occupation;
- c) district or block heating systems where each part of the building designed for different occupation is fitted with heat meters; or
- d) heating fired by solid fuel or biomass.

Unlike the other standards in Section 6, conversions are required to meet this standard in full.

In addition, a further regulation is introduced to take effect only when, and to the extent that, Scottish Ministers direct. The intention is to introduce this requirement in stages, applying to the largest first. Few historic buildings are expected to fall into the likely categories of control.

**Regulation 17**

## Continuing requirements

1. Subject to paragraph (2), the owners of *buildings* shall ensure that:

- a) Every air-conditioning system within a *building* is inspected at regular intervals; and
- b) Appropriate advice is given to users of the *buildings* on reducing energy consumption of such an air conditioning system.

2. This regulation shall not apply to:

- a) Air conditioning systems with a total effective output rating of less than 12kW; or
- b) Air conditioning systems solely for processes within a *building*.

3. In terms of section 2 of the Building (Scotland) Act 2003 the provisions of paragraph (1) are designated provision in respect of which there is a continuing requirement imposed upon owners of the *buildings*.

# BIBLIOGRAPHY

- Allwinkle, Bell, Franklin, Hibbard, McQue, Marchant, Marshall, Newsom, Todd and Wren 1997, Technical Advice Note 11, *Fire Protection Measures in Scottish Historic Buildings*, Historic Scotland, Edinburgh.
- BRE Digest 208, *Increasing the fire resistance of existing timber floors*, Building Research Establishment.
- BRE Digest 398, *Continuous mechanical ventilation in dwellings: design, installation and operation*. Building Research Establishment.
- British Standards Institution, BS EN 811: 1998 *Safety rules for the construction and installation of lifts. Electric lifts*. BSI, London.
- British Standards Institution, BS EN 812: 1998 *Safety rules for the construction and installation of lifts. Hydraulic lifts*. BSI, London.
- British Standards Institution, BS 750: 1984 *Specification for underground fire hydrants and surface box frames and covers*. BSI, London.
- British Standards Institution, BS EN 1856-1: 2003, *Chimneys. Requirements for metal chimneys. System chimney products*, BSI, London.
- British Standards Institution, BS EN 1856-2: 2004, *Chimneys. Requirements for metal chimneys. Metal liners and connecting flue pipes*, BSI London.
- British Standards Institution, BS 3251: 1976 (1993) *Specification. Indicator plates for fire hydrants and emergency water supplies*. BSI, London.
- British Standards Institution, BS 5250: 2002 *Code of Practice for the Control of Condensation in Buildings*, BSI, London.
- British Standards Institution, BS 5266 1(2005): *Emergency Lighting, Code of Practice for emergency lighting of premises other than private domestic premises, cinemas and certain other premises used for entertainment, Part 7 (1999): Lighting applications – Emergency lighting* (also known as BS EN 1838:1999). BSI, London.
- British Standards Institution BS 5306-1: 1976, *Fire Extinguishing installations and equipment on premises: Hydrant systems, hose reels and foam inlets*. BSI, London.
- British Standards Institution BS 5306-2: 1990, *Fire extinguishing installations and equipment on premises Part 2: Specification for sprinkler systems*. BSI, London.
- British Standards Institution 1999, Code of Practice BS 5390: 1999, *Site Investigations*, BSI, London.
- British Standards Institution, BS 5588 Part 5: 2004 *Fire precautions in the design, construction and use of buildings Part 5: Access and facilities for fire fighting*. BSI, London.
- British Standards Institution 1999, BS 5588 Part 8:1999, *Fire precautions in the design and use of buildings. Code of Practice for means of escape for disabled people*. BSI, London.
- British Standards Institution, BS 5588 Part 12 2004, *Fire precautions in the design, construction and use of buildings Part 12 – Managing fire safety*. BSI, London.
- British Standards Institution, BS 5839-1 2002, *Fire detection and fire alarm systems for buildings. Part 1: Code of practice for system design, installation, commissioning and maintenance*, BSI, London.
- British Standards Institution BS 5839-6: 2002 *Fire detection and alarm systems for buildings. Part 6: Code of Practice for the design, installation and servicing of fire detection and alarm systems in dwellings*. BSI, London.
- British Standards Institution, BS 6399, Part 1, 1996, *Loading for buildings. Code of Practice for dead and imposed loads*. BSI, London.
- British Standards Institution, BS 7386: 1997, *Specification for draughtstrips for the draught control of existing doors and windows in housing (including test methods)*, BSI, London.
- British Standards Institution, BS 7974: 2002, *Application of fire safety engineering principles to the design of buildings*, BSI, London.



- British Standards Institution, BS 8213, Part 1: 1991, *Windows, doors and rooflights, Code of Practice for safety in use and during the cleaning of windows and doors*. BSI, London.
- British Standards Institution, Code of Practice BS 8300: 2001, *Design of buildings and their approaches to meet the needs of disabled people*, BSI, London.
- British Standards Institution BS 9251:2005 *Code of practice for sprinkler systems for residential and domestic occupancies*. BSI London.
- British Standards Institution BS DD 9999: 2005, *Code of Practice for fire safety in the design, construction and use of buildings*. BSI, London.
- British Standards Institution, Code of Practice BS 10175:2001, *Investigation of potentially contaminated sites*. (supersedes DD 175: 1988), BSI, London.
- British Standards Institution BS EN 1284-5: 2005 *Fixed firefighting systems – Automatic sprinkler systems – Design, installation and maintenance*. BSI, London.
- The Building Disaster Assessment Group 2004, *Key Research Findings*, Office of the Deputy Prime Minister.
- CADW Welsh Historic Monuments 2002, *Overcoming the Barriers: providing physical access to historic buildings*.
- CIRIA, Special Publications 101-112 (1995-97), *Remedial treatment of contaminated land*, Vols I-XII.
- CIRIA 2001, *Sustainable drainage systems: promoting good practice – a CIRIA initiative*. Web: <http://www.ciria.org.uk/suds/background.htm>
- Department for Environment, Food and Rural Affairs (DEFRA) 1999, *A Guide to Reducing Radon Levels in the Home*, Web: <http://www.defra.gov.uk/environment/radioactivity/radon/reduce.htm>
- Disability Rights Commission 2002, Code of Practice, *Rights of Access, Goods, Facilities, Services and Premises*.
- Energy Saving Trust 2002, Good Practice Guide 268, *Energy-efficient ventilation in housing*.
- Energy Saving Trust 2003, Good Practice Guide 192, *Designing energy efficient multi-residential buildings*.
- English Heritage 1996, *Office floor loading in historic buildings*, English Heritage, London.
- English Heritage and Lead Sheet Association 1997, *Lead roofs on historic buildings: An advisory note on underside corrosion*.
- Eyre. M. Shaw 1884, *Fire and Fire Brigades*. William Clowes.
- GBG (G B Geotechnics Ltd) 2001, Technical Advice Note 23, *Non-destructive investigations of standing structures*, Historic Scotland, Edinburgh.
- Home Office (Fire Department) 2001, *Fire Service Manual Vol 1: Fire Service Technology, Equipment & Media – Hydraulics, Pumps & Water Supplies*.
- Jester, Thomas C and Park, Sharon C, Preservation Briefs 32: *Making historic properties accessible*, U.S. General Services Administration, Historic Preservation Technical Procedures.
- Kidd, Stewart 2005, Technical Advice Note 28, *Fire Safety Management in Historic Buildings*, Historic Scotland, Edinburgh.
- Newsom, Steven 2002, Guide for Practitioners 3, *Conservation of timber sash and case windows*, Historic Scotland, Edinburgh.
- Price, Sam and Rogers, Helen 2005, *Stone cantilevered staircases*, The Structural Engineer, 2936, 18 January 2005.
- Scottish Executive 2000, Planning Advice Note PAN 33, *Development of contaminated land*.
- Smith, S Wood, J and Mackenzie, R 2005, Report: *Improving sound insulation in dwellings*, Building Performance Centre, Napier University for Scottish Executive, Communities Scotland and Historic Scotland.
- Stirling, Charles 2002, *Thermal insulation: avoiding risks, A good practice guide supporting building regulation requirements*, BRE Scotland, Construction Research Communications, London.
- TRADA, 2005, Wood information, Sheet 32, *Fire resisting doorsets by upgrading*. TRADA Technology Ltd.
- Young, Victoria and Urquhart, Dennis 1996, Technical Advice Note 7, *Access to the Built Heritage*, Historic Scotland, Edinburgh.

## **HISTORIC SCOTLAND TECHNICAL ADVICE NOTES**

- 1 Preparation and Use of Lime Mortars (revised 2003)
- 2 Conservation of Plasterwork (revised 2002)
- 3 Performance Standards for Timber Sash and Case Windows (1994) (Deleted)
- 4 Thatch & Thatching Techniques (1996)
- 5 The Hebridean Blackhouse (1996)
- 6 Earth Structures and Construction in Scotland (1996)
- 7 Access to the Built Heritage (1996)
- 8 Historic Scotland Guide to International Conservation Charters (1997)
- 9 Stonecleaning of Granite Buildings (1997)
- 10 Biological Growths on Sandstone Buildings (1997)
- 11 Fire Protection Measures in Scottish Historic Buildings (1997)
- 12 Quarries of Scotland (1997)
- 13 The Archaeology of Scottish Thatch (1998)
- 14 The Installation of Sprinkler Systems in Historic Buildings (1998)
- 15 External Lime Coatings on Traditional Buildings (2001)
- 16 Burrowing Animals and Archaeology (1999)
- 17 Bracken and Archaeology (1999)
- 18 The Treatment of Graffiti on Historic Surfaces (1999)
- 19 Scottish Aggregates for Building Conservation (1999)
- 20 Corrosion in Masonry Clad Early 20th Century Steel Framed Buildings (2000)
- 21 Scottish Slate Quarries (2000)
- 22 Fire Risk Management in Heritage Buildings (2001)
- 23 Non-Destructive Investigation of Standing Structures (2001)
- 24 The Environmental Control of Dry Rot (2002)
- 25 Maintenance and Repair of Cleaned Stone Buildings (2003)
- 26 Care and Conservation of 17th Century Plasterwork in Scotland (2004)
- 27 Development and Archaeology in Historic Towns and Cities (2004)
- 28 Fire Safety Management in Heritage Buildings (2005)
- 29 Corrugated Iron and other Ferrous Cladding (2005)
- 30 Scottish Turf Construction (2006)

## **GUIDES FOR PRACTITIONERS**

- Stonecleaning – A Guide for Practitioners (1994)
- Timber Decay in Buildings – The Conservation Approach to Treatment (1999)
- 1 Rural Buildings of the Lothians: Conservation and Conversion (1999)
  - 2 Conservation of Historic Graveyards (2001)
  - 3 Conservation of Timber Sash and Case Windows (2002)
  - 4 Measured Survey and Building Recording (2003)
  - 5 Scottish Iron Structures (2005)

Available from:

Publications Department  
Technical Conservation, Research and Education Group  
Historic Scotland Conservation Bureau  
Longmore House, Salisbury Place  
EDINBURGH EH9 1SH  
Tel 0131 668 8638  
Fax 0131 668 8669  
email [hs.conservation.bureau@scotland.gov.uk](mailto:hs.conservation.bureau@scotland.gov.uk)